

TIMKEN

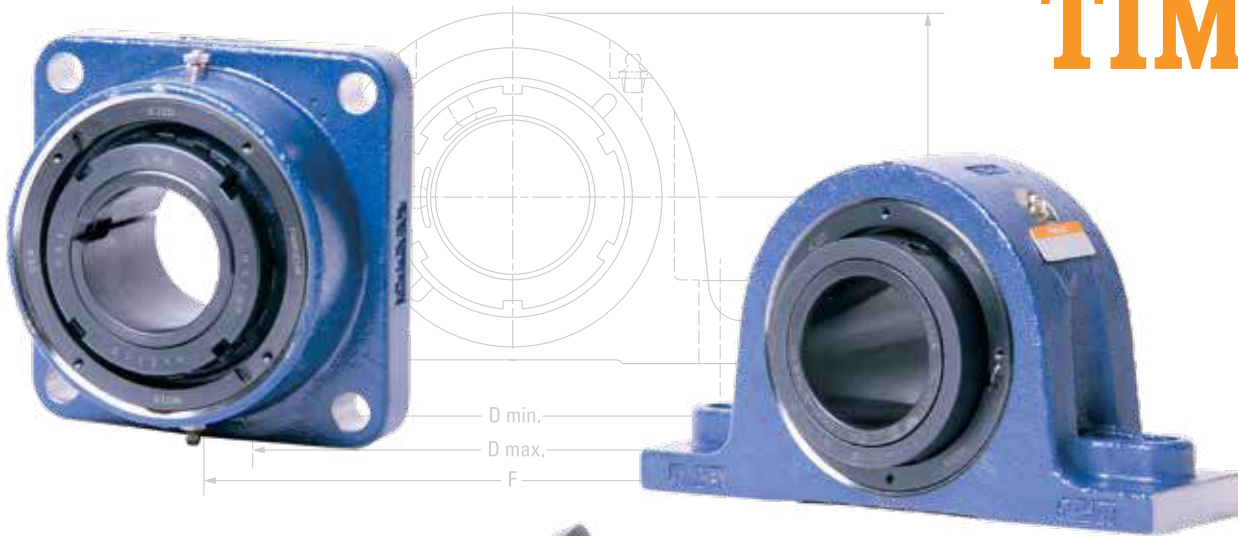

TIMKEN® SPHERICAL ROLLER BEARING SOLID-BLOCK HOUSED UNIT CATALOG

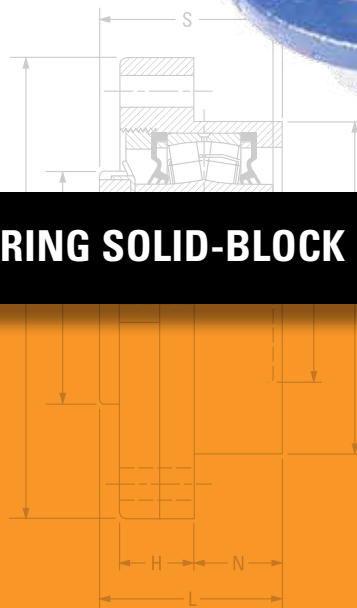
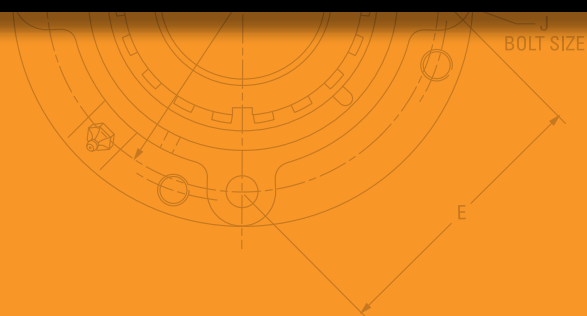

ABOUT THE TIMKEN COMPANY

As a global leader in bearings and power transmission systems, Timken focuses on precise solution design, materials and craftsmanship to deliver reliable and efficient performance that improves productivity and uptime. Timken offers a full range of bearings, belts, chains, couplings, gears and lubricants, along with rebuild and repair services.

Timken (NYSE; TKR; www.timken.com) applies its proven expertise in metallurgy, tribology and mechanical power transmission to create innovative approaches to customers' complex needs. Global availability of products and engineering talent, combined with exceptional service delivery across markets, makes Timken a preferred choice worldwide.

To view more Timken catalogs, go to www.timken.com/catalogs for interactive versions, or to download our catalog app to your smartphone or mobile device.



TIMKEN® SPHERICAL ROLLER BEARING SOLID-BLOCK HOUSED UNIT CATALOG INDEX

INTRODUCTION	2
HOW TO USE THIS CATALOG.....	6
SHELF LIFE/ STORAGE.....	7
WARNINGS.....	8

ENGINEERING

Nomenclature.....	10
Locking Styles	16
Seal and Cover Options	17
Bearing Loads	34
Normal Speed Ratings for Seals	56
Internal Radial Clearances	62
Shafting.....	65
Lubrication	67
Misalignment	67
Installation Guides	68

SPHERICAL ROLLER BEARING SOLID-BLOCK HOUSED UNITS

V-Lock® Series (double taper lock)	89
CL Series (concentric [set screw] lock)	117
EC Series (eccentric lock)	149
TA/DV TAA/DAA Series (tapered adapter lock)	175
Take-Up Frames.....	209

Index	212
-------------	-----

INTRODUCTION

When your equipment faces harsh environments, you need roller bearing housed units that are rugged enough to withstand tough conditions and deliver exceptional performance.

You gain both with Timken® spherical roller bearing solid-block housed units.

Designed specifically to perform under extreme conditions, Timken solid-block housed units are able to accept a total of 1.5 degrees misalignment and withstand the impact of falling debris. Additional misalignment can be accommodated for applications with lighter loads, contact your Timken engineer for details. Made of cast-steel housings and Timken double-row spherical roller bearings, their unique sealing design offers protection from contaminants.

Increased performance and durability help decrease the overall cost of ownership.

CUSTOMIZABLE DESIGN FEATURES TO FIT YOUR EQUIPMENT

With a full line of precision-made shaft-locking styles, seals and housings, it's easy to find the right housed unit to fit your application. Timken spherical roller bearing solid-block housed units interchange with a wide range of mounted roller bearings. Choose from many primary and secondary sealing mechanisms, and you decide how it's built without paying custom charges.

HOUSING STYLES

- Two-bolt pillow blocks
- Four-bolt pillow blocks
- Flange blocks
- Piloted flanges
- Take-up blocks
- Cartridge units
- Hanger blocks

LOCKING STYLES

- Eccentric lock
- Concentric lock (set screw) – single or double collar
- Tapered adapter lock – single or double nut
- V-Lock® double tapered lock – single or double nut

SEALS

- Labyrinth seals – DuPont™ Teflon®:
 - High-speed applications
 - Superior in dirty and wet conditions
 - Able to operate at high temperatures
 - Resistant to most chemicals
 - Abrasion-resistant
- Triple-lip seals – nitrile:
 - Self-purging
 - Excellent in dirty and wet applications
 - Chemical- and corrosion-resistant
- Triple-lip seals – urethane:
 - All the benefits of nitrile, plus resistance to abrasion

SECONDARY SEALS

- Closed-end covers
- Open-end covers with:
 - Triple-lip seal
 - DuPont Teflon
 - V-ring seal
- Piloted-flange cartridge backing plates with:
 - Triple-lip seal
- Flange block backing plates with V-ring seal or Teflon seal

HOUSING COATINGS

- Powder coating – standard
- Nickel plating – optional
- Fluoropolymer coating – optional



Fig. 1. Two-bolt pillow block.



Fig. 2. Four-bolt pillow block.

OUTLASTING THE COMPETITION

Timken solid-block housed units last a long time, yet you don't pay extra for reliability. Experience an increase in performance and durability and a decrease in your overall cost of ownership when you use a Timken solid-block housed unit.

STANDS UP TO HARSH CONDITIONS

Protects Bearing. Harsh operating environments and lubrication issues often lead to housed unit bearing damage. Timken solid-block housed units multiply protection with primary and secondary seal options, as well as steel covers in sizes to fit these units. The space between the primary and secondary seals offers a fillable grease cavity for more protection.

Handles Misalignment. Without a properly aligned shaft, the life expectancy of most housed units decreases. However, Timken spherical roller bearing solid-block housed units accept a total of 1.5 degrees of misalignment, thanks to their unique design and Timken spherical roller bearings. Additional misalignment can be accommodated for applications with lighter loads, contact your Timken engineer for details.

INDUSTRIES AND APPLICATIONS

- Metal mills
- Aggregate and cement
- Mining
- Power generation
- Sawmills and other forest process industries
- Pulp and paper
- Material conveying
- Commercial and industrial building equipment
- Sugar mills
- Agriculture
- Waste management and water treatment
- Off-highway and construction vehicles
- HVAC, fans and blowers
- Cranes, lifts and hoists

DEPENDABLE SERVICE

Every Timken spherical roller bearing solid-block housed unit is backed by the service of our industry-leading experts who are ready to assist you with product design, application knowledge and field engineering support – anything you need to help improve uptime and maximize equipment performance.



Fig. 3. Flange block.



Fig. 4. Take-up block.



Fig. 5. Piloted-flange cartridge.



Fig. 6. Cartridge block.

SOLID-BLOCK HOUSED UNIT BENEFITS

Depending on how you configure your bearing for a specific application, there's a wide range of product benefits.

- Multiple available sizes accommodate shaft diameters from 35 mm to 380 mm (1 7/16 in. to 15 in.).
- Efficient built-to-order manufacturing. Quick delivery of customized configurations for specific applications.
- Quicker installation. Machined feet, tapped puller holes, black oxide inner rings and multiple shaft-locking choices make it simpler to install this heavy-duty unit.
- Improved performance in high-contaminant environments. Wide selection of primary and secondary seals, as well as auxiliary covers.
- Bidirectional shaft expansion. Double-nut housing feature allows expansion in both directions.
- Increased uptime. Robust steel housing, a wide variety of seal choices and a high-performance Timken spherical roller bearing result in increased unit uptime.
- Increased shaft holding power and reduced shaft damage. Eccentric lock series is designed to stay tight in reversing applications on precision-ground shafts.
- Fewer misalignment issues. Bearings accept up to 1.5 degrees of misalignment.
- Protection against over-lubrication. Pressure relief valves come standard when unit is ordered with non-purgeable seals.
- Dimensionally interchanges with a wide range of other mounted roller bearing units.
- One-time shaft alignment on all housing unit styles. Machined feet ends allow for precise installation and blocking for faster future unit replacement.
- Easier removal with standard withdrawal holes on all piloted-flange units.
- Faster and easier changeover thanks to a comprehensive product offering that interchanges with virtually all solid-block roller bearing units.

SOLID-BLOCK HOUSED UNIT DESIGN

Flexibility through interchangeable components.

Double-row spherical roller bearing accepts misalignment

Black oxide inner ring reduces shaft fretting corrosion

Six primary seals in any combination:

- T seal standard labyrinth (DuPont Teflon)
- M seal standard lip (nitrile rubber)
- N seal optional (Viton™)
- O seal optional (urethane)
- B seal optional (nitrile rubber)
- C seal optional (Viton)

Housing fit: J7, size-for-size to light interference

Standard relief valve

Optional bolt-on open and closed steel or urethane secondary seals

Lubricated with premium industrial grease

Shaft-locking styles:

- Set screw
- Eccentric
- Tapered adapter
- V-Lock double tapered lock

Machined feet aid in rapid installation and alignment

Easily converted to fixed or expansion in the field

Housing can be supplied with powder coating (standard), nickel plating or fluoropolymer coatings

Housing manufactured from 75000 psi tensile cast steel that retains the bearing-to-housing fit for those rough applications

Fig. 7. High performance plus superior ruggedness.

HOW TO USE THIS CATALOG

We designed this catalog to help you find the Timken spherical roller bearing solid-block housed units best suited to your specifications.

Timken offers an extensive range of bearings and accessories in both imperial and metric sizes. For your convenience, size ranges are indicated in millimeters and inches. Contact your Timken engineer to learn more about our complete line for the special needs of your application.

This publication contains dimensions, tolerances and load ratings, as well as engineering sections describing fitting practices for shafts and housings, internal clearances, materials and other bearing features. It provides valuable assistance in the initial consideration of the type and characteristics of the bearings that may best suit your particular needs.

ISO and ANSI/ABMA, as used in this publication, refer to the International Organization for Standardization and the American National Standards Institute/American Bearing Manufacturers Association.



SHELF LIFE AND STORAGE OF GREASE-LUBRICATED BEARINGS AND COMPONENTS

To help you get the most value from our products, Timken provides guidelines for the shelf life of grease-lubricated ball and roller bearings, components and assemblies. Shelf life information is based on Timken and industry test data and experience.

SHELF LIFE

Shelf life should be distinguished from lubricated bearing/component design life as follows:

Shelf life of the grease-lubricated bearing/component represents the period of time prior to use or installation.

The shelf life is a portion of the anticipated aggregate design life. It is impossible to accurately predict design life due to variations in lubricant bleed rates, oil migration, operating conditions, installation conditions, temperature, humidity and extended storage.

TIMKEN IS NOT RESPONSIBLE FOR THE SHELF LIFE OF ANY BEARING/COMPONENT LUBRICATED BY ANOTHER PARTY.

European REACH compliance

Timken lubricants, greases and similar products sold in standalone containers or delivery systems are subject to the European REACH (Registration, Evaluation, Authorization and Restriction of CHemicals) directive. For import into the European Union, Timken can sell and provide only those lubricants and greases that are registered with ECHA (European CHemical Agency). For further information, please contact your Timken engineer.

STORAGE

Timken suggests the following storage guidelines for our finished products (bearings, components and assemblies, referred to as "products"):

- Unless directed otherwise by Timken, products should be kept in their original packaging until they are ready to be placed into service.
- Do not remove or alter any labels or stencil markings on the packaging.
- Products should be stored in such a way that the packaging is not pierced, crushed or otherwise damaged.
- After a product is removed from its packaging, it should be placed into service as soon as possible.
- When removing a product that is not individually packaged from a bulk pack container, the container should be resealed immediately after the product is removed.
- The storage area temperature should be maintained between 0° C and 40° C; temperature fluctuations should be minimized.
- The relative humidity should be maintained below 60 percent and the surfaces should be dry.
- The storage area should be kept free from airborne contaminants such as, but not limited to, dust, dirt, harmful vapors, etc.
- The storage area should be isolated from undue vibration.
- Extreme conditions of any kind should be avoided.

Due to the fact that Timken is not familiar with your particular storage conditions, we strongly suggest following these guidelines. However, you may be required by circumstances or applicable government requirements to adhere to stricter storage requirements.

Most bearing components typically ship protected with a corrosion-preventive compound that is not a lubricant. These components may be used in oil-lubricated applications without removal of the corrosion-preventive compound. When using some specialized grease lubrications, we advise you to remove the corrosion-preventive compound before packing the bearing components with suitable grease.

Be careful in selecting lubrication, however, since different lubricants are often incompatible.

When you receive a bearing shipment, do not remove products from their packaging until they are ready for mounting so they do not become corroded or contaminated.

Store bearings and bearing housings in an appropriate atmosphere so they remain protected for the intended period.

WARNINGS



WARNING

Failure to observe the following warnings could create a risk of death or serious injury.

Proper maintenance and handling practices are critical. Always follow installation instructions and maintain proper lubrication.

Overheated bearings can ignite explosive atmospheres. Special care must be taken to properly select, install, maintain and lubricate housed unit bearings that are used in or near atmospheres that may contain explosive levels of combustible gases or accumulations of dust such as grain, coal, or other combustible materials. Consult your equipment designer or supplier for installation and maintenance instructions.

If hammer and bar are used for installation or removal of a part, use a mild steel bar (e.g., 1010 or 1020 grade). Mild steel bars are less likely to cause release of high speed fragments from the hammer or bar or the part being installed or removed.



CAUTION

Failure to follow these cautions may result in property damage.

Do not use damaged housed units.

Warnings for this product line are in this catalog and posted on www.timken.com/en-us/products/warnings

NOTE

Do not use excessive force when mounting or dismantling the unit.

Follow all tolerance, fit, and torque recommendations.

Always follow the Original Equipment Manufacturer's installation and maintenance guidelines.

Ensure proper alignment.

Never weld housed units.

Do not heat components with an open flame.

Do not operate at bearing temperatures above 250° F (121° C).

When converting a solid-block housed unit bearing from fixed to expansion, it is imperative that the unit that is going to be converted is correctly oriented. Since the insert in a steel housed unit flange bearing is held against either a shoulder or snap ring

opposite the housing retaining nut, a flange bearing that has been converted to expansion can only float in the direction of the retaining nut. Based on this, the retaining nut must be on the side of the housing opposite the fixed bearing.

When converting a solid-block housed unit from expansion to fixed on a mounted bearing, the locking-collar set screws must be released to allow the insert to move both in the housing and on the shaft.

DISCLAIMER

This catalog is provided solely to give you analysis tools and data to assist you in your product selection. Product performance is affected by many factors beyond the control of Timken. Therefore, the suitability and feasibility of all product selection must be validated by you.

Timken products are sold subject to our terms and conditions of sale, which include its limited warranty and remedy, which terms may be found at <https://www.timken.com/legal-notice/termsandconditionsofsale/>

Please consult with your Timken engineer for more information and assistance.

Every reasonable effort has been made to ensure the accuracy of the information in this writing, but no liability is accepted for errors, omissions or for any other reason.

COMPLIANCE

To view the complete engineering catalog, please visit www.timken.com. To order the catalog, please contact your Timken sales engineer and request a copy of the Timken Engineering Manual (order number 10424).

The Timken Company products shown in this catalog may be directly, or indirectly subject to a number of regulatory standards and directives originating from authorities in the USA, European Union, and around the world, including: REACH (EC 1907/2006, RoHS (2011/65/EU), ATEX (94/9/EC), 'CE' MARKING (93/68/EEC), CONFLICT MINERALS (Section 1502 of the Dodd-Frank Wall Street Reform and Consumer Protection Act).

For any questions or concerns regarding whether Timken products comply with these, or other regulatory standards or directives, please contact your Timken engineer or customer services representative.

Updates are made periodically to this catalog. Visit www.timken.com for the most recent version of the Timken Spherical Roller Bearing Solid-Block Housed Unit Catalog.



ENGINEERING

The following topics are covered within this section:

Nomenclature.....	10
Locking Styles.....	16
Seal and Cover Options.....	17
Bearing Loads.....	34
Normal Speed Ratings for Seals.....	56
Internal Radial Clearances.....	62
Shafting.....	65
Lubrication.....	67
Misalignment.....	67
Installation Guides.....	68



To view more Timken catalogs, go to www.timken.com/catalogs for interactive versions, or to download the Timken catalog app for your smartphone or mobile device scan the QR code or go to timkencatalogs.com.

NOMENCLATURE **ORDERING SOLID-BLOCK HOUSED UNITS**

Every solid-block housed unit is made of cast steel for greater strength (compared to cast iron). All bearings feature a double-row, spherical roller bearing design for a high load-carrying capacity, misalignment tolerance and reduced friction.

Starting with these standard design advantages, you can choose from a wide range of sizes, locking styles, seal options and housing styles suited precisely for your application.

There are many ways to determine the correct solid-block housed unit part number for ordering purposes:

- Once you determine the best locking style, housing and seal options for your application, you can easily find the correct part number in the tables included in the following sections.
- If you are ordering a replacement for an existing housed unit, locate the part number for that housed unit on the housing tag.
- If none of the above apply, or if you have additional questions or concerns about ordering the correct housed unit, contact your Timken engineer.



SPHERICAL ROLLER BEARING SOLID-BLOCK HOUSED UNIT

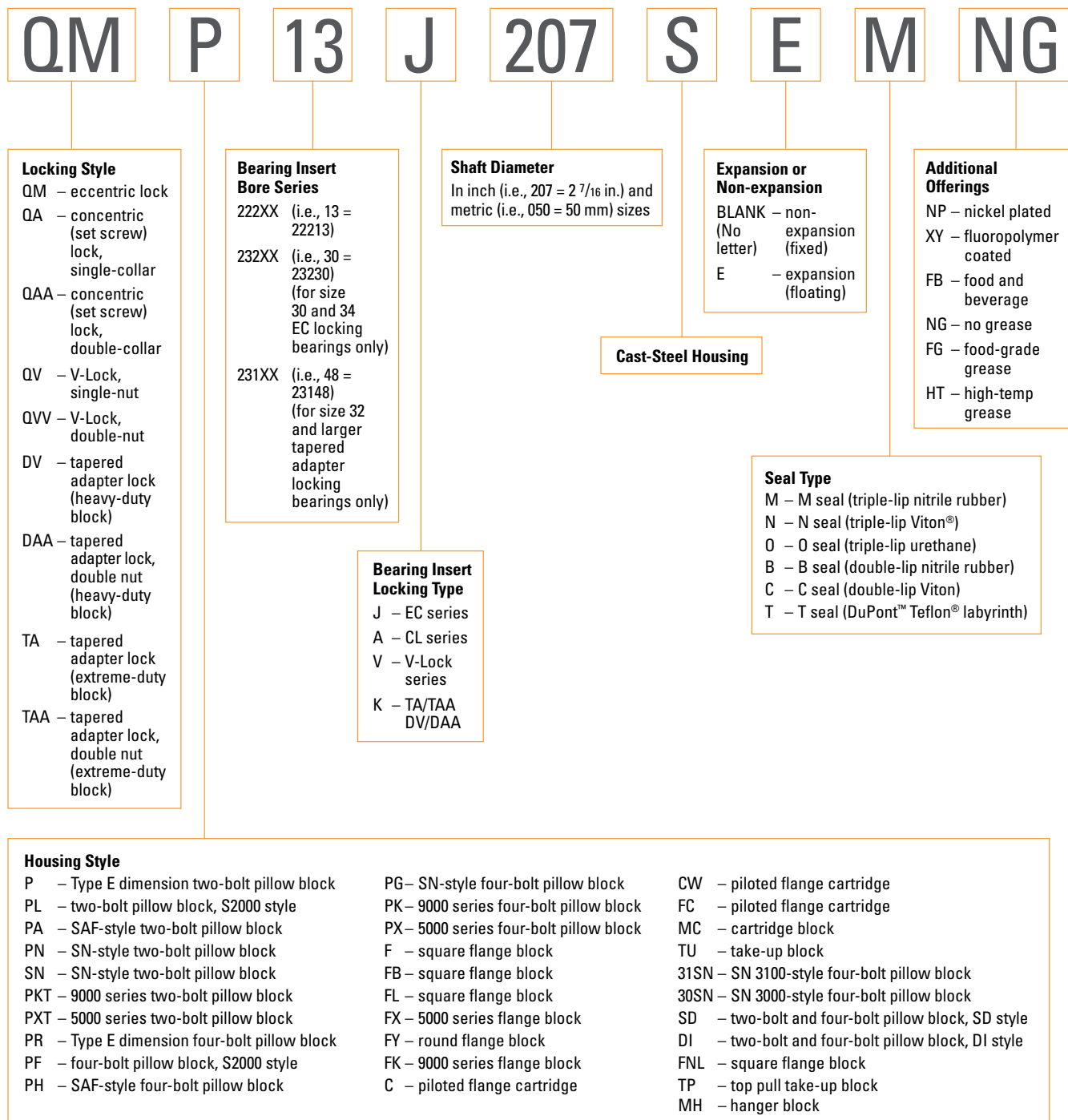

STEEL COVER

OPEN-END STEEL COVER

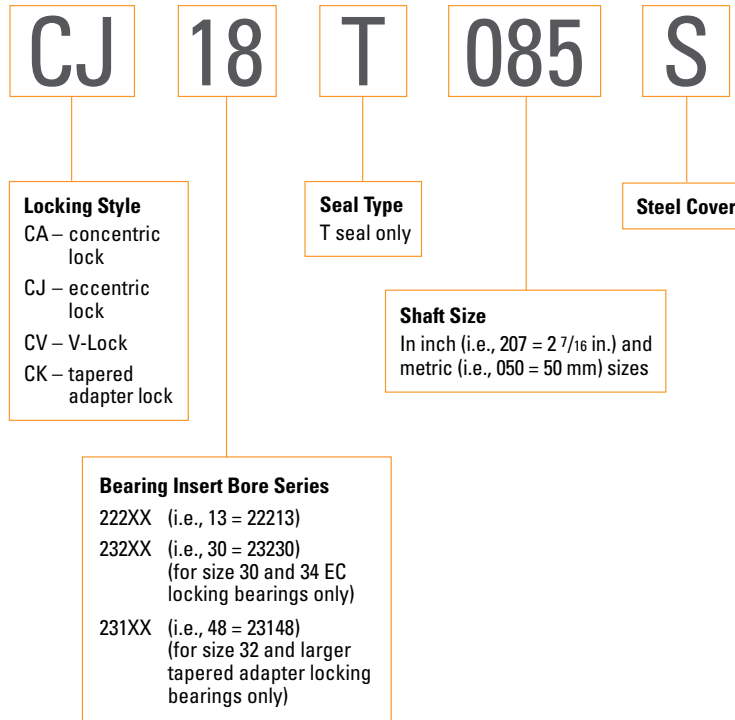

STEEL COVER

CLOSED-END STEEL COVER

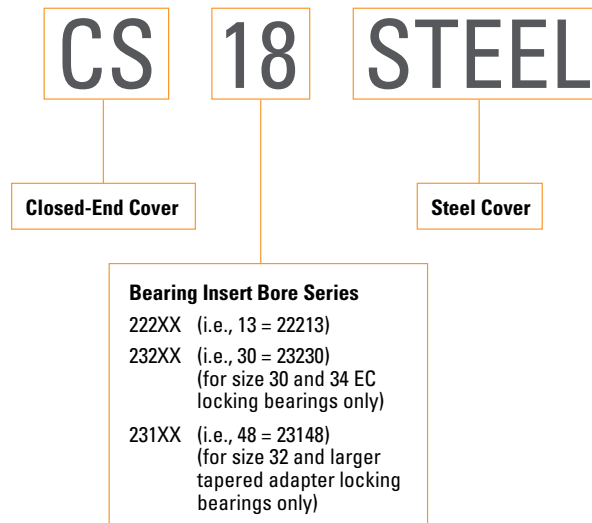

URETHANE COVER

OPEN-END COVER WITH DR SEAL

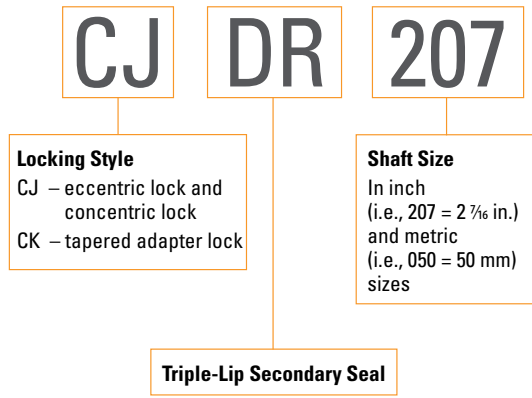

V-LOCK OPEN-END COVER WITH DR SEAL

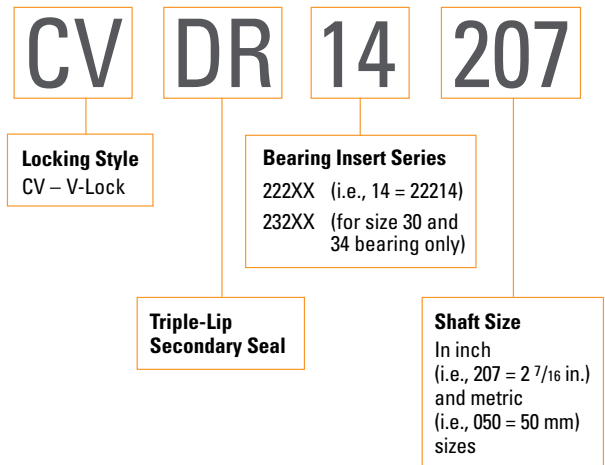

OPEN-END COVER WITH VR SEAL

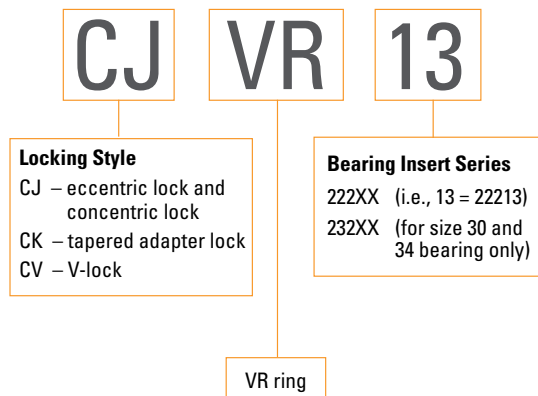

CLOSED-END COVER

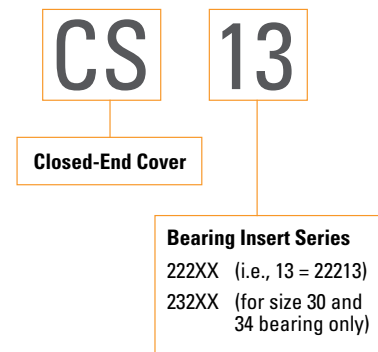

BACKING PLATE

CL AND EC SERIES BEARINGS

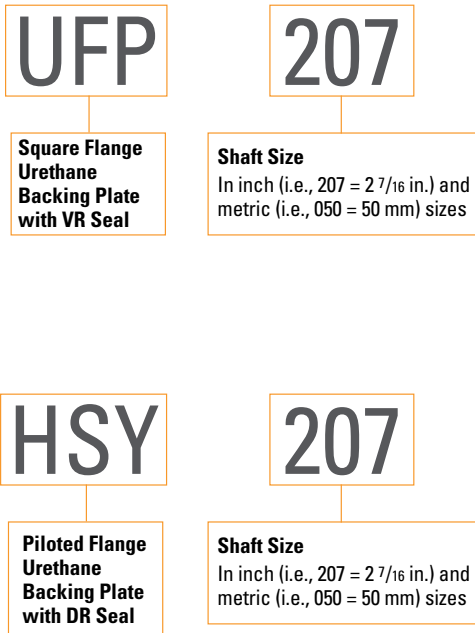

HIGH-PERFORMANCE STEEL BACKING PLATE

CL and EC series bearings

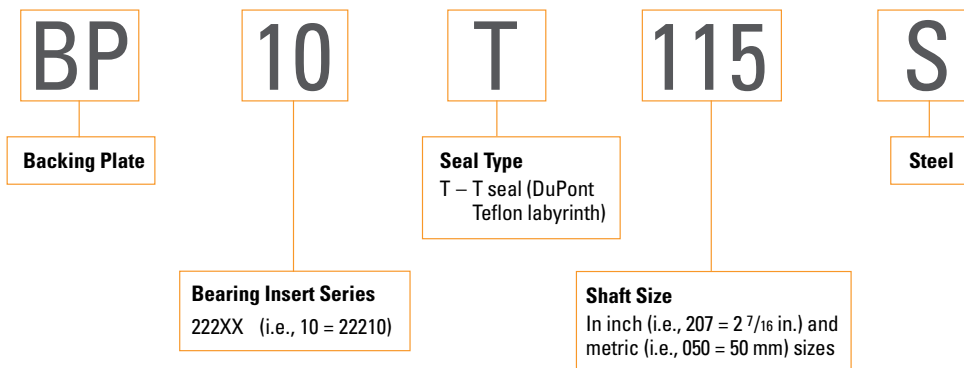

COMPARISON CHART

TABLE 1. COMPARISON CHART

	Housing Type	Primary Seals						Secondary Seals and Covers					
		M	N	O	B	C	T	Open-End Cover			Closed-End Cover	HSY Flange Cartridge Backing Plate	UFP Backing Plate
								DR	VR	T		DR	
V-Lock (Timken Exclusive Double Taper Lock)	Pillow Block	•	•	•	•	•	•	•	•	•	•		
	Flange Block	•	•	•	•	•	•	•	•	•	•		
	Piloted Flange Cartridge	•	•	•	•	•	•	•	•	•	•		
	Take-up Block	•	•	•	•	•	•	•	•	•	•		
	Cartridge Block	•	•	•	•	•	•	•	•	•	•		
CL Series (Set Screw Lock)	Pillow Block	•	•	•	•	•	•	•	•	•	•		
	Flange Block	•	•	•	•	•	•	•	•	•	•		•
	Piloted Flange Cartridge	•	•	•	•	•	•	•	•	•	•	•	
	Take-up Block	•	•	•	•	•	•	•	•	•	•		
	Cartridge Block	•	•	•	•	•	•	•	•	•	•		
	Hanger Block	•	•	•	•	•	•	•	•	•	•		
EC Series (Eccentric Lock)	Pillow Block	•	•	•	•	•	•	•	•	•	•		
	Flange Block	•	•	•	•	•	•	•	•	•	•		•
	Piloted Flange Cartridge	•	•	•	•	•	•	•	•	•	•	•	
	Take-up Block	•	•	•	•	•	•	•	•	•	•		
	Cartridge Block	•	•	•	•	•	•	•	•	•	•		
	Hanger Block	•	•	•	•	•	•	•	•	•	•		
TA/TAA Series (Tapered Adapter Lock)	Pillow Block	•	•	•	•	•	•	•	•	•	•		
	Flange Block	•	•	•	•	•	•	•	•	•	•		
	Piloted Flange Cartridge	•	•	•	•	•	•	•	•	•	•		
	Cartridge Block	•	•	•	•	•	•	•	•	•	•		
DV/DAA Series (Tapered Adapter Lock)	Pillow Block	•	•	•	•	•	•	•	•	•	•		
	Flange Block	•	•	•	•	•	•	•	•	•	•		
	Piloted Flange Cartridge	•	•	•	•	•	•	•	•	•	•		

LOCKING STYLES

V-LOCK (DOUBLE-TAPERED LOCK) U.S. PAT. NO. 7344313

The V-Lock locking mechanism is excellent in high-speed applications and designed to maximize shaft-holding power and minimize the time needed for installation and removal as compared to conventional locking mechanisms. With no need for feeler gages during installation, the V-Lock locking mechanism offers superior holding power and is designed to eliminate overtightening. Mechanical withdrawal is a feature of double-nut units.

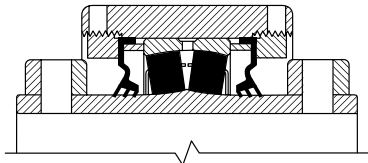

Fig. 8. V-Lock double tapered lock.

CONCENTRIC LOCK (SET SCREW) – CL SERIES

Two set screws positioned at 60 degrees provide aggressive holding power. When configured with a double-collared insert, the bearing provides double the holding power compared to our standard single-collared insert.

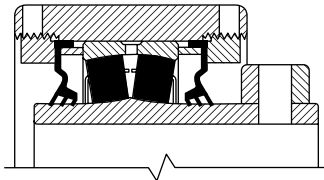

Fig. 9. Single set screw lock.

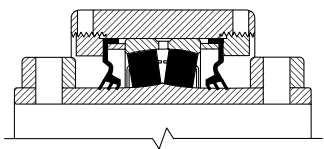

Fig. 10. Double set screw lock.

ECCENTRIC LOCK – EC SERIES

A reduced eccentric offset results in more mechanical advantage. This series provides a secure lock that should not release from a properly prepared shaft even in reversing applications.

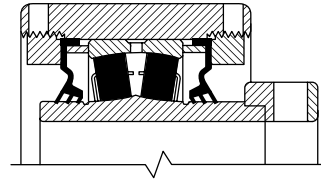

Fig. 11. Eccentric lock.

TAPERED ADAPTER LOCK – TA/TAA DV/DAA SERIES

Excellent in high-load applications, this design uses a longer 2300-series adapter for increased shaft contact. This design offers the best shaft concentricity and highest capacity all while having the ability to accommodate undersized shafting.

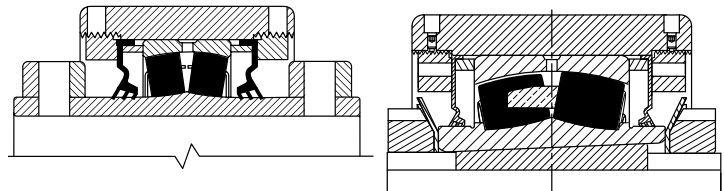

Fig. 12. Tapered adapter lock.

A simple design that in turn simplifies installation and removal of mounted bearings. The standard tapered adapter sleeve has been extended to accommodate a second nut on the back end. This nut is factory set for nominal shaft sizes and can be adjusted in the field to accommodate actual (under/over) shaft size if necessary.

HOUSING COATINGS

POWDER COATING – STANDARD

All of our steel housings come powder coated from the factory. Powder coating gives a hard finish that is tough and durable.

NICKEL PLATING – OPTIONAL

By nickel plating any of our housings, we are able to offer superior resistance to wear and corrosion.

FLUOROPOLYMER COATING – OPTIONAL

We have the ability to coat your housing with either industrial or food grade fluoropolymer for your washdown and/or food contact applications.

SEAL AND COVER OPTIONS

PRIMARY SEALS

Primary seals are installed between the inner ring of the bearing and the housing. They are held securely in place by the external housing nut. Primary seals can be contacting or non-contacting, purging or non-purging and are available in several material compounds for a variety of applications.

TRIPLE-LIP SEALS – CONTACTING, SELF-PURGING, LOW TO MODERATE SPEEDS⁽¹⁾

Timken offers three kinds of medium-contact triple-lip seals. Choose from seals made of nitrile synthetic rubber (acrylonitrile butadiene), Viton™ fluoroelastomer or urethane.

- **M Seal** – This seal, made of nitrile rubber, offers superior sealing in moist and dirty applications. It is chemical- and corrosion-resistant and provides excellent lubrication retention. It also allows excess grease to purge from the bearing cavity.
- **N Seal** – Made of Viton, this seal provides excellent chemical resistance and can operate at higher temperatures than nitrile rubber.
- **O Seal** – This seal, made of high-strength urethane for superior abrasion resistance.

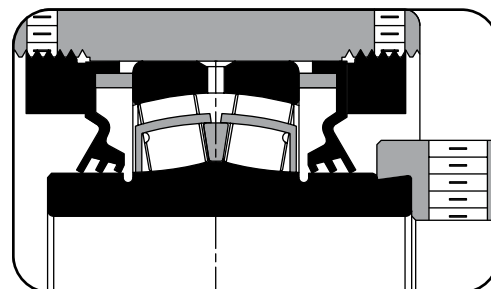

Fig. 13. Triple-lip seals.

LABYRINTH SEALS – NON-CONTACTING, NON-PURGING, ALL SPEEDS⁽²⁾

Instead of trying to form a seal with a single strong barrier, a labyrinth seal uses a winding passageway to accomplish the same reduction in flow. Not only is seal friction reduced, but so is seal wear.

- **T Seal** – This seal consists of a DuPont™ Teflon® ring pressed onto the inner ring of the bearing that floats between two pieces of formed steel to accommodate misalignment. When using this seal, the housing comes with a vent fitting. Developed for higher-speed applications involving dirty conditions or moisture-affected areas, it is able to operate at higher temperatures and is impervious to most chemicals.

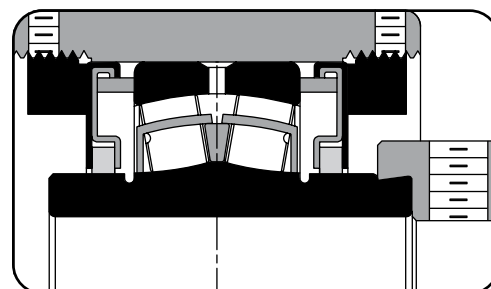

Fig. 14. T seal.

DOUBLE-LIP SEALS – CONTACTING, NON-PURGING, LOW SPEEDS⁽¹⁾⁽²⁾

These seals incorporate a double-lip seal, a garter spring for maximum contact, and a heavy-duty steel shield that protects the seal from large pieces of debris that could damage the seal itself.

- **B Seal** – Made of nitrile rubber, this seal offers superior protection in applications with oil lubrication and is designed for extreme moisture, fine dust or extremely dirty applications. When using this seal, the housing comes with a vent fitting.
- **C Seal** – Made of Viton, this seal provides excellent chemical and abrasion resistance and can operate at higher temperatures than nitrile rubber. When using this seal, the housing comes with a vent fitting.

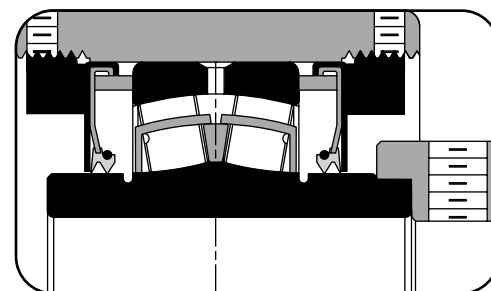

Fig. 15. Double-lip seals.

⁽¹⁾Temperature limit -40° C to 121° C (-40° F to 250° F) continuous, 149° C (300° F) intermittent. Constant seal-lip pressure on the inner ring results in higher operating temperatures of the complete unit. (See pages 56 – 58).

⁽²⁾Relief valve is standard.

SECONDARY SEALS

In many circumstances, bearings become damaged in housed units due to premature primary seal wear. This is usually the result of harsh operating environments or lubrication issues. Timken offers secondary sealing options that provide an additional barrier to protect the primary seal. These economical secondary seals and covers are easily outfitted on virtually all solid-block housed units.

STEEL COVERS

Labyrinth Seals – Non-Contacting, Non-Purging, All Speeds

A labyrinth seal uses a winding passageway to accomplish a reduction in flow instead of trying to form a seal with a single strong barrier. Seal friction and wear is reduced.

- T Seal** – This seal, which is used in the open-end steel covers, consists of a DuPont Teflon ring pressed onto the shaft that floats between two pieces of formed steel to accommodate misalignment. Developed for higher-speed applications involving dirty conditions or moisture-affected areas, it is able to operate at higher temperatures and is impervious to most chemicals, while avoiding shaft damage.

URETHANE COVERS

DR Triple-Lip Secondary Seal – Low Speeds

The DR seal is the standard triple-lip seal adapted for use on the open-end covers and piloted flange cartridge backing plates (HSY). This seal can move within the cover or backing plate opening to accommodate misalignment while maintaining full contact to the shaft for positive sealing.

VR Viton Ring Secondary Seal – High Speeds

The VR seal, made of nitrile rubber, rides on the shaft and seals against the open-end covers and flange block backing plates (UFP).

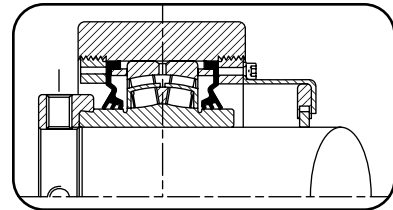

Fig. 16. Open-end steel cover with T seal.

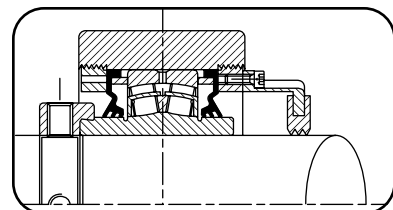

Fig. 17. Open-end urethane cover with DR seal.

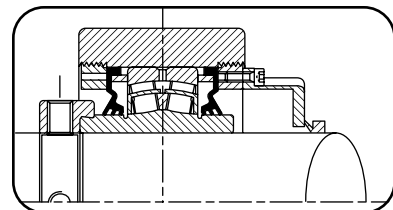

Fig. 18. Open-end urethane cover with VR seal.

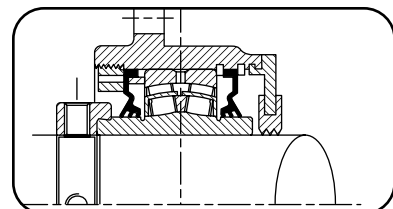

Fig. 19. HSY backing plate with DR seal.

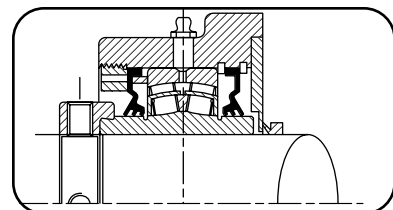

Fig. 20. UFP backing plate with VR seal.

STEEL AUXILIARY COVERS

Steel auxiliary covers bolt directly onto spherical roller bearing solid-block housed units. A DuPont Teflon labyrinth seal on the open-ended covers guards against shaft damage and gives protection at high running speeds. Made from steel to withstand the toughest applications, the covers are black-oxide treated for improved corrosion protection.

These covers are available in both open-ended and closed-ended designs for standard and custom configurations of Timken spherical roller bearing solid-block housed units.

Closed-End Covers (CS)

These bolt-on covers are designed to be virtually indestructible and extremely convenient. They are made from structural steel or urethane and are easy to install. The cover completely seals the bearing, preventing contamination from reaching the primary seal. Every cover is outfitted with a grease fitting to fill the cover cavity for an added barrier against contamination.



Fig. 21. Closed-end covers.

Open-End Covers (CJ/CK/CV)

These bolt-on covers are made from structural steel or urethane for repeated and continuous use. The covers are used with either a DuPont Teflon (T seal), triple-lip seal (DR) or a V-ring seal (VR) to help prevent contamination from reaching the primary seal. Every cover is outfitted with a grease fitting to fill the cover cavity for an added barrier against contamination.



Fig. 22. Open-end covers.

PILOTED FLANGE CARTRIDGE BACKING PLATES (HSY)

The HSY backing plate is designed to work in conjunction with the piloted flange cartridge housed units. Made of structural urethane, these plates are fitted to the back side of the pilot for extra protection. The HSY plate comes supplied with a triple-lip seal (DR) or a contamination collar (optional) to form an additional barrier against contamination for the most demanding applications.



Fig. 23. Piloted flange cartridge backing plates.

FLANGE BLOCK BACKING PLATES (UFP)

These backing plates are made from structural urethane and are uniquely designed to work with our flange block housed units. Made to fit flush against the back of the housing, these plates create a labyrinth over the inner ring for additional contamination protection. The UFP plate, when used with an optional V-ring seal (VR), provides an extra barrier against extreme contamination.



Fig. 24. Flange block backing plates.

HIGH-PERFORMANCE STEEL BACKING PLATE (BP)

These backing plates are made from mild steel and are uniquely designed to fit with our square flange block housed units. These plates use dual Teflon seals to make 360° contact on the shaft to eliminate contamination into the flange side of the housing. The plate is placed on the shaft prior to mounting the flange block and mounts flush with the back of the housing secured by the mounting bolts.



Fig. 25. High-performance steel backing plates.

STEEL COVER DIMENSIONS

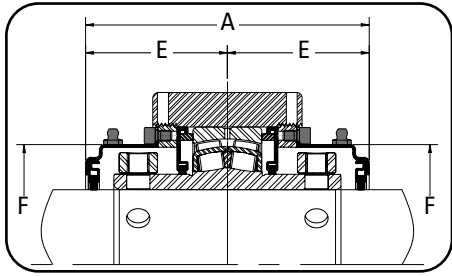

Fig. 26. Double open-end cover.⁽¹⁾

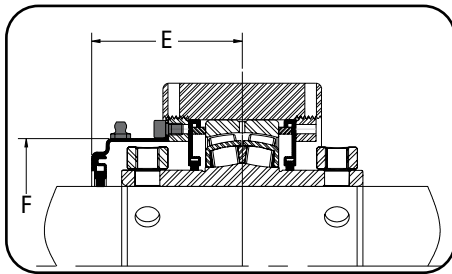

Fig. 27. Single open-end cover.

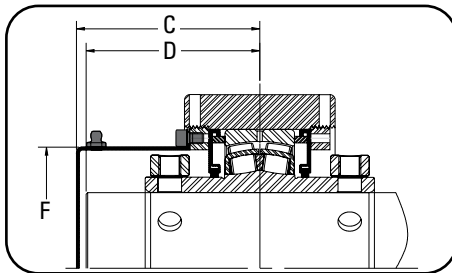

Fig. 28. Single closed-end cover.

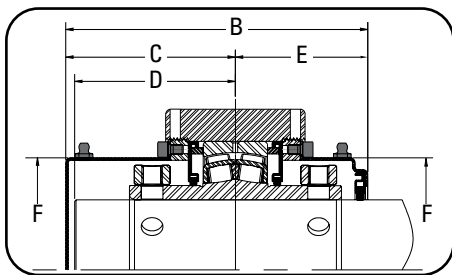

Fig. 29. Single closed-end cover and single open-end cover.⁽¹⁾

TABLE 2. V-LOCK SERIES – STRAIGHT BORE EQUIVALENTS

Cover Part No.	Shaft Dia.	Bearing No.	Steel Cover Dimensions					
			A	B	C	D	E	F
	mm in.		mm in.	mm in.	mm in.	mm in.	mm in.	mm in.
CS11STEEL	CLOSED	22211						
CV11T115S	1 15/16 in.		128.5	143.3	79.2	75.2	64.3	89.7
CV11T050S	50 mm		5.06	5.64	3.12	2.96	2.53	3.53
CV11T200S	2 in.							
CS12STEEL	CLOSED	22212						
CV12T055S	55 mm		129.0	141.5	77.0	72.9	64.5	98.6
CV12T203S	2 3/16 in.		5.08	5.57	3.03	2.87	2.54	3.88
CV12T204S	2 1/4 in.							
CS14STEEL	CLOSED	22214						
CV14T060S	60 mm		135.4	159.3	91.4	87.4	67.8	103.6
CV14T207S	2 7/16 in.		5.33	6.27	3.60	3.44	2.67	4.08
CV14T208S	2 1/2 in.							
CV14T065S	65 mm							
CS16STEEL	CLOSED	22216						
CV16T211S	2 11/16 in.		150.1	167.6	92.5	88.4	75.2	116.1
CV16T212S	2 3/4 in.		5.91	6.60	3.64	3.48	2.96	4.57
CV16T070S	70 mm							
CV16T215S	2 15/16 in.							
CV16T075S	75 mm							
CV16T300S	3 in.							
CS19STEEL	CLOSED	22219						
CV19T080S	80 mm		167.9	191.0	106.9	102.9	84.1	139.4
CV19T303S	3 3/16 in.		6.61	7.52	4.21	4.05	3.31	5.49
CV19T304S	3 1/4 in.							
CV19T085S	85 mm							
CV19T307S	3 7/16 in.							
CV19T308S	3 1/2 in.							
CV19T090S	90 mm							
CS22STEEL	CLOSED	22222						
CV22T311S	3 11/16 in.		217.7	241.8	133.1	129.0	109.0	180.1
CV22T312S	3 3/4 in.		8.57	9.52	5.24	5.08	4.29	7.09
CV22T100S	100 mm							
CV22T315S	3 15/16 in.							
CV22T400S	4 in.							
CS26STEEL	CLOSED	22226						
CV26T110S	110 mm		219.7	242.8	133.1	129.0	110.0	209.3
CV26T407S	4 7/16 in.		8.65	9.56	5.24	5.08	4.33	8.24
CV26T408S	4 1/2 in.							
CV26T115S	115 mm							
CS28STEEL	CLOSED	22228						
CV28T125S	125 mm		223.5	246.9	135.1	131.1	111.8	209.3
CV28T415S	4 15/16 in.		8.80	9.72	5.32	5.16	4.40	8.24
CV28T500S	5 in.							
CV28T130S	130 mm							

⁽¹⁾Double covers available only on pillow block and take-up style bearings.

TABLE 3. V-LOCK SERIES—TAPERED BORE EQUIVALENTS

Cover Part No.	Shaft Dia.	Bearing No.	Steel Cover Dimensions					
			A	B	C	D	E	F
	mm in.		mm in.	mm in.	mm in.	mm in.	mm in.	mm in.
CS11STEEL	CLOSED	22211						
CV11T115S	1 1/16 in.		124.2	139.2	77.0	72.9	62.2	89.7
CV11T050S	50 mm		4.89	5.48	3.03	2.87	2.45	3.53
CV11T200S	2 in.	22213						
CS13STEEL	CLOSED							
CV13T055S	55 mm		130.3	154.2	88.9	84.8	65.3	103.6
CV13T203S	2 3/16 in.		5.13	6.07	3.50	3.34	2.57	4.08
CV13T204S	2 1/4 in.	22215						
CS15STEEL	CLOSED							
CV15T060S	60 mm		142.7	160.3	88.9	84.8	71.4	116.1
CV15T207S	2 7/16 in.		5.62	6.31	3.50	3.34	2.81	4.57
CV15T208S	2 1/2 in.	22217						
CV15T065S	65 mm							
CS17STEEL	CLOSED							
CV17T211S	2 11/16 in.	22217						
CV17T212S	2 3/4 in.		133.9	156.0	88.9	84.8	67.1	132.1
CV17T070S	70 mm		5.27	6.14	3.50	3.34	2.64	5.2
CV17T215S	2 15/16 in.	22220						
CV17T075S	75 mm							
CS20STEEL	CLOSED							
CV20T080S	80 mm	22220						
CV20T303S	3 3/16 in.		170.4	193.0	108.0	103.9	85.3	160.3
CV20T304S	3 1/4 in.		6.71	7.60	4.25	4.09	3.36	6.31
CV20T085S	85 mm	22222						
CV20T307S	3 7/16 in.							
CV20T308S	3 1/2 in.							
CV20T090S	90 mm	22222						
CS22STEEL	CLOSED							
CV22T311S	3 11/16 in.		208.5	232.9	128.5	124.5	104.4	180.1
CV22T312S	3 3/4 in.		8.21	9.17	5.06	4.90	4.11	7.09
CV22T100S	100 mm	22224						
CV22T315S	3 15/16 in.		213.6	237.7	131.1	127.0	106.7	180.1
CV22T400S	4 in.		8.41	9.36	5.16	5.00	4.20	7.09
CS24STEEL	CLOSED	22226						
CV24T110S	110 mm		210.6	233.9	128.5	124.5	105.4	209.3
CS26STEEL	CLOSED		8.29	9.21	5.06	4.90	4.15	8.24
CV26T110S	110 mm	22228						
CV26T407S	4 7/16 in.		214.6	238.0	130.6	126.5	107.2	209.3
CV26T408S	4 1/2 in.		8.45	9.37	5.14	4.98	4.22	8.24
CV26T115S	115 mm	22228						
CS28STEEL	CLOSED							
CV28T125S	125 mm							
CV28T415S	4 15/16 in.	22226						
CV28T500S	5 in.		219.7	242.8	133.1	129.0	110.0	209.3
CV28T130S	130 mm		8.65	9.56	5.24	5.08	4.33	8.24

TABLE 4. CL SERIES—SINGLE AND DOUBLE SET SCREW LOCKS

Cover Part No.	Shaft Dia.	Bearing No.	Steel Cover Dimensions					
			A	B	C	D	E	F
	mm in.		mm in.	mm in.	mm in.	mm in.	mm in.	
CS08STEEL	CLOSED	22208						
CA08T035S	35 mm		115.6	127.8	69.9	65.8	57.9	69.6
CA08T107S	1 7/16 in.		4.55	5.03	2.75	2.59	2.28	2.74
CA08T108S	1 1/2 in.	22209						
CS09STEEL	CLOSED							
CA09T040S	40 mm		121.7	130.8	69.9	65.8	61.0	74.7
CA09T111S	1 11/16 in.		4.79	5.15	2.75	2.59	2.40	2.94
CA09T112S	1 3/4 in.	22210						
CA09T045S	45 mm							
CS10STEEL	CLOSED							
CA10T115S	1 15/16 in.	22210						
CA10T050S	50 mm		122.7	132.8	73.2	69.1	61.5	79.8
CA10T200S	2 in.		4.83	5.23	2.88	2.72	2.42	3.14
CS11STEEL	CLOSED	22211						
CA11T055S	55 mm		128.5	143.3	79.2	75.2	64.3	89.7
CA11T203S	2 3/16 in.		5.06	5.64	3.12	2.96	2.53	3.53
CA11T204S	2 1/4 in.	22213						
CS13STEEL	CLOSED							
CA13T060S	60 mm		135.4	159.3	91.4	87.4	67.8	103.6
CA13T207S	2 7/16 in.		5.33	6.27	3.60	3.44	2.67	4.08
CA13T208S	2 1/2 in.	22215						
CA13T065S	65 mm							
CS15STEEL	CLOSED							
CA15T211S	2 11/16 in.	22215						
CA15T212S	2 3/4 in.		148.1	165.6	91.4	87.4	74.2	116.1
CA15T070S	70 mm		5.83	6.52	3.60	3.44	2.92	4.57
CA15T215S	2 15/16 in.	22218						
CA15T075S	75 mm							
CA15T300S	3 in.							
CS18STEEL	CLOSED	22218						
CA18T080S	80 mm		164.8	188.0	105.7	101.6	82.6	139.4
CA18T303S	3 3/16 in.		6.49	7.40	4.16	4.00	3.25	5.49
CA18T304S	3 1/4 in.	22220						
CA18T085S	85 mm							
CA18T307S	3 7/16 in.							
CA18T308S	3 1/2 in.	22220						
CA18T090S	90 mm							
CS20STEEL	CLOSED							
CA20T311S	3 11/16 in.	22220						
CA20T312S	3 3/4 in.		179.6	202.2	112.5	108.5	89.9	160.3
CA20T100S	100 mm		7.07	7.96	4.43	4.27	3.54	6.31
CA20T315S	3 15/16 in.	22222						
CA20T400S	4 in.							
CS22STEEL	CLOSED							
CA22T110S	110 mm	22222						
CA22T407S	4 7/16 in.		217.7	241.8	133.1	129.0	109.0	180.1
CA22T408S	4 1/2 in.		8.57	9.52	5.24	5.08	4.29	7.09
CA22T115S	115 mm	22226						
CS26STEEL	CLOSED							
CA26T125S	125 mm		219.7	242.8	133.1	129.0	110.0	209.3
CA26T415S	4 15/16 in.		8.65	9.56	5.24	5.08	4.33	8.24
CA26T500S	5 in.	22226						
CA26T130S	130 mm							

STEEL COVER DIMENSIONS – continued

TABLE 5. EC SERIES – ECCENTRIC LOCK

Cover Part No.	Shaft Dia.	Bearing No.	Steel Cover Dimensions					
			A	B	C	D	E	F
	mm in.		mm in.	mm in.	mm in.	mm in.	mm in.	mm in.
CS08STEEL	CLOSED	22208	115.6 4.55	127.8 5.03	69.9 2.75	65.8 2.59	57.9 2.28	69.6 2.74
CJ08T035S	35 mm							
CJ08T107S	1 7/16 in.							
CJ08T108S	1 1/2 in.							
CS09STEEL	Closed	22209	121.7 4.79	130.8 5.15	69.9 2.75	65.8 2.59	61.0 2.40	74.7 2.94
CJ09T040S	40 mm							
CJ09T111S	1 11/16 in.							
CJ09T112S	1 3/4 in.							
CJ09T045S	45 mm	22210	122.7 4.83	132.8 5.23	73.2 2.88	69.1 2.72	61.5 2.42	79.8 3.14
CS10STEEL	CLOSED							
CJ10T115S	1 5/8 in.							
CJ10T050S	50 mm							
CJ10T200S	2 in.	22211	128.5 5.06	143.3 5.64	79.2 3.12	75.2 2.96	64.3 2.53	89.7 3.53
CS11STEEL	CLOSED							
CJ11T055S	55 mm							
CJ11T203S	2 3/8 in.							
CJ11T204S	2 1/4 in.	22213	135.4 5.33	159.3 6.27	91.4 3.60	87.4 3.44	67.8 2.67	103.6 4.08
CS13STEEL	CLOSED							
CJ13T060S	60 mm							
CJ13T207S	2 7/8 in.							
CJ13T208S	2 1/2 in.	22215	148.1 5.83	165.6 6.52	91.4 3.60	87.4 3.44	74.2 2.92	116.1 4.57
CJ13T065S	65 mm							
CS15STEEL	CLOSED							
CJ15T211S	2 11/16 in.							
CJ15T212S	2 3/4 in.	22218	164.8 6.49	188.0 7.40	105.7 4.16	101.6 4.00	82.6 3.25	139.4 5.49
CJ15T070S	70 mm							
CJ15T215S	2 15/16 in.							
CJ15T075S	75 mm							
CJ15T300S	3 in.	22220	179.6 7.07	202.2 7.96	112.5 4.43	108.5 4.27	89.9 3.54	160.3 6.31
CS18STEEL	CLOSED							
CJ18T080S	80 mm							
CJ18T303S	3 3/8 in.							
CJ18T304S	3 1/4 in.	22222	217.7 8.57	241.8 9.52	133.1 5.24	129.0 5.08	109.0 4.29	180.1 7.09
CJ18T085S	85 mm							
CJ18T307S	3 7/8 in.							
CJ18T308S	3 1/2 in.							
CJ18T090S	90 mm	22226	219.7 8.65	242.8 9.56	133.1 5.24	129.0 5.08	110.0 4.33	209.3 8.24
CS20STEEL	CLOSED							
CJ20T311S	3 11/16 in.							
CJ20T312S	3 3/4 in.							
CJ20T100S	100 mm	22230	270.3 10.64	283.2 11.15	148.1 5.83	144.0 5.67	135.1 5.32	239.5 9.43
CJ20T315S	3 15/16 in.							
CJ20T400S	4 in.							
CS22STEEL	CLOSED							
CJ22T110S	110 mm	23230	300.5 11.83	305.3 12.02	155.2 6.11	151.1 5.95	150.1 5.91	279.4 11.00
CJ22T407S	4 7/8 in.							
CJ22T408S	4 1/2 in.							
CJ22T115S	115 mm							
CS26STEEL	CLOSED	23234	300.5 11.83	305.3 12.02	155.2 6.11	151.1 5.95	150.1 5.91	279.4 11.00
CJ26T125S	125 mm							
CJ26T415S	4 15/16 in.							
CJ26T500S	5 in.							
CJ26T130S	130 mm	23234	300.5 11.83	305.3 12.02	155.2 6.11	151.1 5.95	150.1 5.91	279.4 11.00
CS30STEEL	CLOSED							
CJ30T507S	5 7/8 in.							
CJ30T508S	5 1/2 in.							
CJ30T140S	140 mm	23234	300.5 11.83	305.3 12.02	155.2 6.11	151.1 5.95	150.1 5.91	279.4 11.00
CJ30T515S	5 15/16 in.							
CJ30T600S	6 in.							
CJ30T150S	150 mm							
CS34STEEL	CLOSED	23234	300.5 11.83	305.3 12.02	155.2 6.11	151.1 5.95	150.1 5.91	279.4 11.00
CJ34T607S	6 7/8 in.							
CJ34T608S	6 1/2 in.							
CJ34T170S	170 mm							
CJ34T615S	6 15/16 in.	23234	300.5 11.83	305.3 12.02	155.2 6.11	151.1 5.95	150.1 5.91	279.4 11.00
CJ34T700S	7 in.							
CJ34T180S	180 mm							

Cover Part No.	Shaft Dia.	Bearing No.	Steel Cover Dimensions					
			A	B	C	D	E	F
	mm in.		mm in.	mm in.	mm in.	mm in.	mm in.	mm in.
CS20STEEL	CLOSED	22220	179.6 7.07	202.2 7.96	112.5 4.43	108.5 4.27	89.9 3.54	160.3 6.31
CJ20T311S	3 11/16 in.							
CJ20T312S	3 3/4 in.							
CJ20T100S	100 mm							
CJ20T315S	3 15/16 in.	22222	217.7 8.57	241.8 9.52	133.1 5.24	129.0 5.08	109.0 4.29	180.1 7.09
CJ20T400S	4 in.							
CS22STEEL	CLOSED							
CJ22T110S	110 mm							
CJ22T407S	4 7/8 in.	22226	219.7 8.65	242.8 9.56	133.1 5.24	129.0 5.08	110.0 4.33	209.3 8.24
CJ22T408S	4 1/2 in.							
CJ22T115S	115 mm							
CS26STEEL	CLOSED							
CJ26T125S	125 mm	22230	270.3 10.64	283.2 11.15	148.1 5.83	144.0 5.67	135.1 5.32	239.5 9.43
CJ26T415S	4 15/16 in.							
CJ26T500S	5 in.							
CJ26T130S	130 mm							
CS30STEEL	CLOSED	23230	270.3 10.64	283.2 11.15	148.1 5.83	144.0 5.67	135.1 5.32	239.5 9.43
CJ30T507S	5 7/8 in.							
CJ30T508S	5 1/2 in.							
CJ30T140S	140 mm							
CJ30T515S	5 15/16 in.	23234	300.5 11.83	305.3 12.02	155.2 6.11	151.1 5.95	150.1 5.91	279.4 11.00
CJ30T600S	6 in.							
CJ30T150S	150 mm							
CS34STEEL	CLOSED							
CJ34T607S	6 7/8 in.	23234	300.5 11.83	305.3 12.02	155.2 6.11	151.1 5.95	150.1 5.91	279.4 11.00
CJ34T608S	6 1/2 in.							
CJ34T170S	170 mm							
CJ34T615S	6 15/16 in.							
CJ34T700S	7 in.	23234	300.5 11.83	305.3 12.02	155.2 6.11	151.1 5.95	150.1 5.91	279.4 11.00
CJ34T180S	180 mm							

TABLE 6. TA/DV SERIES – TAPERED ADAPTER LOCK

Cover Part No.	Shaft Dia.	Bearing No.	Steel Cover Dimensions												
			A	B	C	D	E	F							
	mm in.		mm in.	mm in.	mm in.	mm in.	mm in.	mm in.							
CS09STEEL	CLOSED	22209	118.4 4.66	127.5 5.02	68.3 2.69	64.3 2.53	59.2 2.33	74.7 2.94							
CK09T107S	1 7/16 in.														
CK09T108S	1 1/2 in.														
CK09T040S	40 mm														
CS10STEEL	CLOSED	22210	118.4 4.66	130.0 5.12	70.9 2.79	66.8 2.63	59.2 2.33	79.8 3.14							
CK10T111S	1 11/16 in.														
CK10T112S	1 3/4 in.														
CK10T045S	45 mm														
CS11STEEL	CLOSED	22211	124.2 4.89	139.2 5.48	77.0 3.03	72.9 2.87	62.2 2.45	89.7 3.53							
CK11T115S	1 15/16 in.														
CK11T050S	50 mm														
CK11T200S	2 in.														
CS12STEEL	CLOSED	22212	123.7 4.87	136.4 5.37	74.4 2.93	70.4 2.77	62.0 2.44	98.6 3.88							
CK12T055S	55 mm														
CS13STEEL	CLOSED								22213	130.3 5.13	154.2 6.07	88.9 3.50	84.8 3.34	65.3 2.57	103.6 4.08
CK13T203S	2 3/16 in.														
CK13T204S	2 1/4 in.														
CK13T060S	60 mm														
CS15STEEL	CLOSED	22215	142.7 5.62	160.3 6.31	88.9 3.50	84.8 3.34	71.4 2.81	116.1 4.57							
CK15T207S	2 7/16 in.														
CK15T208S	2 1/2 in.														
CK15T065S	65 mm														
CS16STEEL	CLOSED	22216	144.8 5.70	162.3 6.39	89.9 3.54	85.9 3.38	72.4 2.85	116.1 4.57							
CK16T211S	2 11/16 in.														
CK16T212S	2 3/4 in.														
CK16T070S	70 mm														
CS17STEEL	CLOSED	22217	133.9 5.27	156.0 6.14	88.9 3.50	84.8 3.34	67.1 2.64	132.1 5.20							
CK17T215S	2 15/16 in.														
CK17T075S	75 mm														
CK17T300S	3 in.														
CS18STEEL	CLOSED	22218	159.5 6.28	182.9 7.20	102.9 4.05	98.8 3.89	79.8 3.14	139.4 5.49							
CK18T080S	80 mm														
CK18T303S	3 3/16 in.														
CK18T304S	3 1/4 in.														
CS19STEEL	CLOSED	22219	162.6 6.40	185.7 7.31	104.4 4.11	100.3 3.95	81.3 3.20	139.4 5.49							
CK19T085S	85 mm														

Cover Part No.	Shaft Dia.	Bearing No.	Steel Cover Dimensions					
			A	B	C	D	E	F
	mm in.		mm in.	mm in.	mm in.	mm in.	mm in.	mm in.
CS20STEEL	CLOSED	22220	170.4 6.71	193.0 7.60	108.0 4.25	103.9 4.09	85.3 3.36	160.3 6.31
CK20T307S	3 7/16 in.							
CK20T308S	3 1/2 in.							
CK20T090S	90 mm							
CS22STEEL	CLOSED	22222	208.5 8.21	232.9 9.17	128.5 5.06	124.5 4.90	104.4 4.11	180.1 7.09
CK22T315S	3 15/16 in.							
CK22T400S	4 in.							
CK22T100S	100 mm							
CS24STEEL	CLOSED	22224	213.6 8.41	237.7 9.36	131.1 5.16	127.0 5.00	106.7 4.20	180.1 7.09
CK24T403S	4 3/16 in.							
CK24T404S	4 1/4 in.							
CK24T110S	110 mm							
CS26STEEL	CLOSED	22226	210.6 8.29	233.9 9.21	128.5 5.06	124.5 4.90	105.4 4.15	209.3 8.24
CK26T407S	4 7/16 in.							
CK26T408S	4 1/2 in.							
CK26T115S	115 mm							
CS28STEEL	CLOSED	22228	214.6 8.45	238.0 9.37	130.6 5.14	126.5 4.98	107.2 4.22	209.3 8.24
CK28T415S	4 15/16 in.							
CK28T500S	5 in.							
CK28T125S	125 mm							

STEEL COVER DIMENSIONS – continued

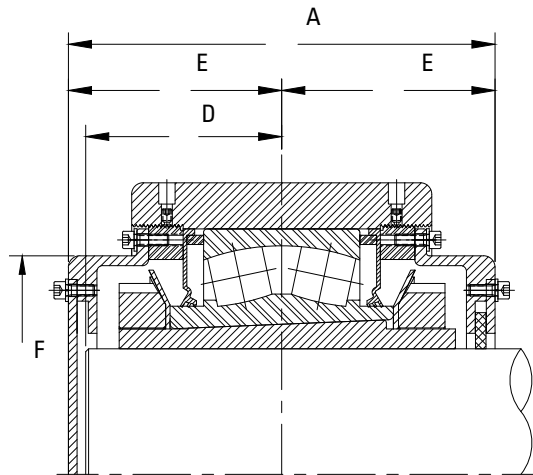

TABLE 7. TAA/DAA SERIES – TAPERED ADAPTER LOCK

Cover Part No.	Shaft Dia.	Bearing No.	Steel Cover Dimensions			
			A	D	E	F
	mm in.		mm in.	mm in.	mm in.	mm in.
CS32STEEL	CLOSED	23132	235.1 9.26	108.2 4.26	117.6 4.63	240.5 9.47
CK32T135S	135 mm					
CK32T506S	5 3/8 in.					
CK32T507S	5 7/16 in.					
CK32T508S	5 1/2 in.					
CK32T140S	140 mm	23134	236.6 9.32	108.7 4.28	118.3 4.66	243.4 9.58
CS34LSTEEL	CLOSED					
CK34T513S	5 13/16 in.					
CK34T514S	5 7/8 in.					
CK34T150S	150 mm					
CK34T515S	5 15/16 in.	23136	237.1 9.34	107.0 4.21	118.6 4.67	255.9 10.08
CK34T600S	6 in.					
CS36STEEL	CLOSED					
CK36T160S	160 mm					
CK36T605S	6 5/16 in.					
CK36T606S	6 3/8 in.	23138	255.4 10.06	118.1 4.65	127.7 5.03	272.3 10.72
CK36T607S	6 7/16 in.					
CK36T608S	6 1/2 in.					
CS38STEEL	CLOSED					
CK38T170S	170 mm					
CK38T613S	6 13/16 in.	23140	258.8 10.19	119.4 4.70	129.4 5.09	287.4 11.31
CK38T614S	6 7/8 in.					
CK38T615S	6 15/16 in.					
CK38T700S	7 in.					
CS40STEEL	CLOSED					
CK40T180S	180 mm	23144	297.7 11.72	136.1 5.36	148.9 5.86	314.0 12.36
CK40T702S	7 1/8 in.					
CK40T703S	7 3/16 in.					
CK40T704S	7 1/4 in.					
CS44STEEL	CLOSED					
CK44T713S	7 13/16 in.	23148	300.0 11.81	136.7 5.38	150.0 5.91	346.4 13.64
CK44T200S	200 mm					
CK44T714S	7 7/8 in.					
CK44T715S	7 15/16 in.					
CK44T800S	8 in.					
CS48STEEL	CLOSED	23152	330.0 12.99	151.0 5.95	165.0 6.50	381.0 15.00
CK48T807S	8 7/16 in.					
CK48T808S	8 1/2 in.					
CK48T220S	220 mm					
CK48T815S	8 15/16 in.					
CK48T900S	9 in.	23152	330.0 12.99	151.0 5.95	165.0 6.50	381.0 15.00
CS52STEEL	CLOSED					
CK52T907S	9 7/16 in.					
CK52T240S	240 mm	23152	330.0 12.99	151.0 5.95	165.0 6.50	381.0 15.00
CK52T908S	9 1/2 in.					

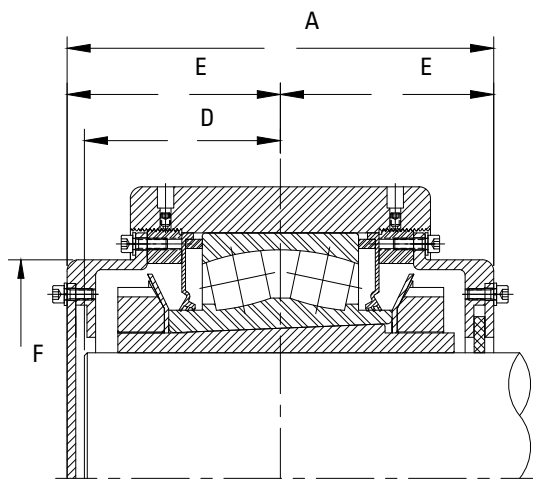

TABLE 7. TAA/DAA SERIES – TAPERED ADAPTER LOCK (CONTINUED)

Cover Part No.	Shaft Dia.	Bearing No.	Steel Cover Dimensions				Cover Part No.	Shaft Dia.	Bearing No.	Steel Cover Dimensions			
			A	D	E	F				A	D	E	F
	mm in.		mm in.	mm in.	mm in.	mm in.		mm in.		mm in.	mm in.	mm in.	mm in.
CS56STEEL	CLOSED	23156	365.2 14.38	167.0 6.58	182.6 7.19	388.4 15.29	CS68STEEL	CLOSED	23168	412.6 16.24	185.2 7.29	206.3 8.12	482.1 18.98
CK56T915S	9 1/16 in.						CK68T1207S	12 7/16 in.					
CK56T1000S	10 in.						CK68T1208S	12 1/2 in.					
CK56T260S	260 mm						CK68T320S	320 mm					
CK56T1007S	10 7/16 in.						CS72STEEL	CLOSED					
CK56T1008S	10 1/2 in.	23172	377.5 14.86	170.6 6.71	188.8 7.43	432.8 17.04	CK72T1215S	12 15/16 in.	23176	435.2 17.13	196.8 7.75	217.6 8.57	521.6 20.54
CS60STEEL	CLOSED						CK72T1300S	13 in.					
CK60T1015S	10 15/16 in.						CK72T340S	340 mm					
CK60T1100S	11 in.						CK72T1307S	13 7/16 in.					
CK60T280S	280 mm						CK72T1308S	13 1/2 in.					
CS64STEEL	CLOSED	23164	390.5 15.37	176.7 6.96	195.2 7.69	450.8 17.75	CS76STEEL	CLOSED	23176	458.9 18.07	204.2 8.04	229.5 9.03	554.3 21.82
CK64T1107S	11 7/16 in.						CK76T1315S	13 15/16 in.					
CK64T1108S	11 1/2 in.						CK76T1400S	14 in.					
CK64T300S	300 mm						CK76T360S	360 mm					
CK64T1115S	11 15/16 in.						CS80STEEL	CLOSED					
CK64T1200S	12 in.	23180	482.1 18.98	215.6 8.49	241.1 9.49	582.6 22.94	CK80T1415S	14 15/16 in.	23180	482.1 18.98	215.6 8.49	241.1 9.49	582.6 22.94
							CK80T380S	380 mm					
							CK80T1500S	15 in.					

URETHANE

CLOSED-END COVER DIMENSIONS

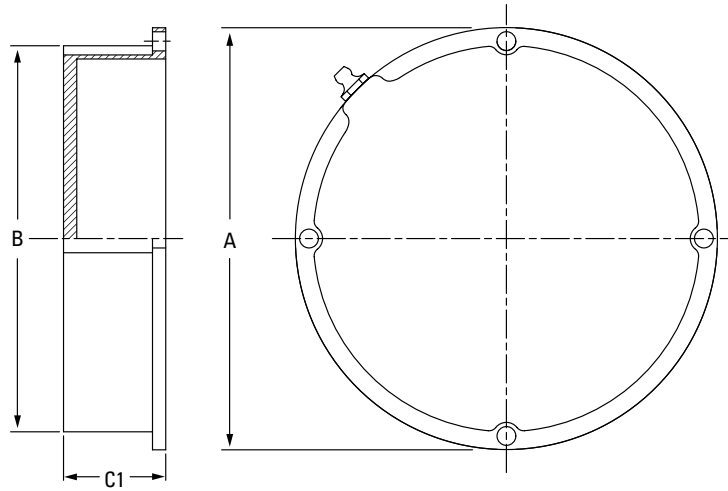

TABLE 8. CLOSED-END COVER DIMENSIONS

Cover Part No. ⁽¹⁾	A	B	C1 ⁽²⁾
	mm in.	mm in.	mm in.
CS08	81.5 3.21	76.7 3.02	31.6 1.25
CS09	86.6 3.41	81.6 3.21	31.6 1.25
CS10	91.9 3.62	86.6 3.41	31.6 1.25
CS11	101.9 4.01	96.6 3.81	31.6 1.25
CS12V	110.5 4.35	105.6 4.16	31.6 1.25
CS13/CS14V	119.4 4.70	110.5 4.35	27.3 1.08
CS15/CS16V	130.0 5.12	122.9 4.84	33.0 1.30
CS17	149.9 5.90	139.0 5.47	31.1 1.22
CS18/CS19V	160.3 6.31	146.5 5.77	38.8 1.53
CS20	179.8 7.08	167.2 6.58	44.5 1.75
CS22	200.4 7.89	187.2 7.37	52.7 2.07
CS24	200.4 7.89	187.2 7.37	52.7 2.07
CS26/CS28V	230.1 9.06	216.2 8.51	56.9 2.24
CS30	270.5 10.65	254.0 10.00	56.9 2.24
CS34	309.9 12.20	295.2 11.62	73.3 2.89

⁽¹⁾Cover part number, CSXX, is determined by the bearing insert series of unit on which cover will be installed. See nomenclature guide on page 13 to determine bearing insert series.

⁽²⁾Extended covers available upon request.

OPEN-END COVERS WITH DR SEALS

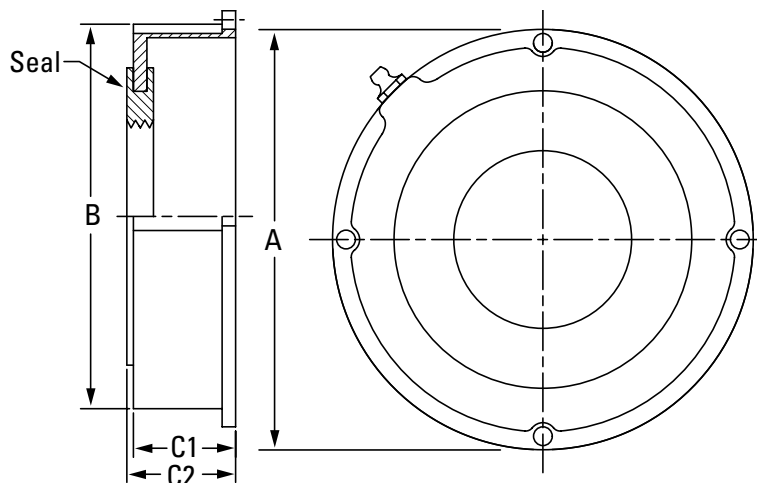

TABLE 9. V-LOCK SERIES – STRAIGHT BORE EQUIVALENT – OPEN-END COVER WITH DR SEAL – (QV[V]...P, PL, SN, PF, PR, C, CW, F, FL, FY, FX, TU)

Cover Part No.	Shaft Dia.	A	B	C1	C2
	mm in.	mm in.	mm in.	mm in.	mm in.
CVDR11-115	1 1/16 in.	101.9	96.6	31.6	34.2
CVDR11-200	2 in.	4.01	3.81	1.25	1.35
CVDR11-050MM	50 mm				
CVDR12-203	2 3/16 in.	110.5	105.6	31.6	34.2
CVDR12-204	2 1/4 in.	4.35	4.16	1.25	1.35
CVDR12-055MM	55 mm				
CVDR14-060MM	60 mm				
CVDR14-207	2 7/16 in.	119.4	110.5	27.3	29.8
CVDR14-208	2 1/2 in.	4.70	4.35	1.08	1.18
CVDR14-065MM	65 mm				
CVDR16-211	2 1/16 in.				
CVDR16-212	2 3/4 in.				
CVDR16-070MM	70 mm	130.0	122.9	33.0	35.5
CVDR16-215	2 1/16 in.	5.12	4.84	1.30	1.40
CVDR16-300	3 in.				
CVDR16-075MM	75 mm				
CVDR19-303	3 3/16 in.				
CVDR19-304	3 1/4 in.				
CVDR19-080MM	80 mm	160.3	146.5	38.8	41.4
CVDR19-085MM	85 mm	6.31	5.77	1.53	1.63
CVDR19-307	3 7/16 in.				
CVDR19-308	3 1/2 in.				
CVDR19-090MM	90 mm				
CVDR22-311	3 1/16 in.				
CVDR22-312	3 3/4 in.				
CVDR22-100MM	100 mm	200.4	187.2	52.7	55.2
CVDR22-315	3 1/16 in.	7.89	7.37	2.07	2.17
CVDR22-400	4 in.				
CVDR26-110MM	110 mm				
CVDR26-407	4 7/16 in.	230.1	216.2	56.9	59.4
CVDR26-408	4 1/2 in.	9.06	8.51	2.24	2.34
CVDR26-115MM	115 mm				
CVDR28-125MM	125 mm				
CVDR28-415	4 1/16 in.	230.1	216.2	56.9	59.4
CVDR28-500	5 in.	9.06	8.51	2.24	2.34
CVDR28-130MM	130 mm				

TABLE 10. V-LOCK SERIES – TAPERED ADAPTER EQUIVALENT – OPEN-END COVER WITH DR SEAL – (QV[V]...PA, PN, PKT, PK, PH, PG, FC, FB, MC)

Cover Part No.	Shaft Dia.	A	B	C1	C2
	mm in.	mm in.	mm in.	mm in.	mm in.
CVDR11-115	1 1/16 in.	101.9	96.6	31.6	34.2
CVDR11-200	2 in.	4.01	3.81	1.25	1.35
CVDR11-050MM	50 mm				
CVDR13-203	2 3/16 in.	119.4	110.5	27.3	29.8
CVDR13-204	2 1/4 in.	4.70	4.35	1.08	1.18
CVDR13-055MM	55 mm				
CVDR15-060MM	60 mm				
CVDR15-207	2 7/16 in.	130.0	122.9	33.0	35.5
CVDR15-208	2 1/2 in.	5.12	4.84	1.30	1.40
CVDR15-065MM	65 mm				
CVDR17-211	2 1/16 in.				
CVDR17-212	2 3/4 in.				
CVDR17-070MM	70 mm	149.9	139.0	31.1	33.6
CVDR17-215	2 1/16 in.	5.90	5.47	1.22	1.32
CVDR17-300	3 in.				
CVDR16-075MM	75 mm				
CVDR20-303	3 3/16 in.				
CVDR20-304	3 1/4 in.				
CVDR20-080MM	80 mm	179.8	167.2	44.5	47.0
CVDR20-085MM	85 mm	7.08	6.58	1.75	1.85
CVDR20-307	3 7/16 in.				
CVDR19-308	3 1/2 in.				
CVDR19-090MM	90 mm				
CVDR22-311	3 1/16 in.				
CVDR22-312	3 3/4 in.				
CVDR22-100MM	100 mm	200.4	187.2	52.7	55.2
CVDR22-315	3 1/16 in.	7.89	7.37	2.07	2.17
CVDR22-400	4 in.				
CVDR26-110MM	110 mm				
CVDR26-407	4 7/16 in.	230.1	216.2	56.9	59.4
CVDR26-408	4 1/2 in.	9.06	8.51	2.24	2.34
CVDR26-115MM	115 mm				
CVDR28-125MM	125 mm				
CVDR28-415	4 1/16 in.	230.1	216.2	56.9	59.4
CVDR28-500	5 in.	9.06	8.51	2.24	2.34
CVDR28-130MM	130 mm				

TABLE 11. CL AND EC SERIES—OPEN-END COVER WITH DR SEAL

Cover Part No.	Shaft Dia.	A	B	C1	C2
	mm in.	mm in.	mm in.	mm in.	mm in.
CJDR035MM	35 mm	97.0 3.82	76.7 3.02	31.8 1.25	34.3 1.35
CJDR107	1 7/16 in.				
CJDR108	1 1/2 in.				
CJDR040MM	40 mm	101.9 4.01	81.6 3.21	31.8 1.25	34.3 1.35
CJDR111	1 11/16 in.				
CJDR112	1 3/4 in.				
CJDR045MM	45 mm	106.9 4.21	86.6 3.41	31.8 1.25	34.3 1.35
CJDR115	1 15/16 in.				
CJDR200	2 in.				
CJDR050MM	50 mm	117.1 4.61	96.8 3.81	31.8 1.25	34.3 1.35
CJDR203	2 3/16 in.				
CJDR204	2 1/4 in.				
CJDR055MM	55 mm	132.1 5.20	110.49 4.35	27.4 1.08	30.0 1.18
CJDR060MM	60 mm				
CJDR207	2 7/16 in.				
CJDR208	2 1/2 in.				
CJDR065MM	65 mm	142 5.59	122.9 4.84	33.0 1.30	35.6 1.40
CJDR211	2 11/16 in.				
CJDR070MM	70 mm				
CJDR212	2 3/4 in.				
CJDR215	2 15/16 in.				
CJDR300	3 in.				
CJDR075MM	75 mm	168.1 6.62	149.1 5.87	38.9 1.53	41.4 1.63
CJDR303	3 3/16 in.				
CJDR304	3 1/4 in.				
CJDR080MM	80 mm	192 7.56	174.8 6.88	44.5 1.75	47.0 1.85
CJDR085MM	85 mm				
CJDR307	3 7/16 in.				
CJDR308	3 1/2 in.				
CJDR090MM	90 mm	212.1 8.35	194.8 7.67	52.6 2.07	55.1 2.17
CJDR315	3 15/16 in.				
CJDR400	4 in.				
CJDR100MM	100 mm	241.3 9.50	223.8 8.81	56.9 2.24	59.4 2.34
CJDR110MM	110 mm				
CJDR407	4 7/16 in.				
CJDR408	4 1/2 in.				
CJDR115MM	115 mm	271.6 10.69	254.0 10.00	56.9 2.24	59.4 2.34
CJDR125MM	125 mm				
CJDR415	4 15/16 in.				
CJDR500	5 in.				
CJDR130MM	130 mm	304.8 12.00	287.3 11.31	56.9 2.24	59.4 2.34
CJDR507	5 7/16 in.				
CJDR508	5 1/2 in.				
CJDR140MM	140 mm	304.8 12.00	287.3 11.31	56.9 2.24	59.4 2.34
CJDR515	5 15/16 in.				
CJDR600	6 in.				
CJDR150MM	150 mm	304.8 12.00	287.3 11.31	56.9 2.24	59.4 2.34
CJDR607	6 7/16 in.				
CJDR608	6 1/2 in.				
CJDR170MM	170 mm	304.8 12.00	287.3 11.31	56.9 2.24	59.4 2.34
CJDR615	6 15/16 in.				
CJDR700	7 in.				
CJDR180MM	180 mm	304.8 12.00	287.3 11.31	56.9 2.24	59.4 2.34
CJDR707	7 7/16 in.				
CJDR708	7 1/2 in.				

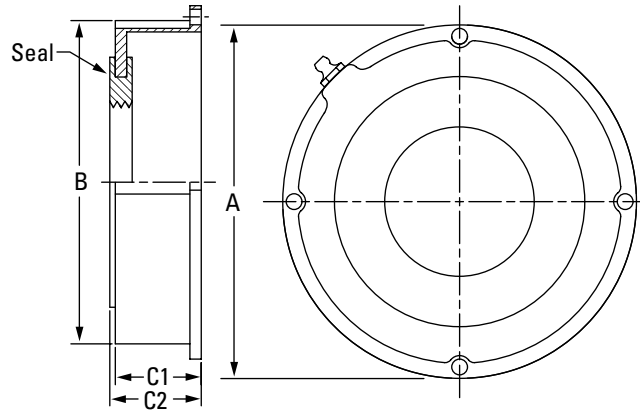

TABLE 12. TA/DV SERIES—OPEN-END COVER WITH DR SEAL

Cover Part No.	Shaft Dia.	A	B	C1	C2
	mm in.	mm in.	mm in.	mm in.	mm in.
CKDR107	1 7/16 in.	101.9 4.01	81.5 3.21	31.8 1.25	34.3 1.35
CKDR108	1 1/2 in.				
CKDR040MM	40 mm				
CKDR111	1 11/16 in.	106.9 4.21	86.6 3.41	31.8 1.25	34.3 1.35
CKDR112	1 3/4 in.				
CKDR045MM	45 mm				
CKDR115	1 15/16 in.	117.1 4.61	96.8 3.81	31.8 1.25	34.3 1.35
CKDR200	2 in.				
CKDR050MM	50 mm				
CKDR055MM	55 mm	126.0 4.96	105.7 4.16	31.8 1.25	34.3 1.35
CKDR203	2 3/16 in.				
CKDR204	2 1/4 in.				
CKDR060MM	60 mm	132.1 5.20	116.1 4.57	27.4 1.08	30.0 1.18
CKDR207	2 7/16 in.				
CKDR208	2 1/2 in.				
CKDR065MM	65 mm	142.0 5.59	122.9 4.84	33.0 1.30	35.6 1.40
CKDR211	2 11/16 in.				
CKDR212	2 3/4 in.				
CKDR070MM	70 mm	142.0 5.59	122.9 4.84	33.0 1.30	35.6 1.40
CKDR215	2 15/16 in.				
CKDR300	3 in.				
CKDR075MM	75 mm	160.5 6.32	141.5 5.57	31.0 1.22	33.5 1.32
CKDR080MM	80 mm				
CKDR303	3 3/16 in.				
CKDR304	3 1/4 in.				
CKDR085MM	85 mm	168.1 6.62	149.1 5.87	38.9 1.53	41.4 1.63
CKDR307	3 7/16 in.				
CKDR308	3 1/2 in.				
CKDR090MM	90 mm	192.0 7.56	174.8 6.88	44.5 1.75	47.0 1.85
CKDR315	3 15/16 in.				
CKDR400	4 in.				
CKDR100MM	100 mm	212.1 8.35	194.8 7.67	52.6 2.07	55.1 2.17
CKDR403	4 3/16 in.				
CKDR404	4 1/4 in.				
CKDR110MM	110 mm	212.1 8.35	194.8 7.67	52.6 2.07	55.1 2.17
CKDR407	4 7/16 in.				
CKDR408	4 1/2 in.				
CKDR115MM	115 mm	241.3 9.50	223.8 8.81	56.9 2.24	59.4 2.34
CKDR415	4 15/16 in.				
CKDR500	5 in.				
CKDR125MM	125 mm	241.3 9.50	223.8 8.81	56.9 2.24	59.4 2.34
CKDR507	5 7/16 in.				
CKDR508	5 1/2 in.				

OPEN-END COVERS WITH VR SEALS

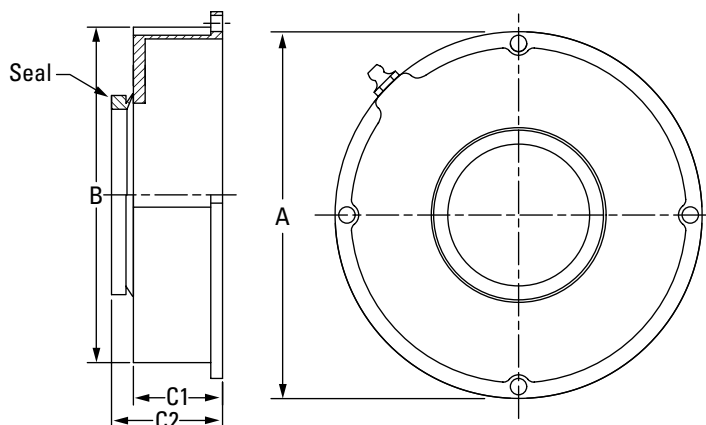

TABLE 13. V-LOCK SERIES – STRAIGHT BORE EQUIVALENT – OPEN-END COVER WITH VR SEAL – (QV[V])...P, PL, SN, PF, PR, PX, PXT, C, CW, F, FL, FY, FX, TU)

Cover Part No. ⁽¹⁾	Shaft Dia.	A	B	C1	C2
	mm in.	mm in.	mm in.	mm in.	mm in.
CVVR11	1 15/16 in.	117.1	96.8	31.8	40.6
	2 in.				
	50 mm				
CVVR12	2 3/16 in.	126.0	105.7	31.8	40.6
	2 1/4 in.				
	55 mm				
CVVR14	2 7/16 in.	132.1	116.1	27.4	36.3
	2 1/2 in.				
	65 mm				
CVVR16	2 11/16 in.	142.0	122.9	33.0	44.0
	2 3/4 in.				
	70 mm				
	2 15/16 in.				
CVVR19	3 in.	168.1	149.1	38.9	50.0
	75 mm				
	3 3/16 in.				
	3 1/4 in.				
CVVR22	80 mm	212.1	194.8	52.6	63.5
	85 mm				
	3 7/16 in.				
	3 1/2 in.				
CVVR26	90 mm	241.3	223.8	56.9	69.6
	100 mm				
	4 in.				
	110 mm				
CVVR28	4 7/16 in.	241.3	223.8	56.9	69.6
	4 1/2 in.				
	115 mm				
CVVR28	125 mm	241.3	223.8	56.9	69.6
	4 15/16 in.				
	5 in.				
CVVR28	130 mm	241.3	223.8	56.9	69.6
	5 in.				
	130 mm				

⁽¹⁾Please refer to bore size when choosing cover for straight-bore V-Lock.

TABLE 14. V-LOCK SERIES – TAPERED ADAPTER EQUIVALENT – OPEN-END COVER WITH VR SEAL – (QV[V])...PA, PN, PKT, PK, PH, PG, FC, FB, MC)

Cover Part No.	Shaft Dia.	A	B	C1	C2
	mm in.	mm in.	mm in.	mm in.	mm in.
CKVR11	1 15/16 in.	117.1	96.8	31.8	40.6
	2 in.				
	50 mm				
CKVR13	2 3/16 in.	132.1	116.1	27.4	36.3
	2 1/4 in.				
	55 mm				
CKVR15	2 7/16 in.	142.0	122.9	33.0	41.9
	2 1/2 in.				
	65 mm				
CKVR17	2 11/16 in.	160.6	141.5	31.0	41.9
	2 3/4 in.				
	70 mm				
	2 15/16 in.				
CKVR20	3 in.	192.0	174.8	44.4	55.4
	75 mm				
	3 3/16 in.				
	3 1/4 in.				
CKVR22	80 mm	212.1	194.8	52.6	63.5
	85 mm				
	3 7/16 in.				
	3 1/2 in.				
CKVR24	90 mm	241.3	223.8	52.6	63.5
	100 mm				
	4 in.				
	110 mm				
CKVR26	4 7/16 in.	241.3	223.8	56.9	69.6
	4 1/2 in.				
	115 mm				
CKVR28	125 mm	241.3	223.8	56.9	69.6
	4 15/16 in.				
	5 in.				
CKVR28	130 mm	241.3	223.8	56.9	69.6
	5 in.				
	130 mm				

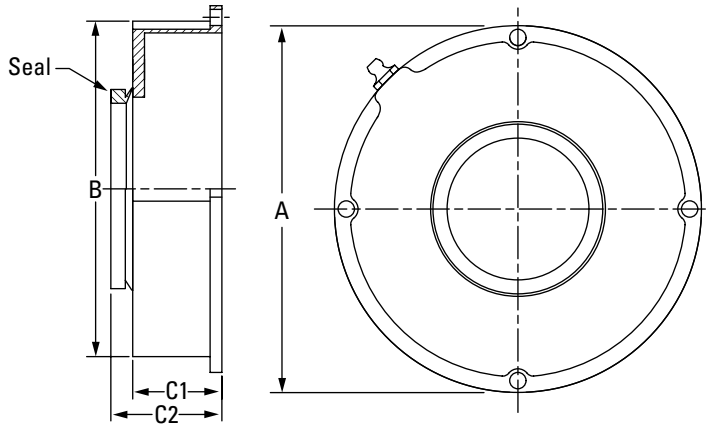

TABLE 15. CL AND EC SERIES—OPEN-END COVER WITH VR SEAL

Cover Part No.	Shaft Dia.	A	B	C1	C2
	mm in.	mm in.	mm in.	mm in.	mm in.
CJVR08	35 mm	97.0	76.7	31.8	39.4
	1 7/16 in.	3.82	3.02	1.25	1.55
	1 1/2 in.				
CJVR09	40 mm	101.9	81.5	31.8	40.6
	1 11/16 in.	4.01	3.21	1.25	1.60
	1 3/4 in.				
CJVR10	45 mm	106.9	86.6	31.8	40.6
	1 15/16 in.	4.21	3.41	1.25	1.60
	2 in.				
CJVR11	50 mm	117.1	96.8	31.8	40.6
	2 3/16 in.	4.61	3.81	1.25	1.60
	2 1/4 in.				
CJVR13	55 mm	132.1	116.1	27.4	36.3
	2 1/8 in.	5.20	4.57	1.08	1.43
	2 1/2 in.				
CJVR15	60 mm	142.0	122.9	33.0	44.0
	2 3/8 in.	5.59	4.84	1.30	1.73
	2 15/16 in.				
CJVR18	70 mm	168.1	149.1	38.9	49.8
	2 3/4 in.	6.62	5.87	1.53	1.96
	2 7/8 in.				
CJVR20	75 mm	192.0	174.8	44.5	55.4
	3 in.	7.56	6.88	1.75	2.18
	3 1/8 in.				
CJVR22	80 mm	212.1	194.8	52.6	65.3
	3 1/4 in.	8.35	7.67	2.07	2.57
	3 1/2 in.				
CJVR26	85 mm	241.3	223.8	56.9	69.6
	3 3/8 in.	9.50	8.81	2.24	2.74
	3 1/2 in.				

TABLE 16. TA/DV SERIES—OPEN-END COVER WITH VR SEAL

Cover Part No.	Shaft Dia.	A	B	C1	C2
	mm in.	mm in.	mm in.	mm in.	mm in.
CKVR09	40 mm	101.9	81.5	31.8	39.4
	1 7/16 in.	4.01	3.21	1.25	1.55
	1 1/2 in.				
CKVR10	45 mm	106.9	86.6	31.8	40.6
	1 11/16 in.	4.21	3.41	1.25	1.6
	1 3/4 in.				
CKVR11	50 mm	117.1	96.8	31.8	40.6
	1 15/16 in.	4.61	3.81	1.25	1.60
	2 in.				
CKVR12	55 mm	126.0	105.7	31.8	40.6
	2 1/8 in.	4.96	4.16	1.25	1.6
	2 1/4 in.				
CKVR13	60 mm	132.1	116.1	27.4	36.3
	2 3/8 in.	5.20	4.57	1.08	1.43
	2 1/2 in.				
CKVR15	65 mm	142.0	122.9	33.0	41.9
	2 5/8 in.	5.59	4.84	1.30	1.65
	2 7/8 in.				
CKVR16	70 mm	142.0	122.9	33.0	41.9
	2 3/4 in.	5.59	4.84	1.30	1.65
	2 7/8 in.				
CKVR17	75 mm	160.5	141.5	31.0	41.9
	3 in.	6.32	5.57	1.22	1.65
	3 1/8 in.				
CKVR18	80 mm	168.1	149.1	38.9	49.8
	3 1/4 in.	6.62	5.87	1.53	1.96
	3 1/2 in.				
CKVR19	85 mm	168.1	149.1	38.9	49.8
	3 3/8 in.	6.62	5.87	1.53	1.96
	3 1/2 in.				
CKVR20	90 mm	192.0	174.8	44.5	55.4
	3 5/8 in.	7.56	6.88	1.75	2.18
	3 3/4 in.				
CKVR22	95 mm	212.1	194.8	52.6	63.5
	3 7/8 in.	8.35	7.67	2.07	2.50
	4 in.				
CKVR24	100 mm	212.1	194.8	52.6	63.5
	4 in.	8.35	7.67	2.07	2.50
	4 1/8 in.				
CKVR26	105 mm	241.3	223.8	56.9	69.6
	4 1/4 in.	9.50	8.81	2.24	2.74
	4 1/2 in.				
CKVR28	110 mm	241.3	223.8	56.9	69.6
	4 3/8 in.	9.50	8.81	2.24	2.74
	4 1/2 in.				

UFP AND HSY FLANGE BLOCK BACKING PLATE DIMENSIONS

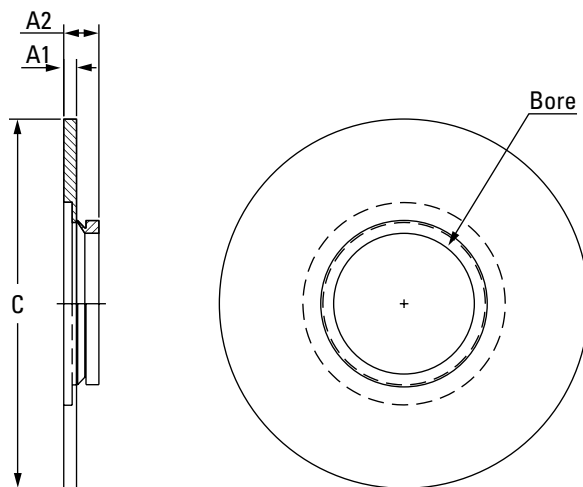

TABLE 17. UFP BACKING PLATE DIMENSIONS⁽¹⁾

Cover Part No.	Shaft Dia.	A1	A2	C
	mm in.	mm in.	mm in.	mm in.
UFP035MM	35 mm			
UFP107	1 7/16 in.	5.1	12.7	95.3
UFP108	1 1/2 in.	0.20	0.50	3.75
UFP111	1 11/16 in.			
UFP040MM	40 mm	5.1	14.0	105.9
UFP112	1 3/4 in.	0.20	0.55	4.17
UFP045MM	45 mm			
UFP115	1 15/16 in.			
UFP200	2 in.	3.8	12.7	106.4
UFP050MM	50 mm	0.15	0.50	4.19
UFP203	2 3/16 in.			
UFP204	2 1/4 in.	6.4	15.2	114.6
UFP055MM	55 mm	0.25	0.60	4.51
UFP060MM	60 mm			
UFP207	2 7/16 in.	5.1	14.0	146.1
UFP208	2 1/2 in.	0.20	0.55	5.75
UFP065MM	65 mm			
UFP211	2 11/16 in.			
UFP070MM	70 mm			
UFP212	2 3/4 in.	5.1	16.0	146.6
UFP215	2 15/16 in.	0.20	0.63	5.77
UFP300	3 in.			
UFP075MM	75 mm			
UFP303	3 3/16 in.			
UFP304	3 1/4 in.			
UFP080MM	80 mm	5.1	16.0	187.5
UFP085MM	85 mm	0.20	0.63	7.38
UFP307	3 7/16 in.			
UFP308	3 1/2 in.			
UFP090MM	90 mm			
UFP315	3 15/16 in.			
UFP400	4 in.	5.1	16.0	206.5
UFP100MM	100 mm	0.20	0.63	8.13
UFP110MM	110 mm			
UFP407	4 7/16 in.	5.1	17.8	215.9
UFP408	4 1/2 in.	0.20	0.70	8.50
UFP115MM	115 mm			
UFP125MM	125 mm			
UFP415	4 15/16 in.	5.1	17.8	299
UFP500	5 in.	0.20	0.70	11.77
UFP130MM	130 mm			

⁽¹⁾Actual backing plate may differ from drawing.

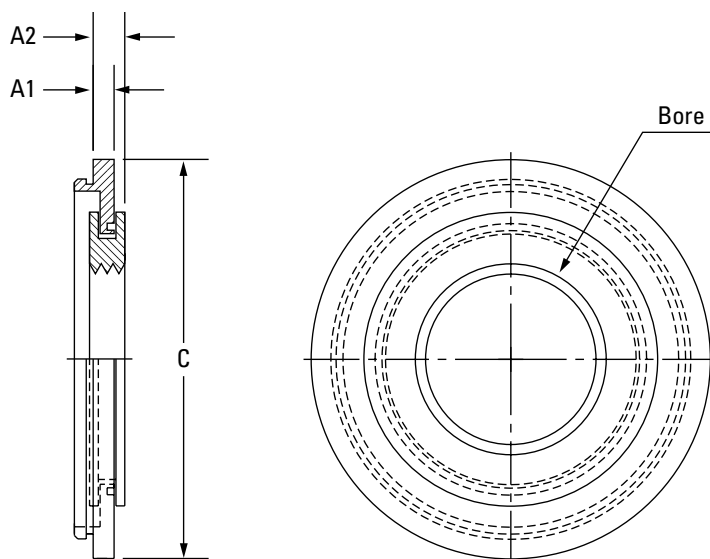

TABLE 18. HSY BACKING PLATE DIMENSIONS

Cover Part No.	Shaft Dia.	A1	A2	C
	mm in.	mm in.	mm in.	mm in.
HSY035MM	35 mm	5.1 0.20	7.6 0.30	85.9 3.38
HSY107	1 7/16 in.			
HSY108	1 1/2 in.			
HSY111	1 11/16 in.	8.9 0.35	11.4 0.45	101.6 4.00
HSY040MM	40 mm			
HSY112	1 3/4 in.			
HSY045MM	45 mm	5.1 0.20	7.6 0.30	108.0 4.25
HSY115	1 15/16 in.			
HSY200	2 in.			
HSY050MM	50 mm	5.1 0.20	7.6 0.30	120.1 4.73
HSY203	2 3/16 in.			
HSY204	2 1/4 in.			
HSY055MM	55 mm	6.4 0.25	8.9 0.35	133.4 5.25
HSY060MM	60 mm			
HSY207	2 7/16 in.			
HSY208	2 1/2 in.	6.4 0.25	8.9 0.35	155.7 6.13
HSY065MM	65 mm			
HSY211	2 11/16 in.			
HSY070MM	70 mm	5.1 0.20	7.6 0.30	181.1 7.13
HSY212	2 3/4 in.			
UPF215	2 15/16 in.			
HSY300	3 in.	5.1 0.20	7.6 0.30	199.9 7.87
HSY075MM	75 mm			
HSY303	3 3/16 in.			
HSY304	3 1/4 in.	7.6 0.30	10.2 0.40	245.0 10.00
HSY080MM	80 mm			
HSY085MM	85 mm			
HSY307	3 7/16 in.	7.6 0.30	10.2 0.40	245.0 10.00
HSY308	3 1/2 in.			
HSY090MM	90 mm			
HSY315	3 15/16 in.	7.6 0.30	10.2 0.40	245.0 10.00
HSY400	4 in.			
HSY100MM	100 mm			
HSY110MM	110 mm	7.6 0.30	10.2 0.40	245.0 10.00
HSY407	4 7/16 in.			
HSY408	4 1/2 in.			
HSY115MM	115 mm			

SEAL AND COVER OPTIONS • UFP AND HSY FLANGE BLOCK BACKING PLATE DIMENSIONS

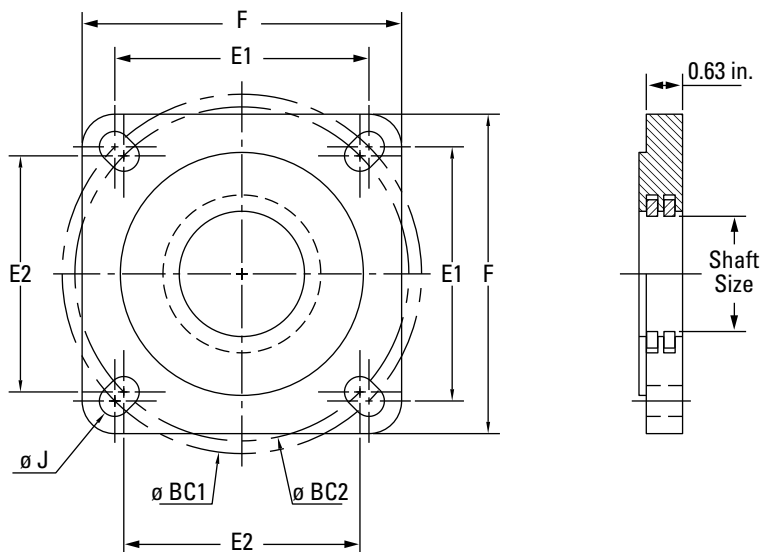

TABLE 19. STEEL BACKING PLATES AVAILABLE IN ECCENTRIC AND SET SCREW LOCKING HOUSING STYLES QMF/QAF AND QMFL/QAFL

Part Number	Shaft Dia.	F	E1	E2	BC1	BC2	J	Bolt Size	Weight
	mm in.	mm in.	mm in.	mm in.	mm in.	mm in.	mm [+1.5/-0] in. [+0.063/-0]	mm in.	kg lb.
BP10T115S	1 1/16 in.	139.7 5.50	111.1 4.38	103.3 4.07	157.1 6.19	146.1 5.75	13.5 0.53	12 1/2	2.0 4.5
BP10T200S	2 in.								
BP10T050S	50 mm								
BP11T203S	2 3/16 in.	157.2 6.19	123.8 4.88	114.5 4.51	175.1 6.89	161.9 6.38	16.7 0.66	16 5/8	2.8 6.1
BP11T204S	2 1/4 in.								
BP11T055S	55 mm								
BP13T060S	60 mm	168.4 6.63	136.5 5.38	121.2 4.77	193.1 7.60	171.5 6.75	16.7 0.66	16 5/8	3.0 6.7
BP13T207S	2 7/16 in.								
BP13T208S	2 1/2 in.								
BP13T065S	65 mm	189.0 7.44	152.4 6.00	141.4 5.57	215.5 8.49	200.0 7.88	21.0 0.83	20 3/4	3.9 8.6
BP15T211S	2 1/16 in.								
BP15T212S	2 3/4 in.								
BP15T070S	70 mm	219.2 8.63	178.0 7.01	170.6 6.72	251.7 9.91	241.3 9.50	21.0 0.83	20 3/4	5.4 12.0
BP15T215S	2 15/16 in.								
BP15T300S	3 in.								
BP15T075S	75 mm	253.2 9.97	196.9 7.75	193.1 7.60	278.4 10.96	273.1 10.75	27.0 1.06	24 7/8	7.1 15.6
BP18T303S	3 3/16 in.								
BP18T304S	3 1/4 in.								
BP18T080S	80 mm	219.2 8.63	178.0 7.01	170.6 6.72	251.7 9.91	241.3 9.50	21.0 0.83	20 3/4	5.4 12.0
BP18T085S	85 mm								
BP18T307S	3 7/16 in.								
BP18T308S	3 1/2 in.	253.2 9.97	196.9 7.75	193.1 7.60	278.4 10.96	273.1 10.75	27.0 1.06	24 7/8	7.1 15.6
BP18T090S	90 mm								
BP20T311S	3 1/16 in.								
BP20T312S	3 3/4 in.	253.2 9.97	196.9 7.75	193.1 7.60	278.4 10.96	273.1 10.75	27.0 1.06	24 7/8	7.1 15.6
BP20T315S	3 15/16 in.								
BP20T400S	4 in.								
BP20T100S	100 mm	276.4 10.88	222.3 8.75	N/A	314.3 12.38	N/A	25.0 0.98	24 7/8	8.4 18.5
BP22T110S	110 mm								
BP22T407S	4 7/16 in.								
BP22T408S	4 1/2 in.	276.4 10.88	222.3 8.75	N/A	314.3 12.38	N/A	25.0 0.98	24 7/8	8.4 18.5
BP22T115S	115 mm								

Bore Size 110mm – 115mm only available in QMF/QAF Series Housings

BEARING LOADS

Solid-block housed unit bearings are excellent for many applications including those with:

- Heavy radial loads
- Heavy combined radial and thrust loads
- Shock loads
- Harsh contamination conditions
- Low-to-moderate speeds
- The possibility of misalignment

Bearing loads generally come from one of three sources that should all be evaluated and considered when selecting steel housed unit bearings for your application. Contact your Timken engineer for assistance in determining specific application loads and for bearing recommendations.

- Static loads – weights of various components supported by the bearings
- Drive loads – belts, chains or gears that exert forces on the shaft
- Imposed loads – forces generated by equipment operation

Generally, bearing loads are described as being radial (load perpendicular to the axis of the shaft) or axial (load parallel to the axis of the shaft). Axial loads also are referred to as thrust loads. Spherical roller bearings, by design, are very capable of accepting heavy radial loads, even when combined with a thrust load. Timken® Type E housed units are recommended for use in applications when only thrust loads are present or when the thrust component of the load is larger than the radial component. Contact a Timken sales engineer for more information.

To determine the allowable radial load at various RPMs for bearings supporting only radial loads, simply use the charts on pages 36 – 53. For bearings supporting both radial and thrust loads, an equivalent radial load must first be calculated prior to using these tables (see DYNAMIC EQUIVALENT RADIAL LOAD on page 35).

BELT LOADS

V-belt drives are common sources of drive loads. A good approximation of drive load may be calculated from the formula:

$$\text{Drive Load} = (\text{HP} \times 189000) / (\text{Pulley Diameter} \times \text{RPM})$$

$$\text{Drive Load} = (\text{KW} \times 189000) / (\text{Pulley Diameter} \times \text{RPM})$$

LOAD SHARING

In some cases, bearings may share the load unequally, depending on their position in relationship to the load. Use the appropriate formula below to determine the drive load on each bearing:

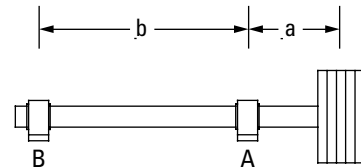

$$\text{Load A} = \text{Drive Load} \times (a + b) / b$$

$$\text{Load B} = \text{Drive Load} \times a / b$$

Fig. 30. Overhung load.

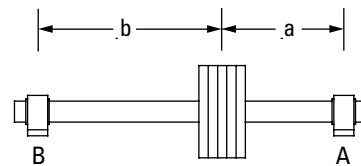

$$\text{Load A} = (\text{Drive Load} \times b) / (a + b)$$

$$\text{Load B} = (\text{Drive Load} \times a) / (a + b)$$

Fig. 31. Load between bearings.

DYNAMIC EQUIVALENT RADIAL LOAD

Bearings that support a combination of radial load and thrust load take an unequal load on one of the rows of rollers. The following formulas and bearing geometry factors are used to convert the independent thrust and radial loads into a single equivalent radial load. The calculated dynamic equivalent radial load (P_r) will have the same effect on bearing life (L_{10}) as a radial load of the same magnitude.

$$P_r = F_r + (Y_1 \times F_a) \text{ when } F_a/F_r \leq e$$

$$P_r = (0.67 \times F_r) + (Y_2 \times F_a) \text{ when } F_a/F_r > e$$

where:

P_r = Dynamic equivalent radial load

F_r = Applied radial load (lbs., N)

F_a = Applied thrust (axial) load (lbs., N)

Y_1 , Y_2 and e are bearing geometry factors shown on pages 36 – 38.

BEARING CALCULATED LIFE

Customers select the bearing life of the bearings in equipment they are building. In the absence of a customer bearing life target, the following may be considered as a guideline:

- If the customer's machinery operates eight hours a day, then use a bearing life target of 20000 to 30000 hours.
- If the customer's machinery operates 24 hours a day, then use a bearing life target of 40000 to 60000 hours.

In addition, a service factor may be used where application conditions are harsh. Extreme environmental conditions or heavy shock or vibration will require the adjustment of load ratings before referring to the L_{10} tables. Please contact your Timken engineer for additional information.

Standard spherical roller bearing life calculation:

$$\text{Bearing life} = L_{10} = (C/P_r)^{10/3} \times (16667/\text{RPM})$$

where:

C = Dynamic capacity
(lbs., N)

P_r = Radial load/dynamic equivalent radial load

RPM = Revolutions per minute

A NOTE ON MINIMUM LOADS

In order for a spherical roller bearing to perform as designed, some radial load should be present. This is particularly true if the bearing is running at high speed. Although it is rarely an issue, as the existing static loads (weights of the combined supported components) usually provide an adequate radial load, there are times when it may be necessary to use a shaft diameter larger than the actual loads require. In these instances, the load becomes a small percentage of the bearing's capacity. Radial loads less than 4 percent of C should be avoided.

BEARING RADIAL AND THRUST FACTORS

TABLE 20. V-LOCK SERIES (TAPERED BORE, C3)

Shaft Dia.	Bearing No.	Dynamic Capacity C	Static Capacity C ₀	Equivalent Radial Load Factors		
				e	Y1	Y2
mm in.		kN lbs.	kN lbs.			
50 1 15/16, 2	22211	140 31400	142 31900	0.23	2.95	4.40
55 2 3/16, 2 1/4	22212	169 38100	174 39000	0.24	2.84	4.23
55 2 3/16, 2 1/4	22213	206 46400	216 48600	0.24	2.79	4.15
60, 65 2 7/16, 2 1/2	22214	213 47800	231 52000	0.23	2.90	4.32
60, 65 2 7/16, 2 1/2	22215	222 49900	240 54100	0.22	3.14	4.67
70, 75 2 11/16, 2 3/4, 2 15/16, 3	22216	254 57200	278 62500	0.22	3.14	4.67
70, 75 2 11/16, 2 3/4, 2 15/16, 3	22217	297 66900	320 71900	0.22	3.07	4.57
80, 85, 90 3 3/16, 3 1/4, 3 7/16, 3 1/2	22219	385 86600	441 99000	0.23	2.88	4.29
80, 85, 90 3 3/16, 3 1/4, 3 7/16, 3 1/2	22220	435 97700	502 113000	0.24	2.85	4.24
100 3 11/16, 3 3/4, 3 15/16, 4	22222	555 125000	653 147000	0.25	2.73	4.06
110 —	22224	647 145000	772 174000	0.25	2.70	4.02
110, 115 4 7/16, 4 1/2	22226	757 170000	945 212000	0.26	2.62	3.90
125, 130 4 15/16, 5	22228	863 194000	1060 237000	0.25	2.67	3.98

TABLE 21. CL SERIES (STRAIGHT BORE, C NORMAL)

Shaft Dia.	Bearing No.	Dynamic Capacity C	Static Capacity C ₀	Equivalent Radial Load Factors		
				e	Y1	Y2
mm in.		kN lbs.	kN lbs.			
35 1 7/16, 1 1/2	22208	104 23400	99.7 22400	0.27	2.47	3.67
40, 45 1 11/16, 1 3/4	22209	109 24500	108 24200	0.26	2.64	3.93
50 1 15/16, 2	22210	117 26300	118 26600	0.24	2.84	4.23
55 2 3/16, 2 1/4	22211	140 31400	142 31900	0.23	2.95	4.40
60, 65 2 7/16, 2 1/2	22213	206 46400	216 48600	0.24	2.79	4.15
70, 75 2 11/16, 2 3/4, 2 15/16, 3	22215	222 49900	240 54100	0.22	3.14	4.67
80, 85, 90 3 3/16, 3 1/4, 3 7/16, 3 1/2	22218	355 79700	388 87200	0.23	2.90	4.31
100 3 15/16, 4	22220	435 97700	502 113000	0.24	2.85	4.24
110, 115 4 7/16, 4 1/2	22222	555 125000	653 147000	0.25	2.73	4.06
125, 130 4 15/16, 5	22226	757 170000	945 212000	0.26	2.62	3.90

TABLE 22. EC SERIES (STRAIGHT BORE, C NORMAL)

Shaft Dia.	Bearing No.	Dynamic Capacity C	Static Capacity C ₀	Equivalent Radial Load Factors		
				e	Y1	Y2
mm in.		kN lbs.	kN lbs.			
35 1 7/16, 1 1/2	22208	104 23400	99.7 22400	0.27	2.47	3.67
40, 45 1 11/16, 1 3/4	22209	109 24500	108 24200	0.26	2.64	3.93
50 1 15/16, 2	22210	117 26300	118 26600	0.24	2.84	4.23
55 2 3/16, 2 1/4	22211	140 31400	142 31900	0.23	2.95	4.40
60, 65 2 7/16, 2 1/2	22213	206 46400	216 48600	0.24	2.79	4.15
70, 75 2 11/16, 2 3/4, 2 15/16, 3	22215	222 49900	240 54100	0.22	3.14	4.67
80, 85, 90 3 3/16, 3 1/4, 3 7/16, 3 1/2	22218	355 79700	388 87200	0.23	2.90	4.31
100 3 11/16, 3 3/4, 3 15/16, 4	22220	435 97700	502 113000	0.24	2.85	4.24
110, 115 4 7/16, 4 1/2	22222	555 125000	653 147000	0.25	2.73	4.06
125, 130 4 15/16, 5	22226	757 170000	945 212000	0.26	2.62	3.90
140, 150 5 7/16, 5 1/2, 5 15/16, 6	23230	1270 286000	1660 372000	0.32	2.08	3.10
170, 180 6 7/16, 6 1/2, 6 15/16, 7	23234	1660 373000	2200 494000	0.33	2.08	3.09

BEARING RADIAL AND THRUST FACTORS – *continued*

TABLE 23. TA/TAA DV/DAA SERIES (TAPERED BORE, C3)

Shaft Dia.	Bearing No.	Dynamic Capacity C	Static Capacity C ₀	Equivalent Radial Load Factors		
				e	Y1	Y2
mm in.		kN lbs.	kN lbs.			
40 1 7/16, 1 1/2	22209	109 24500	108 24200	0.26	2.64	3.93
45 1 11/16, 1 3/4	22210	117 26300	118 26600	0.24	2.84	4.23
50 1 15/16, 2	22211	140 31400	142 31900	0.23	2.95	4.40
55 —	22212	169 38100	174 39000	0.24	2.84	4.23
60 2 3/16, 2 3/16	22213	206 46400	216 48600	0.24	2.79	4.15
65 2 7/16, 2 1/2	22215	222 49900	240 54100	0.22	3.14	4.67
70 2 11/16, 2 3/4	22216	254 57200	278 62500	0.22	3.14	4.67
75 2 15/16, 3	22217	297 66900	320 71900	0.22	3.07	4.57
80 3 3/16, 3 3/16	22218	355 79700	388 87200	0.23	2.90	4.31
85 —	22219	385 86600	441 99000	0.23	2.88	4.29
90 3 7/16, 3 1/2	22220	435 97700	502 113000	0.24	2.85	4.24
100 3 11/16, 3 3/4, 3 15/16, 4	22222	555 125000	653 147000	0.25	2.73	4.06
110 4 3/16, 4 1/4	22224	647 145000	772 174000	0.25	2.70	4.02
115 4 7/16, 4 1/2	22226	757 170000	945 212000	0.26	2.62	3.90
125 4 15/16, 5	22228	863 194000	1060 237000	0.25	2.67	3.98
135, 140 5 3/8, 5 7/16, 5 1/2	23132	1160 261000	1580 355000	0.29	2.33	3.46
150 5 13/16, 5 7/8, 5 15/16, 6	23134	1220 274000	1710 384000	0.28	2.39	3.55
160 6 3/16, 6 3/8, 6 7/16, 6 1/2	23136	1410 317000	2000 450000	0.29	2.32	3.45
170 6 13/16, 6 7/8, 6 15/16, 7	23138	1630 366000	2340 526000	0.30	2.26	3.36
180 7 1/8, 7 3/16, 7 1/4	23140	1660 373000	2290 515000	0.31	2.15	3.20
200 7 13/16, 7 7/8, 7 15/16, 8	23144	1940 436000	2740 616000	0.31	2.17	3.24
220 8 7/16, 8 1/2, 8 15/16, 9	23148	2200 495000	3180 715000	0.30	2.28	3.40
240 9 7/16, 9 1/2	23152	2440 549000	3910 879000	0.30	2.23	3.31
260 9 15/16, 10, 10 7/16, 10 1/2	23156	2530 569000	4140 931000	0.30	2.26	3.36
280 10 15/16, 11	23160	3070 690000	5110 1149000	0.30	2.25	3.35
300 11 7/16, 11 1/2, 11 15/16, 12	23164	3650 821000	5930 1333000	0.31	2.14	3.19
320 12 7/16, 12 1/2	23168	4110 924000	6830 1535000	0.30	2.22	3.30
340 12 15/16, 13, 13 7/16, 13 1/2	23172	4250 955000	7280 1637000	0.29	2.29	3.42
360 13 15/16, 14	23176	4490 1009000	7580 1704000	0.30	2.28	3.39
380 14 15/16, 15	23180	4770 1072000	8110 1823000	0.29	2.32	3.46

LOAD RATINGS

TABLE 24. V-LOCK SERIES – ALLOWABLE RADIAL LOAD (kN/LBS.) AT VARIOUS RPM⁽¹⁾

Shaft Diameter	Bearing No.	C	L ₁₀ Life	Speed ⁽²⁾																
				RPM																
mm in.		kN lbs.		50	100	200	500	1000	1200	1500	1800	2100	2400	2700	3000	3200	3500 ⁽¹⁾			
50 1 15/16, 2	22211	140 31400	10000	50.3 11319	40.9 9194	33.2 7468	25.2 5673	20.5 4608	19.4 4362	18.1 4080	17.2 3863	16.4 3688	15.8 3543	15.2 3420	14.7 3314	14.5 3250	14.1 3164			
			30000	36.2 8141	29.4 6612	23.9 5371	18.1 4080	14.7 3314	14.0 3138	13.1 2934	12.4 2778	11.8 2653	11.3 2549	10.9 2460	10.6 2383	10.4 2338	10.4 2338	10.4 2338	10.1 2276	
			40000	33.2 7468	27.0 6066	21.9 4927	16.6 3743	13.5 3040	12.8 2878	12.0 2692	11.3 2549	10.8 2433	10.4 2338	10.4 2338	10.0 2257	9.7 2186	9.7 2186	9.5 2144	9.5 2144	9.3 2088
			60000	29.4 6612	23.9 5371	19.4 4362	14.7 3314	12.0 2692	11.3 2549	10.6 2383	10.0 2257	9.6 2155	9.2 2070	9.2 2070	8.9 1998	8.6 1936	8.6 1899	8.4 1899	8.4 1899	8.2 1849
			100000	25.2 5673	20.5 4608	16.6 3743	12.6 2843	10.3 2309	9.7 2186	9.1 2045	8.6 1936	8.2 1849	7.9 1776	7.9 1776	7.6 1714	7.4 1661	7.4 1661	7.2 1629	7.2 1629	7.1 1586
55 2 3/16, 2 1/4	22212	169 38100	10000	61.1 13734	49.6 11155	40.3 9061	30.6 6883	24.9 5591	23.5 5293	22.0 4951	20.8 4687	19.9 4475	19.1 4300	18.5 4150	17.9 4021	17.5 3944	17.1 3839			
			30000	43.9 9878	35.7 8023	29.0 6517	22.0 4951	17.9 4021	16.9 3807	15.8 3561	15.0 3371	14.3 3219	13.8 3092	13.3 2985	12.9 2892	12.9 2892	12.6 2837	12.3 2761		
			40000	40.3 9061	32.7 7360	26.6 5978	20.2 4541	16.4 3689	15.5 3492	14.5 3266	13.8 3092	13.1 2953	12.6 2837	12.6 2837	12.2 2738	11.8 2653	11.8 2653	11.6 2602	11.3 2533	
			60000	35.7 8023	29.0 6517	23.5 5293	17.9 4021	14.5 3266	13.8 3092	12.9 2892	12.2 2738	11.6 2614	11.2 2512	11.2 2512	10.8 2425	10.4 2349	10.4 2349	10.2 2304	10.0 2243	
			100000	30.6 6883	24.9 5591	20.2 4541	15.3 3450	12.5 2802	11.8 2653	11.0 2481	10.4 2349	10.0 2243	9.6 2155	9.6 2155	9.3 2080	9.0 2015	9.0 2015	8.8 1977	8.6 1924	
55 2 3/16, 2 1/4	22213	206 46400	10000	74.4 16726	60.4 13585	49.1 11035	37.3 8383	30.3 6809	28.7 6446	26.8 6029	25.4 5708	24.2 5450	23.3 5236	22.5 5054	21.8 4897	21.4 4803	20.8 4676			
			30000	53.5 12030	43.5 9771	35.3 7937	26.8 6029	21.8 4897	20.6 4636	19.3 4336	18.3 4105	17.4 3920	16.8 3766	16.2 3635	15.7 3522	15.4 3455	15.4 3455	15.0 3363		
			40000	49.1 11035	39.9 8963	32.4 7280	24.6 5531	20.0 4492	18.9 4253	17.7 3978	16.8 3766	16.0 3596	15.4 3455	14.8 3335	14.4 3231	14.4 3231	14.1 3169	13.7 3085		
			60000	43.5 9771	35.3 7937	28.7 6446	21.8 4897	17.7 3978	16.8 3766	15.7 3522	14.8 3335	14.2 3184	13.6 3059	13.6 3059	13.1 2953	12.7 2861	12.7 2861	12.5 2806	12.2 2732	
			100000	37.3 8383	30.3 6809	24.6 5531	18.7 4201	15.2 3413	14.4 3231	13.4 3022	12.7 2861	12.2 2732	11.7 2624	11.7 2624	11.3 2533	10.9 2454	10.9 2454	10.7 2407	10.4 2343	
60, 65 2 7/16, 2 1/2	22214	213 47800	10000	76.6 17230	62.3 13995	50.6 11368	38.4 8636	31.2 7014	29.5 6641	27.6 6211	26.2 5880	25.0 5615	24.0 5394	23.2 5207	22.4 5045	22.0 4948				
			30000	55.1 12392	44.8 10066	36.4 8176	27.6 6211	22.4 5045	21.2 4776	19.9 4467	18.8 4229	18.0 4038	18.0 4038	17.3 3880	16.7 3745	16.1 3628	15.8 3559			
			40000	50.6 11368	41.1 9234	33.4 7500	25.3 5697	20.6 4628	19.5 4381	18.2 4098	17.3 3880	16.5 3704	15.8 3559	15.3 3435	14.8 3328	14.8 3328	14.5 3265			
			60000	44.8 10066	36.4 8176	29.5 6641	22.4 5045	18.2 4098	17.3 3880	16.1 3628	15.3 3435	14.6 3280	14.0 3151	14.0 3151	13.5 3042	13.1 2947	12.9 2891			
			100000	38.4 8636	31.2 7014	25.3 5697	19.3 4328	15.6 3515	14.8 3328	13.8 3113	13.1 2947	12.5 2814	12.0 2610	12.0 2610	11.6 2528	11.2 2480	11.0 2480			

⁽¹⁾Speeds referenced here may be higher than speed rating for seals. Please refer to the charts on pages 56 – 58.

Continued on next page.

⁽²⁾For speeds greater than thermal reference speed, contact your Timken engineer.

LOAD RATINGS – continued

TABLE 25. V-LOCK SERIES – ALLOWABLE RADIAL LOAD (kN/LBS.) AT VARIOUS RPM⁽¹⁾

Shaft Diameter	Bearing No.	C	L ₁₀ Life	Speed ⁽²⁾												
				RPM												
mm in.		kN lbs.		50	100	200	500	1000	1200	1500	1800	2100	2400	2700 ⁽¹⁾	3000 ⁽¹⁾	3200 ⁽¹⁾
60, 65 2 1/16, 2 1/2	22215	222 49900	10000	80.0 17987	65.0 14610	52.8 11867	40.1 9015	32.6 7322	30.8 6933	28.8 6484	27.3 6139	26.1 5861	25.0 5631	24.2 5436	23.4 5266	23.0 5166
			30000	57.5 12937	46.7 10508	38.0 8535	28.8 6484	23.4 5266	22.2 4986	20.7 4663	19.6 4415	18.8 4216	18.0 4050	17.4 3909	16.8 3788	16.5 3715
			40000	52.8 11867	42.9 9639	34.8 7829	26.5 5948	21.5 4831	20.3 4574	19.0 4278	18.0 4050	17.2 3867	16.5 3715	16.0 3586	15.5 3475	15.2 3408
			60000	46.7 10508	38.0 8535	30.8 6933	23.4 5266	19.0 4278	18.0 4050	16.8 3788	16.0 3586	15.2 3424	14.6 3290	14.1 3175	13.7 3077	13.4 3018
			100000	40.1 9015	32.6 7322	26.5 5948	20.1 4518	16.3 3670	15.5 3475	14.5 3250	13.7 3077	13.1 2938	12.6 2822	12.1 2724	11.7 2639	11.5 2589
70, 75 2 1/16, 2 3/4, 2 15/16, 3	22216	254 57200	10000	91.7 20619	74.5 16748	60.5 13603	46.0 10334	37.3 8394	35.4 7947	33.1 7432	31.3 7037	29.9 6719	28.7 6455	27.7 6231	26.9 6037	
			30000	66.0 14829	53.6 12045	43.5 9784	33.1 7432	26.9 6037	25.4 5716	23.8 5346	22.5 5061	21.5 4832	20.7 4643	19.9 4481	19.3 4342	
			40000	60.5 13603	49.1 11049	39.9 8975	30.3 6818	24.6 5538	23.3 5243	21.8 4904	20.7 4643	19.7 4433	18.9 4259	18.3 4111	17.7 3983	
			60000	53.6 12045	43.5 9784	35.4 7947	26.9 6037	21.8 4904	20.7 4643	19.3 4342	18.3 4111	17.5 3925	16.8 3771	16.2 3640	15.7 3527	
			100000	46.0 10334	37.3 8394	30.3 6818	23.0 5179	18.7 4207	17.7 3983	16.6 3725	15.7 3527	15.0 3367	14.4 3235	13.9 3123	13.5 3026	
70, 75 2 1/16, 2 3/4, 2 15/16, 3	22217	297 66900	10000	107.3 24115	87.1 19588	70.8 15910	53.8 12086	43.7 9817	41.3 9295	38.7 8693	36.6 8230	35.0 7858	33.6 7550	32.4 7287		
			30000	77.1 17344	62.7 14088	50.9 11443	38.7 8693	31.4 7061	29.7 6685	27.8 6252	26.3 5919	25.1 5652	24.2 5430	23.3 5241		
			40000	70.8 15910	57.5 12923	46.7 10497	35.5 7974	28.8 6477	27.3 6132	25.5 5735	24.2 5430	23.1 5184	22.2 4981	21.4 4808		
			60000	62.7 14088	50.9 11443	41.3 9295	31.4 7061	25.5 5735	24.2 5430	22.6 5078	21.4 4808	20.4 4591	19.6 4410	18.9 4257		
			100000	53.8 12086	43.7 9817	35.5 7974	26.9 6057	21.9 4920	20.7 4658	19.4 4357	18.3 4125	17.5 3938	16.8 3784	16.2 3652		
80, 85, 90 3 3/16, 3 1/4, 3 1/2	22219	385 86600	10000	138.9 31216	112.8 25356	91.6 20595	69.6 15645	56.5 12708	53.5 12032	50.1 11252	47.4 10654	45.2 10172	43.5 9773	42.0 9433		
			30000	99.9 22452	81.1 18236	65.9 14813	50.1 11252	40.7 9140	38.5 8653	36.0 8093	34.1 7662	32.5 7316	31.3 7029	30.2 6785		
			40000	91.6 20595	74.4 16729	60.4 13588	45.9 10322	37.3 8384	35.3 7938	33.0 7424	31.3 7029	29.9 6711	28.7 6448	27.7 6224		
			60000	81.1 18236	65.9 14813	53.5 12032	40.7 9140	33.0 7424	31.3 7029	29.2 6574	27.7 6224	26.4 5942	25.4 5709	24.5 5511		
			100000	69.6 15645	56.5 12708	45.9 10322	34.9 7841	28.3 6369	26.8 6030	25.1 5640	23.7 5339	22.7 5098	21.8 4898	21.0 4728		

⁽¹⁾Speeds referenced here may be higher than speed rating for seals. Please refer to the charts on pages 56 – 58.

⁽²⁾For speeds greater than thermal reference speed, contact your Timken engineer.

Continued on next page.

Continued from previous page.

Shaft Diameter	Bearing No.	C	L ₁₀ Life	Speed ⁽²⁾												
				RPM												
mm in.		kN lbs.		50	100	200	500	1000	1200	1500	1800 ⁽¹⁾	2100 ⁽¹⁾	2400 ⁽¹⁾	2700 ⁽¹⁾		
80, 85, 90 3 3/16, 3 1/4, 3 7/16, 3 1/2	22220	435 97700	10000	156.7 35218	127.2 28606	103.4 23235	78.5 17651	63.8 14337	60.4 13574	56.5 12695	53.5 12019	51.0 11476	49.0 11025	47.3 10642		
			30000	112.7 25329	91.5 20574	74.3 16711	56.5 12695	45.9 10311	43.4 9762	40.6 9130	38.5 8644	36.7 8254	35.3 7930	34.0 7654		
			40000	103.4 23235	84.0 18873	68.2 15329	51.8 11645	42.1 9459	39.8 8955	37.3 8375	35.3 7930	33.7 7571	32.4 7274	31.2 7021		
			60000	91.5 20574	74.3 16711	60.4 13574	45.9 10311	37.3 8375	35.3 7930	33.0 7416	31.2 7021	29.8 6704	28.7 6441	27.7 6217		
			100000	78.5 17651	63.8 14337	51.8 11645	39.3 8846	32.0 7185	30.3 6803	28.3 6362	26.8 6024	25.6 5752	24.6 5526	23.7 5334		
100 3 11/16, 3 3/4, 3 15/16, 4	22222	555 125000	10000	200.4 45058	162.8 36599	132.2 29727	100.5 22583	81.6 18343	77.3 17367	72.2 16242	68.4 15377	65.3 14683	62.7 14106			
			30000	144.2 32407	117.1 26323	95.1 21381	72.2 16242	58.7 13193	55.6 12490	52.0 11682	49.2 11060	47.0 10560	45.1 10145			
			40000	132.2 29727	107.4 24146	87.2 19613	66.3 14899	53.8 12102	51.0 11458	47.7 10716	45.1 10145	43.1 9687	41.4 9306			
			60000	117.1 26323	95.1 21381	77.3 17367	58.7 13193	47.7 10716	45.1 10145	42.2 9488	40.0 8983	38.2 8577	36.7 8241			
			100000	100.5 22583	81.6 18343	66.3 14899	50.3 11318	40.9 9193	38.7 8704	36.2 8140	34.3 7707	32.7 7359	31.4 7070			
110 —	22224	647 145000	10000	232.5 52268	188.8 42455	153.4 34484	116.5 26196	94.6 21278	89.6 20145	83.8 18841	79.3 17838	75.8 17032	72.8 16363			
			30000	167.2 37592	135.8 30534	110.3 24802	83.8 18841	68.1 15303	64.5 14489	60.3 13551	57.1 12829	54.5 12250	52.4 11769			
			40000	153.4 34484	124.6 28010	101.2 22751	76.9 17283	62.4 14038	59.1 13291	55.3 12430	52.4 11769	50.0 11237	48.0 10796			
			60000	135.8 30534	110.3 24802	89.6 20145	68.1 15303	55.3 12430	52.4 11769	49.0 11007	46.4 10421	44.3 9950	42.5 9559			
			100000	116.5 26196	94.6 21278	76.9 17283	58.4 13129	47.4 10664	44.9 10097	42.0 9443	39.8 8940	38.0 8536	36.5 8201			

⁽¹⁾Speeds referenced here may be higher than speed rating for seals. Please refer to the charts on pages 56 – 58.

⁽²⁾For speeds greater than thermal reference speed, contact your Timken engineer.

Continued on next page.

LOAD RATINGS – *continued*

TABLE 25. V-LOCK SERIES – ALLOWABLE RADIAL LOAD (kN/LBS.) AT VARIOUS RPM⁽¹⁾

Shaft Diameter	Bearing No.	C	L ₁₀ Life	Speed ⁽²⁾								
				RPM								
mm in.		kN lbs.		50	100	200	500	1000	1200 ⁽¹⁾	1500 ⁽¹⁾	1800 ⁽¹⁾	2100 ⁽¹⁾
110, 115 4 7/16, 4 1/2	22226	757 170000	10000	272.6 61279	221.4 49774	179.8 40429	136.6 30712	111.0 24946	105.1 23618	98.3 22089	93.0 20913	88.8 19968
			30000	196.1 44074	159.2 35799	129.3 29078	98.3 22089	79.8 17942	75.6 16987	70.7 15887	66.9 15041	63.9 14362
			40000	179.8 40429	146.1 32839	118.6 26673	90.1 20263	73.2 16458	69.3 15582	64.8 14573	61.4 13798	58.6 13174
			60000	159.2 35799	129.3 29078	105.1 23618	79.8 17942	64.8 14573	61.4 13798	57.4 12904	54.3 12217	51.9 11665
			100000	136.6 30712	111.0 24946	90.1 20263	68.5 15393	55.6 12503	52.7 11837	49.2 11071	46.6 10482	44.5 10008
							50	100	200	500	1000 ⁽¹⁾	1200 ⁽¹⁾
125, 130 4 15/16, 5	22228	863 194000	10000	311.1 69931	252.7 56801	205.2 46137	155.9 35048	126.6 28468	119.9 26953	112.1 25208	106.2 23866	
			30000	223.7 50296	181.7 40853	147.6 33183	112.1 25208	91.1 20475	86.2 19385	80.6 18130	76.4 17165	
			40000	205.2 46137	166.7 37475	135.4 30439	102.9 23123	83.5 18782	79.1 17782	74.0 16631	70.0 15746	
			60000	181.7 40853	147.6 33183	119.9 26953	91.1 20475	74.0 16631	70.0 15746	65.5 14726	62.0 13942	
			100000	155.9 35048	126.6 28468	102.9 23123	78.1 17566	63.5 14268	60.1 13508	56.2 12634	53.2 11961	

⁽¹⁾Speeds referenced here may be higher than speed rating for seals. Please refer to the charts on pages 56 – 58.

⁽²⁾For speeds greater than thermal reference speed, contact your Timken engineer.

TABLE 26. CL SERIES – ALLOWABLE RADIAL LOAD (kN/LBS.) AT VARIOUS RPM⁽¹⁾

Shaft Diameter	Bearing No.	C	L ₁₀ Life	Speed ⁽²⁾														
				RPM														
mm in.		kN lbs.		50	100	200	500	1000	1200	1500	1800	2100	2400	2700	3000	3200	3500	
35 1 1/16, 1 1/2	22208	104 23400	10000	37.5	30.5	24.8	18.8	15.3	14.5	13.5	12.8	12.2	11.7	11.3	11.0	10.8	10.5	
				8435	6851	5565	4227	3434	3251	3041	2879	2749	2641	2549	2470	2422	2358	
				30000	27.0	21.9	17.8	13.5	11.0	10.4	9.7	9.2	8.8	8.4	8.2	7.9	7.7	7.5
				6067	4928	4002	3041	2470	2338	2187	2070	1977	1899	1833	1776	1742	1696	
				40000	24.8	20.1	16.3	12.4	10.1	9.5	8.9	8.4	8.1	7.7	7.5	7.2	7.1	6.9
				5565	4520	3672	2789	2265	2145	2006	1899	1813	1742	1682	1629	1598	1556	
40, 45 1 1/16, 1 3/4	22209	109 24500	10000	39.3	31.9	25.9	19.7	16.0	15.1	14.2	13.4	12.8	12.3	11.9	11.5	11.3	11.0	
				8831	7173	5827	4426	3595	3404	3183	3014	2878	2765	2669	2586	2536	2469	
				30000	28.3	22.9	18.6	14.2	11.5	10.9	10.2	9.6	9.2	8.8	8.5	8.3	8.1	7.9
				6352	5159	4191	3183	2586	2448	2290	2168	2070	1988	1919	1860	1824	1776	
				40000	25.9	21.1	17.1	13.0	10.6	10.0	9.3	8.8	8.4	8.1	7.8	7.6	7.4	7.2
				5827	4733	3844	2920	2372	2246	2100	1988	1899	1824	1761	1706	1673	1629	
50 1 15/16, 2	22210	117 26300	10000	42.2	34.3	27.8	21.1	17.2	16.3	15.2	14.4	13.7	13.2	12.7	12.3	12.1	11.8	
				9480	7700	6255	4751	3859	3654	3417	3235	3089	2968	2865	2776	2723	2650	
				30000	30.3	24.6	20.0	15.2	12.3	11.7	10.9	10.4	9.9	9.5	9.2	8.9	8.7	8.5
				6818	5538	4498	3417	2776	2628	2458	2327	2222	2135	2060	1996	1958	1906	
				40000	27.8	22.6	18.4	13.9	11.3	10.7	10.0	9.5	9.1	8.7	8.4	8.1	8.0	7.8
				6255	5080	4127	3135	2546	2411	2255	2135	2038	1958	1890	1831	1796	1749	
55 2 3/16, 2 1/4	22211	140 31400	10000	44.2	36.0	29.0	22.0	18.0	17.0	16.0	15.0	14.0	13.0	12.0	11.0	10.0	9.0	
				4426	3595	2920	2218	1802	1706	1595	1511	1442	1386	1338	1296	1271	1237	
				30000	33.2	27.0	21.9	16.6	13.5	12.8	12.0	11.3	10.8	10.4	10.0	9.7	9.5	9.3
				7468	6066	4927	3743	3040	2878	2692	2549	2433	2338	2257	2186	2144	2088	
				40000	29.4	23.9	19.4	14.7	12.0	11.3	10.6	10.0	9.6	9.2	8.9	8.6	8.4	8.2
				6612	5371	4362	3314	2692	2549	2383	2257	2155	2070	1998	1936	1899	1849	
60, 65 2 1/16, 2 1/2	22213	206 46400	10000	50.3	40.9	33.2	25.2	20.5	19.4	18.1	17.2	16.4	15.8	15.2	14.7	14.5	14.1	
				11319	9194	7468	5673	4608	4362	4080	3863	3688	3543	3420	3314	3250	3164	
				30000	36.2	29.4	23.9	18.1	14.7	14.0	13.1	12.4	11.8	11.3	10.9	10.6	10.4	10.1
				8141	6612	5371	4080	3314	3138	2934	2778	2653	2549	2460	2383	2338	2276	
				40000	33.2	27.0	21.9	16.6	13.5	12.8	12.0	11.3	10.8	10.4	10.0	9.7	9.5	9.3
				7468	6066	4927	3743	3040	2878	2692	2549	2433	2338	2257	2186	2144	2088	
60, 65 2 3/16, 2 1/2	22213	206 46400	10000	25.2	20.5	16.6	12.6	10.3	9.7	9.1	8.6	8.2	7.9	7.6	7.4	7.2	7.1	
				5673	4608	3743	2843	2309	2186	2045	1936	1849	1776	1714	1661	1629	1586	
				30000	25.2	20.5	16.6	12.6	10.3	9.7	9.1	8.6	8.2	7.9	7.6	7.4	7.2	7.1
				5673	4608	3743	2843	2309	2186	2045	1936	1849	1776	1714	1661	1629	1586	
				40000	25.2	20.5	16.6	12.6	10.3	9.7	9.1	8.6	8.2	7.9	7.6	7.4	7.2	7.1
				5673	4608	3743	2843	2309	2186	2045	1936	1849	1776	1714	1661	1629	1586	

⁽¹⁾Speeds referenced here may be higher than speed rating for seals. Please refer to the charts on pages 56 – 58.

Continued on next page.

⁽²⁾For speeds greater than thermal reference speed, contact your Timken engineer.

LOAD RATINGS – continued

TABLE 26. CL SERIES – ALLOWABLE RADIAL LOAD (kN/LBS.) AT VARIOUS RPM⁽¹⁾

Shaft Diameter	Bearing No.	C	L ₁₀ Life	Speed ⁽²⁾													
				RPM													
mm in.		kN lbs.		50	100	200	500	1000	1200	1500	1800	2100	2400	2700 ⁽¹⁾	3000 ⁽¹⁾	3200 ⁽¹⁾	
70, 75 2 1/16, 2 3/4, 2 15/16, 3	22215	220 49900	10000	80.0 17987	65.0 14610	52.8 11867	40.1 9015	32.6 7322	30.8 6933	28.8 6484	27.3 6139	26.1 5861	25.0 5631	24.2 5436	23.4 5266	23.0 5166	
			30000	57.5 12937	46.7 10508	38.0 8535	28.8 6484	23.4 5266	22.2 4986	20.7 4663	19.6 4415	18.8 4216	18.0 4050	17.4 3909	16.8 3788	16.5 3715	
			40000	52.8 11867	42.9 9639	34.8 7829	26.5 5948	21.5 4831	20.3 4574	19.0 4278	18.0 4050	17.2 3867	16.5 3715	16.0 3586	15.5 3475	15.2 3408	
			60000	46.7 10508	38.0 8535	30.8 6933	23.4 5266	19.0 4278	18.0 4050	16.8 3788	16.0 3586	15.2 3424	14.6 3290	14.1 3175	13.7 3077	13.4 3018	
			100000	40.1 9015	32.6 7322	26.5 5948	20.1 4518	16.3 3670	15.5 3475	14.5 3250	13.7 3077	13.1 2938	12.6 2822	12.1 2724	11.7 2639	11.5 2589	
						50	100	200	500	1000	1200	1500	1800	2100 ⁽¹⁾	2400 ⁽¹⁾	2700 ⁽¹⁾	
80, 85, 90 3 3/16, 3 1/4, 3 1/2, 3 1/2	22218	355 79700	10000	127.8 28729	103.8 23335	84.3 18954	64.0 14399	52.0 11695	49.3 11073	46.1 10356	43.6 9805	41.6 9362	40.0 8994	38.6 8682			
			30000	91.9 20663	74.7 16783	60.6 13632	46.1 10356	37.4 8412	35.4 7964	33.1 7448	31.4 7052	29.9 6733	28.8 6469	27.8 6244			
			40000	84.3 18954	68.5 15396	55.6 12505	42.3 9500	34.3 7716	32.5 7305	30.4 6832	28.8 6469	27.5 6176	26.4 5934	25.5 5728			
			60000	74.7 16783	60.6 13632	49.3 11073	37.4 8412	30.4 6832	28.8 6469	26.9 6050	25.5 5728	24.3 5469	23.4 5254	22.6 5072			
			100000	64.0 14399	52.0 11695	42.3 9500	32.1 7216	26.1 5862	24.7 5550	23.1 5190	21.9 4914	20.9 4692	20.1 4508	19.4 4351			
						50	100	200	500	1000	1200	1500	1800 ⁽¹⁾	2100 ⁽¹⁾	2400 ⁽¹⁾	2700 ⁽¹⁾	
100 3 15/16, 4	22220	435 97700	10000	156.7 35218	127.2 28606	103.4 23235	78.5 17651	63.8 14337	60.4 13574	56.5 12695	53.5 12019	51.0 11476	49.0 11025	47.3 10642			
			30000	112.7 25329	91.5 20574	74.3 16711	56.5 12695	45.9 10311	43.4 9762	40.6 9130	38.5 8644	36.7 8254	35.3 7930	34.0 7654			
			40000	103.4 23235	84.0 18873	68.2 15329	51.8 11645	42.1 9459	39.8 8955	37.3 8375	35.3 7930	33.7 7571	32.4 7274	31.2 7021	30.7 7021		
			60000	91.5 20574	74.3 16711	60.4 13574	45.9 10311	37.3 8375	35.3 7930	33.0 7416	31.2 7021	29.8 6704	28.7 6441	27.7 6217			
			100000	78.5 17651	63.8 14337	51.8 11645	39.3 8846	32.0 7185	30.3 6803	28.3 6362	26.8 6024	25.6 5752	24.6 5526	23.7 5334			
						50	100	200	500	1000	1200	1500 ⁽¹⁾	1800 ⁽¹⁾	2100 ⁽¹⁾	2400 ⁽¹⁾		
110, 115 4 7/16, 4 1/2	22222	555 125000	10000	200.4 45058	162.8 36599	132.2 29727	100.5 22583	81.6 18343	77.3 17367	72.2 16242	68.4 15377	65.3 14683	62.7 14106				
			30000	144.2 32407	117.1 26323	95.1 21381	72.2 16242	58.7 13193	55.6 12490	52.0 11682	49.2 11060	47.0 10560	45.1 10145				
			40000	132.2 29727	107.4 24146	87.2 19613	66.3 14899	53.8 12102	51.0 11458	47.7 10716	45.1 10145	43.1 9687	41.4 9306				
			60000	117.1 26323	95.1 21381	77.3 17367	58.7 13193	47.7 10716	45.1 10145	42.2 9488	40.0 8983	38.2 8577	36.7 8241				
			100000	100.5 22583	81.6 18343	66.3 14899	50.3 11318	40.9 9193	38.7 8704	36.2 8140	34.3 7707	32.7 7359	31.4 7070				
						50	100	200	500	1000	1200 ⁽¹⁾	1500 ⁽¹⁾	1800 ⁽¹⁾	2100 ⁽¹⁾			
125, 130 4 15/16, 5	22226	757 170000	10000	272.6 61279	221.4 49774	179.8 40429	136.6 30712	111.0 24946	105.1 23618	98.3 22089	93.0 20913	88.8 19968					
			30000	196.1 44074	159.2 35799	129.3 29078	98.3 22089	79.8 17942	75.6 16987	70.7 15887	66.9 15041	63.9 14362					
			40000	179.8 40429	146.1 32839	118.6 26673	90.1 20263	73.2 16458	69.3 15582	64.8 14573	61.4 13798	58.6 13174					
			60000	159.2 35799	129.3 29078	105.1 23618	79.8 17942	64.8 14573	61.4 13798	57.4 12904	54.3 12217	51.9 11665					
			100000	136.6 30712	111.0 24946	90.1 20263	68.5 15393	55.6 12503	52.7 11837	49.2 11071	46.6 10482	44.5 10008					
						50	100	200	500	1000	1200 ⁽¹⁾	1500 ⁽¹⁾	1800 ⁽¹⁾	2100 ⁽¹⁾			

⁽¹⁾Speeds referenced here may be higher than speed rating for seals. Please refer to the charts on pages 56 – 58.

⁽²⁾For speeds greater than thermal reference speed, contact your Timken engineer.

TABLE 27. EC SERIES – ALLOWABLE RADIAL LOAD (kN/LBS.) AT VARIOUS RPM⁽¹⁾

Shaft Diameter	Bearing No.	C	L ₁₀ Life	Speed ⁽²⁾													
				RPM													
mm in.		kN lbs.		50	100	200	500	1000	1200	1500	1800	2100	2400	2700	3000	3200	3500
35 1 1/16, 1 1/2	22208	104 23400	10000	37.5 8435	30.5 6851	24.8 5565	18.8 4227	15.3 3434	14.5 3251	13.5 3041	12.8 2879	12.2 2749	11.7 2641	11.3 2549	11.0 2470	10.8 2422	10.5 2358
			30000	27.0 6067	21.9 4928	17.8 4002	13.5 3041	11.0 2470	10.4 2338	9.7 2187	9.2 2070	8.8 1977	8.4 1899	8.2 1833	7.9 1776	7.7 1742	7.5 1696
			40000	24.8 5565	20.1 4520	16.3 3672	12.4 2789	10.1 2265	9.5 2145	8.9 2006	8.4 1899	8.1 1813	7.7 1742	7.5 1682	7.2 1629	7.1 1598	6.9 1556
			60000	21.9 4928	17.8 4002	14.5 3251	11.0 2470	8.9 2006	8.4 1899	7.9 1776	7.5 1682	7.1 1606	6.9 1543	6.6 1489	6.4 1443	6.3 1415	6.1 1378
			100000	18.8 4227	15.3 3434	12.4 2789	9.4 2119	7.7 1721	7.2 1629	6.8 1524	6.4 1443	6.1 1378	5.9 1323	5.7 1278	5.5 1238	5.4 1214	5.3 1182
40, 45 1 1/16, 1 3/4	22209	109 24500	10000	39.3 8831	31.9 7173	25.9 5827	19.7 4426	16.0 3595	15.1 3404	14.2 3183	13.4 3014	12.8 2878	12.3 2765	11.9 2669	11.5 2586	11.3 2536	11.0 2469
			30000	28.3 6352	22.9 5159	18.6 4191	14.2 3183	11.5 2586	10.9 2448	10.2 2290	9.6 2168	9.2 2070	8.8 1988	8.5 1919	8.3 1860	8.1 1824	7.9 1776
			40000	25.9 5827	21.1 4733	17.1 3844	13.0 2920	10.6 2372	10.0 2246	9.3 2100	8.8 1988	8.4 1899	8.1 1824	7.8 1761	7.6 1706	7.4 1673	7.2 1629
			60000	22.9 5159	18.6 4191	15.1 3404	11.5 2586	9.3 2100	8.8 1988	8.3 1860	7.8 1761	7.5 1681	7.2 1615	6.9 1559	6.7 1511	6.6 1482	6.4 1442
			100000	19.7 4426	16.0 3595	13.0 2920	9.9 2218	8.0 1802	7.6 1706	7.1 1595	6.7 1511	6.4 1442	6.2 1386	6.0 1338	5.8 1296	5.7 1271	5.5 1237
50 1 1/16, 2	22210	117 26300	10000	42.2 9480	34.3 7700	27.8 6255	21.1 4751	17.2 3859	16.3 3654	15.2 3417	14.4 3235	13.7 3089	13.2 2968	12.7 2865	12.3 2776	12.1 2723	11.8 2650
			30000	30.3 6818	24.6 5538	20.0 4498	15.2 3417	12.3 2776	11.7 2628	10.9 2458	10.4 2327	9.9 2222	9.5 2135	9.2 2060	8.9 1996	8.7 1958	8.5 1906
			40000	27.8 6255	22.6 5080	18.4 4127	13.9 3135	11.3 2546	10.7 2411	10.0 2255	9.5 2135	9.1 2038	8.7 1958	8.4 1890	8.1 1831	8.0 1796	7.8 1749
			60000	24.6 5538	20.0 4498	16.3 3654	12.3 2776	10.0 2255	9.5 2135	8.9 1996	8.4 1890	8.0 1805	7.7 1734	7.4 1674	7.2 1622	7.1 1590	6.9 1548
			100000	21.1 4751	17.2 3859	13.9 3135	10.6 2381	8.6 1934	8.1 1831	7.6 1713	7.2 1622	6.9 1548	6.6 1487	6.4 1436	6.2 1391	6.1 1364	5.9 1328
55 2 3/16, 2 1/4	22211	140 31400	10000	50.3 11319	40.9 9194	33.2 7468	25.2 5673	20.5 4608	19.4 4362	18.1 4080	17.2 3863	16.4 3688	15.8 3543	15.2 3420	14.7 3314	14.5 3250	14.1 3164
			30000	36.2 8141	29.4 6612	23.9 5371	18.1 4080	14.7 3314	14.0 3138	13.1 2934	12.4 2778	11.8 2653	11.3 2549	10.9 2460	10.6 2383	10.4 2338	10.1 2276
			40000	33.2 7468	27.0 6066	21.9 4927	16.6 3743	13.5 3040	12.8 2878	12.0 2692	11.3 2549	10.8 2433	10.4 2338	10.0 2257	9.7 2186	9.5 2144	9.3 2088
			60000	29.4 6612	23.9 5371	19.4 4362	14.7 3314	12.0 2692	11.3 2549	10.6 2383	10.0 2257	9.6 2155	9.2 2070	8.9 1998	8.6 1936	8.4 1899	8.2 1849
			100000	25.2 5673	20.5 4608	16.6 3743	12.6 2843	10.3 2309	9.7 2186	9.1 2045	8.6 1936	8.2 1849	7.9 1776	7.6 1714	7.4 1661	7.2 1629	7.1 1586
60, 65 2 1/8, 2 1/2	22213	206 46400	10000	74.4 16726	60.4 13585	49.1 11035	37.3 8383	30.3 6809	28.7 6446	26.8 6029	25.4 5708	24.2 5450	23.3 5236	22.5 5054	21.8 4897	21.4 4803	20.8 4676
			30000	53.5 12030	43.5 9771	35.3 7937	26.8 6029	21.8 4897	20.6 4636	19.3 4336	18.3 4105	17.4 3920	16.8 3766	16.2 3635	15.7 3522	15.4 3455	15.0 3363
			40000	49.1 11035	39.9 8963	32.4 7280	24.6 5531	20.0 4492	18.9 4253	17.7 3978	16.8 3766	16.0 3596	15.4 3455	14.8 3335	14.4 3231	14.1 3169	13.7 3085
			60000	43.5 9771	35.3 7937	28.7 6446	21.8 4897	17.7 3978	16.8 3766	15.7 3522	14.8 3335	14.2 3184	13.6 3059	13.1 2953	12.7 2861	12.5 2806	12.2 2732
			100000	37.3 8383	30.3 6809	24.6 5531	18.7 4201	15.2 3413	14.4 3231	13.4 3022	12.7 2861	12.2 2732	11.7 2624	11.3 2533	10.9 2454	10.7 2407	10.4 2343

⁽¹⁾Speeds referenced here may be higher than speed rating for seals. Please refer to the charts on pages 56 – 58.

⁽²⁾For speeds greater than thermal reference speed, contact your Timken engineer.

Continued on next page.

LOAD RATINGS – Continued from previous page

TABLE 27. EC SERIES – ALLOWABLE RADIAL LOAD (kN/LBS.) AT VARIOUS RPM⁽¹⁾

Shaft Diameter	Bearing No.	C	L ₁₀ Life	Speed ⁽²⁾												
				RPM												
mm in.		kN lbs.		50	100	200	500	1000	1200	1500	1800	2100	2400	2700 ⁽¹⁾	3000 ⁽¹⁾	3200 ⁽¹⁾
70, 75 2 1/16, 2 3/4, 2 15/16, 3	22215	222 49900	10000	80.0 17987	65.0 14610	52.8 11867	40.1 9015	32.6 7322	30.8 6933	28.8 6484	27.3 6139	26.1 5861	25.0 5631	24.2 5436	23.4 5266	23.0 5166
			30000	57.5 12937	46.7 10508	38.0 8535	28.8 6484	23.4 5266	22.2 4986	20.7 4663	19.6 4415	18.8 4216	18.0 4050	17.4 3909	16.8 3788	16.5 3715
			40000	52.8 11867	42.9 9639	34.8 7829	26.5 5948	21.5 4831	20.3 4574	19.0 4278	18.0 4050	17.2 3867	16.5 3715	16.0 3586	15.5 3475	15.2 3408
			60000	46.7 10508	38.0 8535	30.8 6933	23.4 5266	19.0 4278	18.0 4050	16.8 3788	16.0 3586	15.2 3424	14.6 3290	14.1 3175	13.7 3077	13.4 3018
			100000	40.1 9015	32.6 7322	26.5 5948	20.1 4518	16.3 3670	15.5 3475	14.5 3250	13.7 3077	13.1 2938	12.6 2822	12.1 2724	11.7 2639	11.5 2589
						50	100	200	500	1000	1200	1500	1800	2100 ⁽¹⁾	2400 ⁽¹⁾	2700 ⁽¹⁾
80, 85, 90 3 3/16, 3 3/4, 3 7/16, 3 1/2	22218	355 79700	10000	127.8 28729	103.8 23335	84.3 18954	64.0 14399	52.0 11695	49.3 11073	46.1 10356	43.6 9805	41.6 9362	40.0 8994	38.6 8682		
			30000	91.9 20663	74.7 16783	60.6 13632	46.1 10356	37.4 8412	35.4 7964	33.1 7448	31.4 7052	29.9 6733	28.8 6469	27.8 6244		
			40000	84.3 18954	68.5 15396	55.6 12505	42.3 9500	34.3 7716	32.5 7305	30.4 6832	28.8 6469	27.5 6176	26.4 5934	25.5 5728		
			60000	74.7 16783	60.6 13632	49.3 11073	37.4 8412	30.4 6832	28.8 6469	26.9 6050	25.5 5728	24.3 5469	23.4 5254	22.6 5072		
			100000	64.0 14399	52.0 11695	42.3 9500	32.1 7216	26.1 5862	24.7 5550	23.1 5190	21.9 4914	20.9 4692	20.1 4508	19.4 4351		
						50	100	200	500	1000	1200	1500	1800 ⁽¹⁾	2100 ⁽¹⁾	2400 ⁽¹⁾	2700 ⁽¹⁾
100 3 11/16, 3 3/4, 3 15/16, 4	22220	435 97700	10000	156.7 35218	127.2 28606	103.4 23235	78.5 17651	63.8 14337	60.4 13574	56.5 12695	53.5 12019	51.0 11476	49.0 11025	47.3 10642		
			30000	112.7 25329	91.5 20574	74.3 16711	56.5 12695	45.9 10311	43.4 9762	40.6 9130	38.5 8644	36.7 8254	35.3 7930	34.0 7654		
			40000	103.4 23235	84.0 18873	68.2 15329	51.8 11645	42.1 9459	39.8 8955	37.3 8375	35.3 7930	33.7 7571	32.4 7274	31.2 7021		
			60000	91.5 20574	74.3 16711	60.4 13574	45.9 10311	37.3 8375	35.3 7930	33.0 7416	31.2 7021	29.8 6704	28.7 6441	27.7 6217		
			100000	78.5 17651	63.8 14337	51.8 11645	39.3 8846	32.0 7185	30.3 6803	28.3 6362	26.8 6024	25.6 5752	24.6 5526	23.7 5334		
						50	100	200	500	1000	1200	1500 ⁽¹⁾	1800 ⁽¹⁾	2100 ⁽¹⁾	2400 ⁽¹⁾	
110, 115 4 7/16, 4 1/2	22222	555 125000	10000	200.4 45058	162.8 36599	132.2 29727	100.5 22583	81.6 18343	77.3 17367	72.2 16242	68.4 15377	65.3 14683	62.7 14106			
			30000	144.2 32407	117.1 26323	95.1 21381	72.2 16242	58.7 13193	55.6 12490	52.0 11682	49.2 11060	47.0 10560	45.1 10145			
			40000	132.2 29727	107.4 24146	87.2 19613	66.3 14899	53.8 12102	51.0 11458	47.7 10716	45.1 10145	43.1 9687	41.4 9306			
			60000	117.1 26323	95.1 21381	77.3 17367	58.7 13193	47.7 10716	45.1 10145	42.2 9488	40.0 8983	38.2 8577	36.7 8241			
			100000	100.5 22583	81.6 18343	66.3 14899	50.3 11318	40.9 9193	38.7 8704	36.2 8140	34.3 7707	32.7 7359	31.4 7070			
						50	100	200	500	1000	1200 ⁽¹⁾	1500 ⁽¹⁾	1800 ⁽¹⁾	2100 ⁽¹⁾		
125, 130 4 15/16, 5	22226	757 170000	10000	272.6 61279	221.4 49774	179.8 40429	136.6 30712	111.0 24946	105.1 23618	98.3 22089	93.0 20913	88.8 19968				
			30000	196.1 44074	159.2 35799	129.3 29078	98.3 22089	79.8 17942	75.6 16987	70.7 15887	66.9 15041	63.9 14362				
			40000	179.8 40429	146.1 32839	118.6 26673	90.1 20263	73.2 16458	69.3 15582	64.8 14573	61.4 13798	58.6 13174				
			60000	159.2 35799	129.3 29078	105.1 23618	79.8 17942	64.8 14573	61.4 13798	57.4 12904	54.3 12217	51.9 11665				
			100000	136.6 30712	111.0 24946	90.1 20263	68.5 15393	55.6 12503	52.7 11837	49.2 11071	46.6 10482	44.5 10008				
						50	100	200	500	1000	1200 ⁽¹⁾	1500 ⁽¹⁾	1800 ⁽¹⁾	2100 ⁽¹⁾		

⁽¹⁾Speeds referenced here may be higher than speed rating for seals. Please refer to the charts on pages 56 – 58.
⁽²⁾For speeds greater than thermal reference speed, contact your Timken engineer.

Continued on next page.

Continued from previous page.

Shaft Diameter	Bearing No.	C	L ₁₀ Life	Speed ⁽²⁾					
				RPM					
mm in.		kN lbs.		50	100	200	500	1000 ⁽¹⁾	1200 ⁽¹⁾
140, 150 5 7/16, 5 1/2, 5 15/16, 6	23230	1270 286000	10000	458.6 103094	372.5 83738	302.6 68016	229.8 51669	186.7 41968	176.8 39735
			30000	329.8 74147	267.9 60226	217.6 48919	165.3 37162	134.3 30185	127.1 28578
			40000	302.6 68016	245.8 55247	199.6 44874	151.6 34089	123.2 27689	116.6 26215
			60000	267.9 60226	217.6 48919	176.8 39735	134.3 30185	109.1 24518	103.3 23213
			100000	229.8 51669	186.7 41968	151.6 34089	115.2 25896	93.6 21034	88.6 19914
							50	100	200
170, 180 6 7/16, 6 1/2, 6 15/16, 7	23234	1660 373000	10000	598.1 134454	485.8 109211	394.6 88707	299.8 67387	243.5 54735	
			30000	430.2 96703	349.4 78547	283.8 63800	215.6 48466	175.1 39367	
			40000	394.6 88707	320.5 72052	260.3 58525	197.8 44459	160.6 36112	
			60000	349.4 78547	283.8 63800	230.5 51822	175.1 39367	142.2 31976	
			100000	299.8 67387	243.5 54735	197.8 44459	150.2 33773	122.0 27433	
							50	100	200

⁽¹⁾Speeds referenced here may be higher than speed rating for seals. Please refer to the charts on pages 56 – 58.

⁽²⁾For speeds greater than thermal reference speed, contact your Timken engineer.

LOAD RATINGS – continued

TABLE 28. TA - ALLOWABLE RADIAL LOAD (kN/LBS.) AT VARIOUS RPM⁽¹⁾

Shaft Diameter	Bearing No.	C	L ₁₀ Life	Speed ⁽²⁾													
				RPM													
mm in.		kN lbs.		50	100	200	500	1000	1200	1500	1800	2100	2400	2700	3000	3200	3500
40 1 7/16, 1 1/2	22209	109 24500	10000	39.3 8831	31.9 7173	25.9 5827	19.7 4426	16.0 3595	15.1 3404	14.2 3183	13.4 3014	12.8 2878	12.3 2765	11.9 2669	11.5 2586	11.3 2536	11.0 2469
			30000	28.3 6352	22.9 5159	18.6 4191	14.2 3183	11.5 2586	10.9 2448	10.2 2290	9.6 2168	9.2 2070	8.8 1988	8.5 1919	8.3 1860	8.1 1824	7.9 1776
			40000	25.9 5827	21.1 4733	17.1 3844	13.0 2920	10.6 2372	10.0 2246	9.3 2100	8.8 1988	8.4 1899	8.1 1824	7.8 1761	7.6 1706	7.4 1673	7.2 1629
			60000	22.9 5159	18.6 4191	15.1 3404	11.5 2586	9.3 2100	8.8 1988	8.3 1860	7.8 1761	7.5 1681	7.2 1615	6.9 1559	6.7 1511	6.6 1482	6.4 1442
			100000	19.7 4426	16.0 3595	13.0 2920	9.9 2218	8.0 1802	7.6 1706	7.1 1595	6.7 1511	6.4 1442	6.2 1386	6.0 1338	5.8 1296	5.7 1271	5.5 1237
						50	100	200	500	1000	1200	1500	1800	2100	2400	2700	3000
45 1 11/16, 1 3/4	22210	117 26300	10000	42.2 9480	34.3 7700	27.8 6255	21.1 4751	17.2 3859	16.3 3654	15.2 3417	14.4 3235	13.7 3089	13.2 2968	12.7 2865	12.3 2776	12.1 2723	11.8 2650
			30000	30.3 6818	24.6 5538	20.0 4498	15.2 3417	12.3 2776	11.7 2628	10.9 2458	10.4 2327	9.9 2222	9.5 2135	9.2 2060	8.9 1996	8.7 1958	8.5 1906
			40000	27.8 6255	22.6 5080	18.4 4127	13.9 3135	11.3 2546	10.7 2411	10.0 2255	9.5 2135	9.1 2038	8.7 1958	8.4 1890	8.1 1831	8.0 1796	7.8 1749
			60000	24.6 5538	20.0 4498	16.3 3654	12.3 2776	10.0 2255	9.5 2135	8.9 1996	8.4 1890	8.0 1805	7.7 1734	7.4 1674	7.2 1622	7.1 1590	6.9 1548
			100000	21.1 4751	17.2 3859	13.9 3135	10.6 2381	8.6 1934	8.1 1831	7.6 1713	7.2 1622	6.9 1548	6.6 1487	6.4 1436	6.2 1391	6.1 1364	5.9 1328
						50	100	200	500	1000	1200	1500	1800	2100	2400	2700	3000
50 1 15/16, 2	22211	140 31400	10000	50.3 11319	40.9 9194	33.2 7468	25.2 5673	20.5 4608	19.4 4362	18.1 4080	17.2 3863	16.4 3688	15.8 3543	15.2 3420	14.7 3314	14.5 3250	14.1 3164
			30000	36.2 8141	29.4 6612	23.9 5371	18.1 4080	14.7 3314	14.0 3138	13.1 2934	12.4 2778	11.8 2653	11.3 2549	10.9 2460	10.6 2383	10.4 2338	10.1 2276
			40000	33.2 7468	27.0 6066	21.9 4927	16.6 3743	13.5 3040	12.8 2878	12.0 2692	11.3 2549	10.8 2433	10.4 2338	10.0 2257	9.7 2186	9.5 2144	9.3 2088
			60000	29.4 6612	23.9 5371	19.4 4362	14.7 3314	12.0 2692	11.3 2549	10.6 2383	10.0 2257	9.6 2155	9.2 2070	8.9 1998	8.6 1936	8.4 1899	8.2 1849
			100000	25.2 5673	20.5 4608	16.6 3743	12.6 2843	10.3 2309	9.7 2186	9.1 2045	8.6 1936	8.2 1849	7.9 1776	7.6 1714	7.4 1661	7.2 1629	7.1 1586
						50	100	200	500	1000	1200	1500	1800	2100	2400	2700	3000
55 –	22212	169 38100	10000	61.1 13734	49.6 11155	40.3 9061	30.6 6883	24.9 5591	23.5 5293	22.0 4951	20.8 4687	19.9 4475	19.1 4300	18.5 4150	17.9 4021	17.5 3944	17.1 3839
			30000	43.9 9878	35.7 8023	29.0 6517	22.0 4951	17.9 4021	16.9 3807	15.8 3561	15.0 3371	14.3 3219	13.8 3092	13.3 2985	12.9 2892	12.6 2837	12.3 2761
			40000	40.3 9061	32.7 7360	26.6 5978	20.2 4541	16.4 3689	15.5 3492	14.5 3266	13.8 3092	13.1 2953	12.6 2837	12.2 2738	11.8 2653	11.6 2602	11.3 2533
			60000	35.7 8023	29.0 6517	23.5 5293	17.9 4021	14.5 3266	13.8 3092	12.9 2892	12.2 2738	11.6 2614	11.2 2512	10.8 2425	10.4 2349	10.2 2304	10.0 2243
			100000	30.6 6883	24.9 5591	20.2 4541	15.3 3450	12.5 2802	11.8 2653	11.0 2481	10.4 2349	10.0 2243	9.6 2155	9.3 2080	9.0 2015	8.8 1977	8.6 1924
						50	100	200	500	1000	1200	1500	1800	2100	2400	2700	3000 ⁽¹⁾
60 2 3/16, 2 1/4	22213	206 46400	10000	74.4 16726	60.4 13585	49.1 11035	37.3 8383	30.3 6809	28.7 6446	26.8 6029	25.4 5708	24.2 5450	23.3 5236	22.5 5054	21.8 4897	21.4 4803	20.8 4676
			30000	53.5 12030	43.5 9771	35.3 7937	26.8 6029	21.8 4897	20.6 4636	19.3 4336	18.3 4105	17.4 3920	16.8 3766	16.2 3635	15.7 3522	15.4 3455	15.0 3363
			40000	49.1 11035	39.9 8963	32.4 7280	24.6 5531	20.0 4492	18.9 4253	17.7 3978	16.8 3766	16.0 3596	15.4 3455	14.8 3335	14.4 3231	14.1 3169	13.7 3085
			60000	43.5 9771	35.3 7937	28.7 6446	21.8 4897	17.7 3978	16.8 3766	15.7 3522	14.8 3335	14.2 3184	13.6 3059	13.1 2953	12.7 2861	12.5 2806	12.2 2732
			100000	37.3 8383	30.3 6809	24.6 5531	18.7 4201	15.2 3413	14.4 3231	13.4 3022	12.7 2861	12.2 2732	11.7 2624	11.3 2533	10.9 2454	10.7 2407	10.4 2343
						50	100	200	500	1000	1200	1500	1800	2100	2400	2700	3000 ⁽¹⁾

⁽¹⁾Speeds referenced here may be higher than speed rating for seals. Please refer to the charts on pages 56 – 58.

⁽²⁾For speeds greater than thermal reference speed, contact your Timken engineer.

Continued on next page.

Continued from previous page.

Shaft Diameter	Bearing No.	C	L ₁₀ Life	Speed ⁽²⁾												
				RPM												
mm in.		kN lbs.		50	100	200	500	1000	1200	1500	1800	2100	2400	2700 ⁽¹⁾	3000 ⁽¹⁾	3200 ⁽¹⁾
65 2 7/16, 2 1/2	22215	222 49900	10000	80.0 17987	65.0 14610	52.8 11867	40.1 9015	32.6 7322	30.8 6933	28.8 6484	27.3 6139	26.1 5861	25.0 5631	24.2 5436	23.4 5266	23.0 5166
			30000	57.5 12937	46.7 10508	38.0 8535	28.8 6484	23.4 5266	22.2 4986	20.7 4663	19.6 4415	18.8 4216	18.0 4050	17.4 3909	16.8 3788	16.5 3715
			40000	52.8 11867	42.9 9639	34.8 7829	26.5 5948	21.5 4831	20.3 4574	19.0 4278	18.0 4050	17.2 3867	16.5 3715	16.0 3586	15.5 3475	15.2 3408
			60000	46.7 10508	38.0 8535	30.8 6933	23.4 5266	19.0 4278	18.0 4050	16.8 3788	16.0 3586	15.2 3424	14.6 3290	14.1 3175	13.7 3077	13.4 3018
			100000	40.1 9015	32.6 7322	26.5 5948	20.1 4518	16.3 3670	15.5 3475	14.5 3250	13.7 3077	13.1 2938	12.6 2822	12.1 2724	11.7 2639	11.5 2589
						50	100	200	500	1000	1200	1500	1800	2100	2400 ⁽¹⁾	2700 ⁽¹⁾
70 2 11/16, 2 3/4	22216	254 57200	10000	91.7 20619	74.5 16748	60.5 13603	46.0 10334	37.3 8394	35.4 7947	33.1 7432	31.3 7037	29.9 6719	28.7 6455	27.7 6231	26.9 6037	
			30000	66.0 14829	53.6 12045	43.5 9784	33.1 7432	26.9 6037	25.4 5716	23.8 5346	22.5 5061	21.5 4832	20.7 4643	19.9 4481	19.3 4342	
			40000	60.5 13603	49.1 11049	39.9 8975	30.3 6818	24.6 5538	23.3 5243	21.8 4904	20.7 4643	19.7 4433	18.9 4259	18.3 4111	17.7 3983	
			60000	53.6 12045	43.5 9784	35.4 7947	26.9 6037	21.8 4904	20.7 4643	19.3 4342	18.3 4111	17.5 3925	16.8 3771	16.2 3640	15.7 3527	
			100000	46.0 10334	37.3 8394	30.3 6818	23.0 5179	18.7 4207	17.7 3983	16.6 3725	15.7 3527	15.0 3367	14.4 3235	13.9 3123	13.5 3026	
						50	100	200	500	1000	1200	1500	1800	2100 ⁽¹⁾	2400 ⁽¹⁾	2700 ⁽¹⁾
75 2 15/16, 3	22217	297 66900	10000	107.3 24115	87.1 19588	70.8 15910	53.8 12086	43.7 9817	41.3 9295	38.7 8693	36.6 8230	35.0 7858	33.6 7550	32.4 7287		
			30000	77.1 17344	62.7 14088	50.9 11443	38.7 8693	31.4 7061	29.7 6685	27.8 6252	26.3 5919	25.1 5652	24.2 5430	23.3 5241		
			40000	70.8 15910	57.5 12923	46.7 10497	35.5 7974	28.8 6477	27.3 6132	25.5 5735	24.2 5430	23.1 5184	22.2 4981	21.4 4808		
			60000	62.7 14088	50.9 11443	41.3 9295	31.4 7061	25.5 5735	24.2 5430	22.6 5078	21.4 4808	20.4 4591	19.6 4410	18.9 4257		
			100000	53.8 12086	43.7 9817	35.5 7974	26.9 6057	21.9 4920	20.7 4658	19.4 4357	18.3 4125	17.5 3938	16.8 3784	16.2 3652		
						50	100	200	500	1000	1200	1500	1800	2100 ⁽¹⁾	2400 ⁽¹⁾	2700 ⁽¹⁾
80 3 3/16, 3 1/4	22218	355 79700	10000	127.8 28729	103.8 23335	84.3 18954	64.0 14399	52.0 11695	49.3 11073	46.1 10356	43.6 9805	41.6 9362	40.0 8994	38.6 8682		
			30000	91.9 20663	74.7 16783	60.6 13632	46.1 10356	37.4 8412	35.4 7964	33.1 7448	31.4 7052	29.9 6733	28.8 6469	27.8 6244		
			40000	84.3 18954	68.5 15396	55.6 12505	42.3 9500	34.3 7716	32.5 7305	30.4 6832	28.8 6469	27.5 6176	26.4 5934	25.5 5728		
			60000	74.7 16783	60.6 13632	49.3 11073	37.4 8412	30.4 6832	28.8 6469	26.9 6050	25.5 5728	24.3 5469	23.4 5254	22.6 5072		
			100000	64.0 14399	52.0 11695	42.3 9500	32.1 7216	26.1 5862	24.7 5550	23.1 5190	21.9 4914	20.9 4692	20.1 4508	19.4 4351		
						50	100	200	500	1000	1200	1500	1800	2100 ⁽¹⁾	2400 ⁽¹⁾	2700 ⁽¹⁾
85 —	22219	385 86600	10000	138.9 31216	112.8 25356	91.6 20595	69.6 15645	56.5 12708	53.5 12032	50.1 11252	47.4 10654	45.2 10172	43.5 9773	42.0 9433		
			30000	99.9 22452	81.1 18236	65.9 14813	50.1 11252	40.7 9140	38.5 8653	36.0 8093	34.1 7662	32.5 7316	31.3 7029	30.2 6785		
			40000	91.6 20595	74.4 16729	60.4 13588	45.9 10322	37.3 8384	35.3 7938	33.0 7424	31.3 7029	29.9 6711	28.7 6448	27.7 6224		
			60000	81.1 18236	65.9 14813	53.5 12032	40.7 9140	33.0 7424	31.3 7029	29.2 6574	27.7 6224	26.4 5942	25.4 5709	24.5 5511		
			100000	69.6 15645	56.5 12708	45.9 10322	34.9 7841	28.3 6369	26.8 6030	25.1 5640	23.7 5339	22.7 5098	21.8 4898	21.0 4728		
						50	100	200	500	1000	1200	1500	1800	2100 ⁽¹⁾	2400 ⁽¹⁾	2700 ⁽¹⁾

⁽¹⁾Speeds referenced here may be higher than speed rating for seals. Please refer to the charts on pages 56 – 58.

⁽²⁾For speeds greater than thermal reference speed, contact your Timken engineer.

Continued on next page.

LOAD RATINGS – continued

TABLE 28. TA - ALLOWABLE RADIAL LOAD (kN/LBS.) AT VARIOUS RPM⁽¹⁾

Shaft Diameter	Bearing No.	C	L ₁₀ Life	Speed ⁽²⁾																
				RPM																
mm in.		kN lbs.		50	100	200	500	1000	1200	1500	1800 ⁽¹⁾	2100 ⁽¹⁾	2400 ⁽¹⁾	2700 ⁽¹⁾						
90 3 7/16, 3 1/2	22220	435 97700	10000	156.7 35218	127.2 28606	103.4 23235	78.5 17651	63.8 14337	60.4 13574	56.5 12695	53.5 12019	51.0 11476	49.0 11025	47.3 10642						
			30000	112.7 25329	91.5 20574	74.3 16711	56.5 12695	45.9 10311	43.4 9762	40.6 9130	38.5 8644	36.7 8254	35.3 7930	34.0 7654						
			40000	103.4 23235	84.0 18873	68.2 15329	51.8 11645	42.1 9459	39.8 8955	37.3 8375	35.3 7930	33.7 7571	32.4 7274	31.2 7021	30.3 6803	28.3 6362	26.8 6024	25.6 5752	24.6 5526	23.7 5334
			60000	91.5 20574	74.3 16711	60.4 13574	45.9 10311	37.3 8375	35.3 7930	33.0 7416	31.2 7021	29.8 6704	28.7 6441	27.7 6217						
			100000	78.5 17651	63.8 14337	51.8 11645	39.3 8846	32.0 7185	30.3 6803	28.3 6362	26.8 6024	25.6 5752	24.6 5526	23.7 5334						
							50	100	200	500	1000	1200	1500 ⁽¹⁾	1800 ⁽¹⁾	2100 ⁽¹⁾	2400 ⁽¹⁾				
100 3 1/16, 4	22222	555 125000	10000	200.4 45058	162.8 36599	132.2 29727	100.5 22583	81.6 18343	77.3 17367	72.2 16242	68.4 15377	65.3 14683	62.7 14106							
			30000	144.2 32407	117.1 26323	95.1 21381	72.2 16242	58.7 13193	55.6 12490	52.0 11682	49.2 11060	47.0 10560	45.1 10145	44.1 9906						
			40000	132.2 29727	107.4 24146	87.2 19613	66.3 14899	53.8 12102	51.0 11458	47.7 10716	45.1 10145	43.1 9687	41.4 9306							
			60000	117.1 26323	95.1 21381	77.3 17367	58.7 13193	47.7 10716	45.1 10145	42.2 9488	40.0 8983	38.2 8577	36.7 8241							
			100000	100.5 22583	81.6 18343	66.3 14899	50.3 11318	40.9 9193	38.7 8704	36.2 8140	34.3 7707	32.7 7359	31.4 7070							
							50	100	200	500	1000	1200	1500 ⁽¹⁾	1800 ⁽¹⁾	2100 ⁽¹⁾	2400 ⁽¹⁾				
110 4 3/16, 4 1/4	22224	647 145000	10000	232.5 52268	188.8 42455	153.4 34484	116.5 26196	94.6 21278	89.6 20145	83.8 18841	79.3 17838	75.8 17032	72.8 16363							
			30000	167.2 37592	135.8 30534	110.3 24802	83.8 18841	68.1 15303	64.5 14489	60.3 13551	57.1 12829	54.5 12250	52.4 11769							
			40000	153.4 34484	124.6 28010	101.2 22751	76.9 17283	62.4 14038	59.1 13291	55.3 12430	52.4 11769	50.0 11237	48.0 10796							
			60000	135.8 30534	110.3 24802	89.6 20145	68.1 15303	55.3 12430	52.4 11769	49.0 11007	46.4 10421	44.3 9950	42.5 9559							
			100000	116.5 26196	94.6 21278	76.9 17283	58.4 13129	47.4 10664	44.9 10097	42.0 9443	39.8 8940	38.0 8536	36.5 8201							
							50	100	200	500	1000	1200 ⁽¹⁾	1500 ⁽¹⁾	1800 ⁽¹⁾	2100 ⁽¹⁾					
115 4 7/16, 4 1/2	22226	757 170000	10000	272.6 61279	221.4 49774	179.8 40429	136.6 30712	111.0 24946	105.1 23618	98.3 22089	93.0 20913	88.8 19968								
			30000	196.1 44074	159.2 35799	129.3 29078	98.3 22089	79.8 17942	75.6 16987	70.7 15887	66.9 15041	63.9 14362								
			40000	179.8 40429	146.1 32839	118.6 26673	90.1 20263	73.2 16458	69.3 15582	64.8 14573	61.4 13798	58.6 13174								
			60000	159.2 35799	129.3 29078	105.1 23618	79.8 17942	64.8 14573	61.4 13798	57.4 12904	54.3 12217	51.9 11665								
			100000	136.6 30712	111.0 24946	90.1 20263	68.5 15393	55.6 12503	52.7 11837	49.2 11071	46.6 10482	44.5 10008								
							50	100	200	500	1000 ⁽¹⁾	1200 ⁽¹⁾	1500 ⁽¹⁾	1800 ⁽¹⁾						
125 4 1/16, 5	22228	863 194000	10000	311.1 69931	252.7 56801	205.2 46137	155.9 35048	126.6 28468	119.9 26953	112.1 25208	106.2 23866									
			30000	223.7 50296	181.7 40853	147.6 33183	112.1 25208	91.1 20475	86.2 19385	80.6 18130	76.4 17165									
			40000	205.2 46137	166.7 37475	135.4 30439	102.9 23123	83.5 18782	79.1 17782	74.0 16631	70.0 15746									
			60000	181.7 40853	147.6 33183	119.9 26953	91.1 20475	74.0 16631	70.0 15746	65.5 14726	62.0 13942									
			100000	155.9 35048	126.6 28468	102.9 23123	78.1 17566	63.5 14268	60.1 13508	56.2 12634	53.2 11961									
							50	100	200	500	1000 ⁽¹⁾	1200 ⁽¹⁾	1500 ⁽¹⁾	1800 ⁽¹⁾						

⁽¹⁾Speeds referenced here may be higher than speed rating for seals. Please refer to the charts on pages 56 – 58.

⁽²⁾For speeds greater than thermal reference speed, contact your Timken engineer.

Continued on next page.

Continued from previous page.

Shaft Diameter	Bearing No.	C	L ₁₀ Life	Speed ⁽²⁾						
				RPM						
mm in.		kN lbs.		50.0	100.0	200.0	500.0	1000.0	1200.0	1500.0
135, 140 5 3/8, 5 7/16, 5 1/2	23132	1160 261000	10000	418.1 94072.4	339.6 76409.0	275.8 62062.1	209.5 47144.6	170.2 38292.6	161.1 36254.1	150.7 33906.4
			30000	300.7 67656.8	244.2 54953.3	198.4 44635.0	150.7 33906.4	122.4 27540.0	115.9 26074.0	108.4 24385.5
			40000	275.8 62062.1	224.0 50409.0	182.0 40944.0	138.2 31102.6	112.3 25262.6	106.3 23917.8	99.4 22369.0
			60000	244.2 54953.3	198.4 44635.0	161.1 36254.1	122.4 27540.0	99.4 22369.0	94.1 21178.2	88.0 19806.7
			100000	209.5 47144.6	170.2 38292.6	138.2 31102.6	105.0 23626.7	85.3 19190.4	80.8 18168.9	75.5 16992.3
							50.0	100.0	200.0	500.0
150 5 13/16, 5 7/8, 5 15/16, 6	23134	1220 274000	10000	439.7 98758.0	357.2 80214.8	290.1 65153.3	220.4 49492.9	179.0 40199.9	169.5 38059.9	
			30000	316.3 71026.7	256.9 57690.4	208.6 46858.2	158.5 35595.2	128.7 28911.7	121.9 27372.7	
			40000	290.1 65153.3	235.6 52919.8	191.4 42983.4	145.4 32651.7	118.1 26520.9	111.8 25109.1	
			60000	256.9 57690.4	208.6 46858.2	169.5 38059.9	128.7 28911.7	104.6 23483.1	99.0 22233.0	
			100000	220.4 49492.9	179.0 40199.9	145.4 32651.7	110.4 24803.5	89.7 20146.3	84.9 19073.8	
							50.0	100.0	200.0	500.0
160 6 3/16, 6 3/8, 6 7/16, 6 1/2	23136	1410 317000	10000	508.2 114256.6	412.8 92803.2	335.3 75378.1	254.7 57260.0	206.9 46508.6	195.9 44032.8	
			30000	365.5 82173.3	296.9 66744.0	241.1 54211.9	183.2 41181.3	148.8 33448.9	140.9 31668.4	
			40000	335.3 75378.1	272.3 61224.0	221.2 49728.9	168.0 37775.9	136.5 30682.9	129.2 29049.6	
			60000	296.9 66744.0	241.1 54211.9	195.9 44032.8	148.8 33448.9	120.8 27168.4	114.4 25722.2	
			100000	254.7 57260.0	206.9 46508.6	168.0 37775.9	127.6 28696.0	103.7 23307.9	98.2 22067.2	
							50.0	100.0	200.0	500.0
170 6 13/16, 6 7/8, 6 15/16, 7	23138	1630 366000	10000	587.5 131917.7	477.2 107148.2	387.6 87029.6	294.4 66110.9	239.1 53697.6	226.4 50839.1	
			30000	422.5 94875.1	343.2 77060.9	278.8 62591.6	211.8 47546.9	172.0 38619.3	162.8 36563.5	
			40000	387.6 87029.6	314.8 70688.5	255.7 57415.7	194.2 43615.1	157.8 35425.7	149.4 33539.9	
			60000	343.2 77060.9	278.8 62591.6	226.4 50839.1	172.0 38619.3	139.7 31368.0	132.3 29698.2	
			100000	294.4 66110.9	239.1 53697.6	194.2 43615.1	147.6 33131.6	119.8 26910.7	113.5 25478.2	
							50.0	100.0	200.0	500.0
180 7 1/8, 7 3/16, 7 1/4	23140	1660 373000	10000	598.3 134440.7	486.0 109197.5	394.7 88694.1	299.8 67375.3	243.5 54724.6	230.6 51811.5	
			30000	430.3 96689.7	349.5 78534.8	283.9 63788.7	215.6 48456.3	175.2 39357.9	165.8 37262.8	
			40000	394.7 88694.1	320.6 72040.5	260.4 58513.8	197.8 44449.3	160.7 36103.3	152.1 34181.4	
			60000	349.5 78534.8	283.9 63788.7	230.6 51811.5	175.2 39357.9	142.3 31967.9	134.7 30266.2	
			100000	299.8 67375.3	243.5 54724.6	197.8 44449.3	150.3 33765.3	122.1 27425.4	115.6 25965.5	
							50.0	100.0	200.0	500.0

⁽¹⁾Speeds referenced here may be higher than speed rating for seals. Please refer to the charts on pages 56 – 58.

⁽²⁾For speeds greater than thermal reference speed, contact your Timken engineer.

Continued on next page.

LOAD RATINGS – continued

TABLE 28. TA - ALLOWABLE RADIAL LOAD (kN/LBS.) AT VARIOUS RPM⁽¹⁾

Shaft Diameter	Bearing No.	C	L ₁₀ Life	Speed ⁽²⁾				
				RPM				
mm in.		kN lbs.		50.0	100.0	200.0	500.0	1000.0
200 7 13/16, 7 7/8, 7 15/16, 8	23144	1940 436000	10000	699.2 157147.8	567.9 127641.1	461.3 103674.6	350.4 78755.0	284.6 63967.6
			30000	502.9 113020.6	408.5 91799.4	331.8 74562.7	252.0 56640.6	204.7 46005.5
			40000	461.3 103674.6	374.7 84208.2	304.3 68396.9	231.2 51956.8	187.8 42201.2
			60000	408.5 91799.4	331.8 74562.7	269.5 60562.5	204.7 46005.5	166.3 37367.3
			100000	350.4 78755.0	284.6 63967.6	231.2 51956.8	175.6 39468.3	142.6 32057.6
				50.0	100.0	200.0	500.0	
220 8 7/16, 8 1/2, 8 15/16, 9	23148	2200 495000	10000	792.9 178413.3	644.1 144913.6	523.1 117703.0	397.4 89412.3	
			30000	570.3 128314.7	463.2 104221.8	376.2 84652.6	285.8 64305.2	
			40000	523.1 117703.0	424.9 95603.3	345.1 77652.4	262.2 58987.6	
			60000	463.2 104221.8	376.2 84652.6	305.6 68757.9	232.1 52231.0	
			100000	397.4 89412.3	322.8 72623.8	262.2 58987.6	199.2 44809.2	
				50.0	100.0	200.0	500.0	
240 9 7/16, 9 1/2	23152	2440 549000	10000	879.5 197876.5	714.3 160722.3	580.2 130544.4	440.7 99166.3	
			30000	632.5 142312.7	513.7 115591.4	417.3 93887.4	317.0 71320.4	
			40000	580.2 130544.4	471.3 106032.8	382.8 86123.6	290.8 65422.7	
			60000	513.7 115591.4	417.3 93887.4	338.9 76258.7	257.5 57928.9	
			100000	440.7 99166.3	358.0 80546.4	290.8 65422.7	220.9 49697.5	
				50.0	100.0	200.0	500.0	
260 9 15/16, 10, 10 7/16, 10 1/2	23156	2530 569000	10000	911.9 205085.1	740.7 166577.4	601.6 135300.1	457.0 102778.9	
			30000	655.8 147497.1	532.7 119802.4	432.7 97307.7	328.7 73918.6	
			40000	601.6 135300.1	488.6 109895.5	396.9 89261.1	301.5 67806.0	
			60000	532.7 119802.4	432.7 97307.7	351.4 79036.8	267.0 60039.3	
			100000	457.0 102778.9	371.2 83480.7	301.5 67806.0	229.0 51507.9	
				50.0	100.0	200.0	500.0	
280 10 15/16, 11	23160	3070 690000	10000	1106.5 248697.3	898.8 202000.7	730.0 164072.2	554.5 1246353	
			30000	795.8 178862.9	646.4 145278.8	525.0 118000.6	398.8 89637.6	
			40000	730.0 164072.2	592.9 133265.2	481.6 108242.8	365.8 82225.2	
			60000	646.4 145278.8	525.0 118000.6	426.4 95844.3	323.9 72806.9	
			100000	554.5 124635.3	450.4 101233.2	365.8 82225.2	277.9 62461.3	
				50.0	100.0	200.0	500.0	

⁽¹⁾ Speeds referenced here may be higher than speed ratings for seals. Please refer to the charts on page 56 – 58.

⁽²⁾ For speeds greater than thermal reference speed, contact your Timken engineer.

Continued on next page.

Continued from previous page.

Shaft Diameter	Bearing No.	C	L ₁₀ Life	Speed ⁽²⁾			
				RPM			
mm in.		kN lbs.		50.0	100.0	200.0	500.0
300 11 7/16, 11 1/2, 11 15/16, 12	23164	3650 821000		50.0	100.0	200.0	500.0
			10000	1315.6 295913.7	1068.6 240351.6	867.9 195222.1	659.3 148297.9
			30000	946.2 212820.9	768.5 172860.7	624.2 140403.6	474.2 106655.8
			40000	867.9 195222.1	705.0 158566.3	572.6 128793.2	435.0 97836.1
			60000	768.5 172860.7	624.2 140403.6	507.0 114040.8	385.1 86629.6
			100000	659.3 148297.9	535.5 120452.8	435.0 97836.1	330.4 74319.9
320 12 7/16, 12 1/2	23168	4110 924000		50.0	100.0	200.0	500.0
			10000	1481.4 333038.1	1203.2 270505.3	977.3 219714.0	742.4 166902.9
			30000	1065.4 239520.8	865.4 194547.3	702.9 158018.2	533.9 120036.5
			40000	977.3 219714.0	793.8 178459.5	644.8 144951.2	489.8 110110.3
			60000	865.4 194547.3	702.9 158018.2	570.9 128348.0	433.7 97497.9
			100000	742.4 166902.9	603.0 135564.5	489.8 110110.3	372.1 83643.8
340 12 15/16, 13, 13 7/16, 13 1/2	23172	4250 955000		50.0	100.0	200.0	500.0
			10000	1531.8 344211.4	1244.2 279580.7	1010.6 227085.4	767.7 172502.5
			30000	1101.7 247556.6	894.8 201074.3	726.8 163319.7	552.1 124063.7
			40000	1010.6 227085.4	820.8 184446.8	666.7 149814.3	506.5 113804.4
			60000	894.8 201074.3	726.8 163319.7	590.3 132654.0	448.4 100768.9
			100000	767.7 172502.5	623.5 140112.6	506.5 113804.4	384.7 86450.1
360 13 15/16, 14	23176	4490 1009000		50.0	100.0	200.0	500.0
			10000	1618.3 363674.7	1314.5 295389.5	1067.7 239925.8	
			30000	1163.9 261554.6	945.4 212443.9	767.9 172554.5	
			40000	1067.7 239925.8	867.2 194876.3	704.4 158285.4	
			60000	945.4 212443.9	767.9 172554.5	623.7 140154.9	
			100000	811.0 182256.5	658.7 148035.2	535.1 120239.5	
380 14 15/16, 15	23180	4770 1072000		50.0	100.0	200.0	500.0
			10000	1719.3 386381.8	1396.4 313833.0	1134.2 254906.3	
			30000	1236.5 277885.6	1004.3 225708.5	815.7 183328.5	
			40000	1134.2 254906.3	921.3 207044.0	748.3 168168.5	
			60000	1004.3 225708.5	815.7 183328.5	662.6 148905.9	
			100000	861.6 193636.3	699.8 157278.2	568.4 127746.0	

(1) Speeds referenced here may be higher than speed ratings for seals. Please refer to the charts on page 56 – 58.

(2) For speeds greater than thermal reference speed, contact your Timken engineer.

HOUSING LOADS

Because solid-block housed units are made of cast steel, they are built to last with high allowable load limits in multiple orientations.

Refer to the table below for the maximum recommended housing load limit.

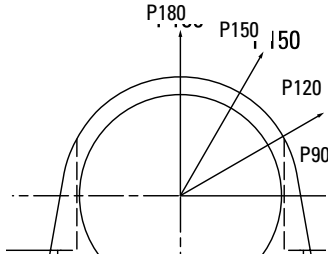

Fig. 32. Allowable housing loads.

CAUTION
*Failure to follow these cautions
 could create a risk of injury.*

Do not use damaged housed units. The use of a damaged housed unit can result in equipment damage and/or injury.

TABLE 29. HOUSING CAPACITY CHART – QA/QM/TA/TAA SERIES

Bearing No.	Maximum Recommended Housing Loads	
	Two-Bolt	Four-Bolt
	kN lbs.	kN lbs.
22208	109 24400	N/A
22209	117 26400	N/A
22210	134 30200	N/A
22211	158 35400	158 35400
22212	174 39000	174 39000
22213	228 51300	235 52800
22214	N/A	N/A
22215	266 59700	267 60000
22216	278 62500	278 62500
22217	320 71900	320 71900
22218	404 90700	425 95500
22219	386 86800	433 97400
22220	512 115000	512 115000
22222	478 107400	677 152100
22224	494 110900	547 123000
22226	687 154300	837 188200
22228	745 167500	N/A
23230	1655 372000	1512 339700
23234	N/A	2198 494000

The values listed above are the maximum recommended housing load ratings; these loads may exceed bearing, mounting bolt and/or shaft capacities. When side load is present, stop bars or shear strips should be used against the machined housing foot ends.

TABLE 30. HOUSING CAPACITY CHART – QV/DV/DAA SERIES

Bearing No.	Maximum Recommended Housing Loads	
	Two-Bolt	Four-Bolt
	kN lbs.	kN lbs.
22208	N/A	N/A
22209	117 26400	N/A
22210	134 30200	N/A
22211	158 35400	N/A
22212	174 39000	N/A
22213	228 51300	N/A
22214	231 52000	231 52000
22215	266 59700	N/A
22216	278 62500	278 62500
22217	320 71900	238 53500
22218	N/A	N/A
22219	394 88600	399 89700
22220	512 115000	423 95000
22222	677 152100	677 152100
22224	N/A	N/A
22226	837 188200	837 188200
22228	828 186000	576 129400
23230	N/A	N/A
23234	N/A	N/A

The values listed above are the maximum recommend housing load ratings; these loads may exceed bearing, mounting bolt and/or shaft capacities. When side load is present, stop bars or shear strips should be used against the machined housing foot ends.

TABLE 31. HOUSING CAPACITY CHART – TAA SERIES (ONLY)

Bearing No.	Maximum Recommended Housing Loads	
	Two-Bolt	Four-Bolt
	kN lbs.	kN lbs.
23132	N/A	520 116901
23134	N/A	610 137134
23136	N/A	705 158491
23138	N/A	815 183220
23140	N/A	830 186592
23144	N/A	970 218066
23148	N/A	1100 247291
23152	N/A	1220 274268
23156	N/A	1265 284385
23160	N/A	1535 345083
23164	N/A	1825 410278
23168	N/A	2055 461985
23172	N/A	2125 477721
23176	N/A	2245 504698
23180	N/A	2385 536172

The values listed above are the maximum recommend housing load ratings; these loads may exceed bearing, mounting bolt and/or shaft capacities. When side load is present, stop bars or shear strips should be used against the machined housing foot ends.

NORMAL SPEED RATINGS FOR SEALS**TABLE 32. V-LOCK SERIES NORMAL SEAL SPEED RATINGS**

Shaft Dia.	Bearing No.	Oil Lubrication			Grease Lubrication		
		M/N Seal ⁽¹⁾	T Seal	B/C/O Seal ⁽¹⁾	M/N Seal ⁽¹⁾	T Seal	B/C/O Seal ⁽¹⁾
mm in.		RPM	RPM	RPM	RPM	RPM	RPM
50 1 15/16, 2	22211	2200	3800	1800	2200	3200	1600
55 2 3/16, 2 1/4	22212 22213	2000 1800	3500 3200	1650 1500	2000 1800	3000 2800	1550 1500
60, 65 2 7/16, 2 1/2	22214 22215	1700 1600	3050 2900	1400 1300	1700 1600	2600 2400	1400 1300
70, 75 2 11/16, 2 3/4, 2 15/16, 3	22216 22217	1500 1400	2650 2400	1200 1100	1500 1400	2200 2000	1150 1100
80, 85, 90 3 3/16, 3 1/4, 3 7/16, 3 1/2	22219 22220	1300 1200	2200 2000	1000 900	1300 1200	1800 1600	950 900
100 3 11/16, 3 3/4, 3 15/16, 4	22222	900	1700	600	900	1200	600
110, 115 4 7/16, 4 1/2	22224 22226	700	1500	400	700	1000	400
125, 130 4 15/16, 5	22228	650	1200	350	650	900	350

⁽¹⁾Bearings with contact seals will have higher operating temperatures than bearings with labyrinth seals.

TABLE 33. CL SERIES NORMAL SEAL SPEED RATINGS

Shaft Dia.	Bearing No.	Oil Lubrication			Grease Lubrication		
		M/N Seal ⁽¹⁾	T Seal	B/C/O Seal ⁽¹⁾	M/N Seal ⁽¹⁾	T Seal	B/C/O Seal ⁽¹⁾
mm in.		RPM	RPM	RPM	RPM	RPM	RPM
35 1 7/16, 1 1/2	22208	2700	4500	1950	2700	4000	1950
40, 45 1 11/16, 1 3/4	22209	2700	4500	1950	2700	4000	1950
50 1 15/16, 2	22210	2400	4200	1800	2400	3550	1800
55 2 3/16, 2 1/4	22211	2200	3800	1600	2200	3200	1600
60, 65 2 7/16, 2 1/2	22213	1800	3200	1500	1800	2800	1500
70, 75 2 11/16, 2 3/4, 2 15/16, 3	22215	1600	2900	1300	1600	2400	1300
80, 85, 90 3 3/16, 3 1/4, 3 7/16, 3 1/2	22218	1400	2400	1000	1400	2000	1000
100 3 15/16, 4	22220	1200	2000	900	1200	1600	900
110, 115 4 7/16, 4 1/2	22222	900	1700	600	900	1200	600
125, 130 4 15/16, 5	22226	700	1500	400	700	1000	400

⁽¹⁾Bearings with contact seals will have higher operating temperatures than bearings with labyrinth seals.

TABLE 34. EC SERIES NORMAL SEAL SPEED RATINGS

Shaft Dia.	Bearing No.	Oil Lubrication			Grease Lubrication		
		M/N Seal ⁽¹⁾	T Seal	B/C/O Seal ⁽¹⁾	M/N Seal ⁽¹⁾	T Seal	B/C/O Seal ⁽¹⁾
mm in.		RPM	RPM	RPM	RPM	RPM	RPM
35 1 7/16, 1 1/2	22208	2700	4500	1950	2700	4000	1950
40, 45 1 11/16, 1 3/4	22209	2700	4500	1950	2700	4000	1950
50 1 15/16, 2	22210	2400	4200	1800	2400	3550	1800
55 2 3/16, 2 1/4	22211	2200	3800	1600	2200	3200	1600
60, 65 2 7/16, 2 1/2	22213	1800	3200	1500	1800	2800	1500
70, 75 2 11/16, 2 3/4, 2 15/16, 3	22215	1600	2900	1300	1600	2400	1300
80, 85, 90 3 3/16, 3 1/4, 3 7/16, 3 1/2	22218	1400	2400	1000	1400	2000	1000
100 3 11/16, 3 3/4, 3 15/16, 4	22220	1200	2000	900	1200	1600	900
110, 115 4 7/16, 4 1/2	22222	900	1700	600	900	1200	600
125, 130 4 15/16, 5	22226	700	1500	400	700	1000	400
140, 150 5 7/16, 5 1/2, 5 15/16, 6	23230	650	950	350	600	800	350
170, 180 6 7/16, 6 1/2, 6 15/16, 7	23234	600	900	350	600	800	350

⁽¹⁾Bearings with contact seals will have higher operating temperatures than bearings with labyrinth seals.

NORMAL SPEED RATINGS FOR SEALS – continued

TABLE 35. TA/DV TAA/DVV SERIES NORMAL SEAL SPEED RATINGS

Shaft Dia.	Bearing No.	Oil Lubrication			Grease Lubrication		
		M/N Seal ⁽¹⁾	T Seal	B/C/O Seal ⁽¹⁾	M/N Seal ⁽¹⁾	T Seal	B/C/O Seal ⁽¹⁾
mm in.		RPM	RPM	RPM	RPM	RPM	RPM
40 1 7/16, 1 1/2	22209	2700	4500	1950	2700	4000	1950
45 1 11/16, 1 3/4	22210	2400	4200	1800	2400	3550	1800
50 1 15/16, 2	22211	2200	3800	1800	2200	3200	1600
55 –	22212	2000	3500	1650	2000	3000	1550
60 2 3/16, 2 1/4	22213	1800	3200	1500	1800	2800	1500
65 2 7/16, 2 1/2	22215	1600	2900	1300	1600	2400	1300
70 2 11/16, 2 3/4	22216	1500	2650	1200	1500	2200	1150
75 2 15/16, 3	22217	1400	2400	1100	1400	2000	1100
80 3 3/16, 3 1/4	22218	1400	2400	1000	1400	2000	1000
85 –	22219	1300	2200	1000	1300	1800	950
90 3 7/16, 3 1/2	22220	1200	2000	900	1200	1600	900
100 3 15/16, 4	22222	900	1700	600	900	1200	600
110 4 3/16, 4 1/4	22224	800	1600	500	800	1100	500
115 4 7/16, 4 1/2	22226	700	1500	400	700	1000	400
125 4 15/16, 5	22228	650	1200	350	650	900	350
135, 140 5 3/8, 5 7/16, 5 1/2	23132	-	-	-	-	750	500 ⁽²⁾
150 5 13/16, 5 7/8, 5 15/16, 6	23134	-	-	-	-	700	470 ⁽²⁾
160 6 5/16, 6 3/8, 6 7/16, 6 1/2	23136	-	-	-	-	650	430 ⁽²⁾
170 6 13/16, 6 7/8, 6 15/16, 7	23138	-	-	-	-	600	400 ⁽²⁾
180 7 1/8, 7 3/16, 7 1/4	23140	-	-	-	-	600	400 ⁽²⁾
200 7 13/16, 7 7/8, 7 15/16, 8	23144	-	-	-	-	500	330 ⁽²⁾
220 8 7/16, 8 1/2, 8 15/16, 9	23148	-	-	-	-	470	310 ⁽²⁾
240 9 7/16, 9 1/2	23152	-	-	-	-	380	250 ⁽²⁾
260 9 15/16, 10, 10 7/16, 10 1/2	23156	-	-	-	-	360	240 ⁽²⁾
280 10 15/16, 11	23160	-	-	-	-	320	210 ⁽²⁾
300 11 7/16, 11 1/2, 11 15/16, 12	23164	-	-	-	-	290	190 ⁽²⁾
320 12 7/16, 12 1/2	23168	-	-	-	-	270	180 ⁽²⁾
340 12 15/16, 13, 13 7/16, 13 1/2	23172	-	-	-	-	250	170 ⁽²⁾
360 13 15/16, 14	23176	-	-	-	-	240	160 ⁽²⁾
380 14 15/16, 15	23180	-	-	-	-	230	150 ⁽²⁾

⁽¹⁾Bearings with contact seals will have higher operating temperatures than bearings with labyrinth seals.

⁽²⁾Only available in O seal.

SEAL MATERIAL CHEMICAL COMPATIBILITY

A - Little to no effect B - Minor to moderate effect C - Severe effect to destruction N - No data – test prior to use.	Urethane	Nitrile Rubber	Viton	DuPont Teflon
Acetaldehyde	C	C	C	A
Acetamide	N	A	B	A
Acetic Acid	C	B	B	A
Acetic Anhydride	C	C	C	A
Acetone	C	C	C	A
Acetyl Bromide	C	N	N	N
Acetyl Chloride	C	C	A	A
Acetylene	C	A	A	A
Adipic Acid	A	A	N	A
Aero Shell Grease	B	A-B	A	A
Aero Lubriplate	A	A	A	A
Aero Safe 2300	N	C	C	A
Aerzine 50	N	C	C	A
Aluminum Acetate	N	A	C	A
Aluminum Bromide	N	A	A	A
Aluminum Chloride	B	A	A	A
Aluminum Sulfate	B	A	A	A
Ammonia	B	B	C	A
Ammonium Carbonate	B	C	N	A
Ammonium Chloride	N	A	A	A
Ammonium Hydroxide	B	C	A	A
Ammonium Nitrate	B	A	N	A
Ammonium Persulfate	B	C	N	A
Ammonium Sulfate	B	A	C	A
Ammonium Sulfide	B	A	C	A
Ammonium Thiocyanate	B	N	N	A
Ammonium Acetate	C	N	N	A
Amyl Acetate	C	C	C	A
Amyl Alcohol	C	B	C	A
Aniline	C	C	C	A
Aniline Hydrochloride	C	B	B	B
Animal Fats and Oils	B	A	A	A
Antimony Salts	B	N	N	A
Aqua Regia	C	C	B	A
Arsenic Salts	B	N	N	A
ASTM Oil #1	A	A	A	A
ASTM Oil #2	B	A	A	A
ASTM Oil #3	B	A	A	A
ASTM Reference Fuel A	A	A	A	A
ASTM Reference Fuel B	B	B	A	A
Atlantic Oil	A	A	A	A
Barium Carbonate	B	A	A	A
Barium Hydroxide	A	A	A	A
Beer	A	A	A	A
Benzaldehyde	B	C	C	A
Benzene	C	C	B	A
Benzoic Acid	B	C	A	A
Black Sulphate Liquors	N	B	A	A

A - Little to no effect B - Minor to moderate effect C - Severe effect to destruction N - No data – test prior to use.	Urethane	Nitrile Rubber	Viton	DuPont Teflon
Bleach Solutions	N	C	A	B
Boric Acid	A	A	A	A
Brake Fluid	N	C	C	N
Bromine	B	C	A	C
Bunker Oil	A	A	A	A
Butane	A	A	A	A
Butyl Acetate	C	C	C	A
Butyl Alcohol	B	A	A	A
Calcium Carbonate	B	A	A	A
Calcium Chloride	A	A	A	A
Calcium Hydroxide	A	A	A	A
Calcium Nitrate	B	A	A	A
Calcium Sulfate	B	B	B	A
Carbon Dioxide	A	A	A	A
Carbon Disulfide	B	C	A	A
Carbon Monoxide	A	A	A	A
Carbon Tetrachloride	C	C	A	A
Chlorine	N	C	A	B
Chloroacetic Acid	C	C	C	N
Chloroform	C	N	N	B
Chromic Acid	C	C	A	B
Chromium Potassium Sulfate	A	N	N	N
Citric Acid	B	A	A	A
Corn Oil	A	A	A	A
Cottonseed Oil	A	A	A	A
Cresol	C	C	A	A
Crude Oil	B	B	A	A
Cupric Chloride	A	B	B	A
Cupric Nitrate	B	N	N	A
Cupric Sulfate	B	B	B	A
Cutting Oil	B	A	A	A
Cyclohexane	B	A	A	A
Cyclohexanone	C	C	A	A
Dibutyl Phthalate	C	C	C	B
Dichlorobenzene	C	N	N	B
Diesel Fuel	B	A	A	A
Diester Oil	B	B	A	A
Dimethyl Acetamide	C	N	N	A
Dimethyl Formamide	C	B	C	A
Dodecyl Mercaptan	B	N	N	N
DTE Oil	B	A	N	N
Dubutyl Ether	B	C	C	N
EP Lubes	A	A	A	A
Esso #90 Lube Oil	A	A	A	A
Ether	B	N	N	A
Ethyl Acetate	C	C	C	A
Ethyl Alcohol (Ethanol)	C	A	C	A
Formic Acid	C	B	C	A

DISCLAIMER: Every reasonable effort has been made to ensure the accuracy of the information in this writing, but no liability is accepted for errors, omissions or for any other reason.

Continued on next page.

SEAL AND COVER OPTIONS • SEAL MATERIAL CHEMICAL COMPATIBILITY

Continued from previous page.

A - Little to no effect B - Minor to moderate effect C - Severe effect to destruction N - No data – test prior to use.	Urethane	Nitrile Rubber	Viton	DuPont Teflon
Freon, 12 or 113	A	A	B	A
Fuel Oil	B	A	A	A
Gasoline	B	B	A	A
Glucose	A	A	A	A
Glue	N	A	A	A
Glycerin	A	A	A	A
Heptane	A	N	N	A
Hexane	A	A	A	A
Hydrazine	C	B	C	B
Hydrobromic Acid	B	C	A	A
Hydrocarbon Oil	A	A	A	A
Hydrochloric Acid	B	C	B	A
Hydrofluoric Acid	B	C	C	A
Hydrogen	A	A	A	A
Hydrogen Peroxide	B	C	A	B
Hydrogen Sulfide	C	C	C	A
Hydrologic Acid	B	N	N	N
Iodine	A	B	A	A
Isobutyl Alcohol	N	B	A	A
Isopropyl Chloride	N	C	A	A
Isopropyl Ether	B	B	C	N
Isopropyl Alcohol (Propanol)	B	A	A	N
JP4 Oil	B	A	A	A
JP5 and 6 Oil	C	A	A	A
Kerosene	B	A	A	A
Lactic Acid	B	B	A	A
Lead Acetate	B	B	C	A
Linseed Oil	B	A	A	A
Liquefied Petroleum Gas	A	A	A	N
Lubrication Oil	B	A	A	A
Lye	N	B	B	A
Magnesium Chloride	N	A	A	A
Magnesium Hydroxide	A	B	A	A
Magnesium Salts	B	A	A	A
Maleic Acid	C	C	A	A
Mercury	B	A	A	A
Methyl Alcohol (Methanol)	A	C	A	N
Methyl Ethyl Ketone	C	C	C	A
Methylene Chloride	C	C	B	A
MIL-D-5606 Oil	C	A	A	A
MIL-L7808 Oil	B	B	A	A
Mineral Oil	A	A	A	A
Mineral Spirits	N	B	A	A
Naphthalene	B	C	A	A
Natural Gas	B	A	A	A
Nickel Salts	C	A	A	A
Oxygen	A	B	A	A
Ozone	A	C	A	A

A - Little to no effect B - Minor to moderate effect C - Severe effect to destruction N - No data – test prior to use.	Urethane	Nitrile Rubber	Viton	DuPont Teflon
Palmitic Acid	A	A	A	A
Paint Thinner	B	C	B	A
Peanut Oil	A	A	A	A
Perchloric Acid	C	C	A	A
Perchloroethylene	C	B	A	A
Petroleum	B	A	A	A
Phenol (Carbolic Acid)	C	C	A	A
Phosphoric Acid	C	C	A	A
Potassium Cyanide	A	A	A	A
Potassium Salts	B	A	A	A
Propane	B	A	A	A
Propyl Alcohol	B	A	A	A
Propylene Glycol	B	N	N	A
Pydraul Oil	C	C	A	A
SAE #10 Oil	A	A	A	A
Seawater	A	A	A	A
Silicic Acid	B	N	N	A
Silver Nitrate	B	B	A	A
Skydrol Oil	C	C	C	A
Soap	B	A	A	A
Sodium Acetate	A	B	C	A
Sodium Bicarbonate	B	A	A	A
Sodium Borate	B	A	A	A
Sodium Carbonate	B	A	A	A
Sodium Chloride	B	A	A	A
Sodium Cyanide	B	A	A	A
Sodium Hydrosulfite	B	N	N	A
Sodium Hydroxide	B	B	B	A
Sodium Hypochlorite	C	B	A	A
Sodium Nitrate	B	B	N	A
Sodium Silicate	A	A	A	A
Sodium Sulfate	B	A	A	A
Sodium Sulfide	B	A	A	A
Steam	C	C	C	A
Styrene	B	C	B	A
Sulfur Dioxide	B	C	A	A
Sulfuric Acid	C	C	A	A
Tannic Acid	A	A	A	A
Tartaric Acid	A	A	A	A
Toluene	C	N	N	A
Transformer Oil	B	N	N	A
Turpentine	C	A	A	A
Urea	B	N	N	A
Varnish	B	B	A	A
Water	B	A	A	A

DISCLAIMER: Every reasonable effort has been made to ensure the accuracy of the information in this writing, but no liability is accepted for errors, omissions or for any other reason.

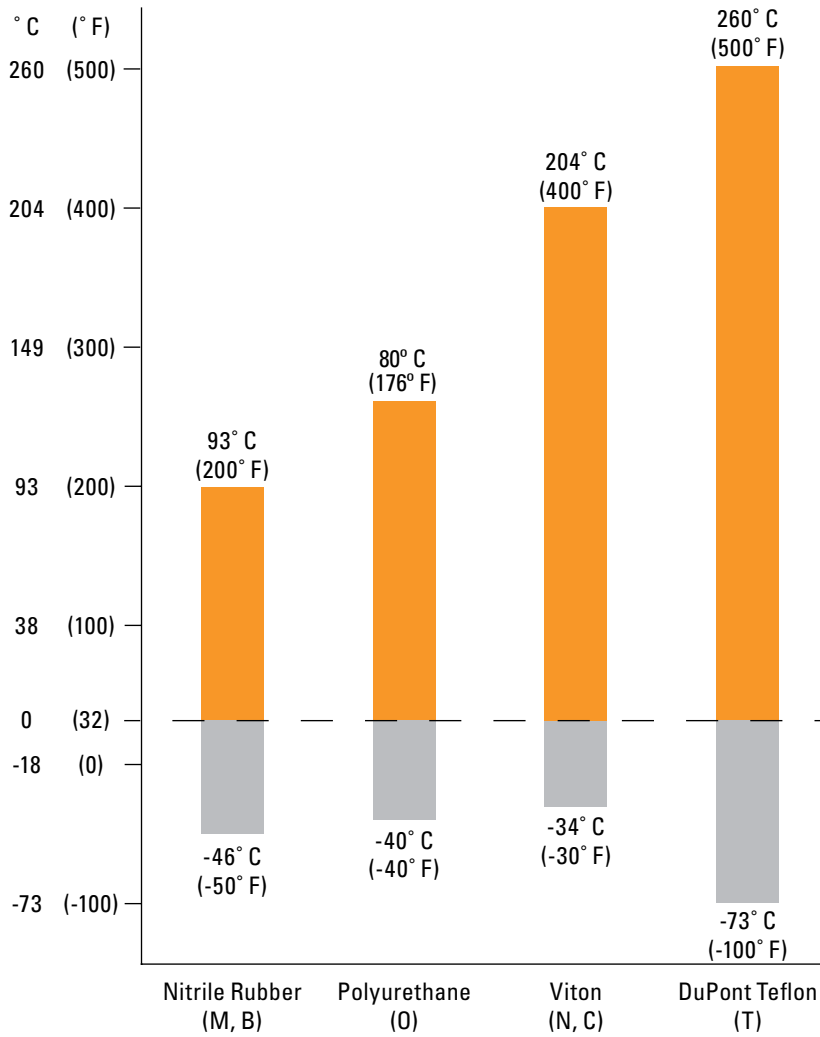

Fig. 33. Seal temperature ratings based on analytics.

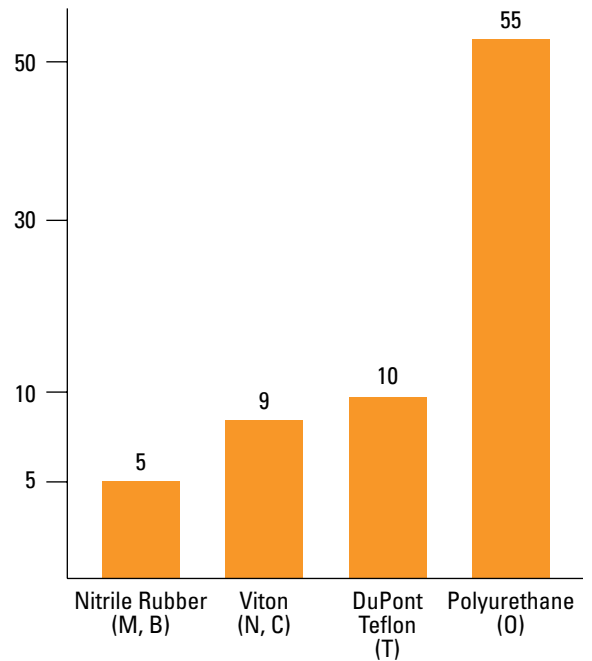

Fig. 34. Relative abrasion resistance ratings.

INTERNAL RADIAL CLEARANCES

TABLE 36. V-LOCK SERIES (TAPERED BORE, C3)

Shaft Dia.	Bearing No.	Clearance		Minimum Permissible RIC After Installation
		Min.	Max.	
mm in.		mm in.	mm in.	mm in.
50 1 15/16, 2	22211	0.075 0.0030	0.095 0.0037	0.038 0.0015
55 2 3/16, 2 1/4	22212	0.075 0.0030	0.095 0.0037	0.038 0.0015
55 2 3/16, 2 1/4	22213	0.075 0.0030	0.095 0.0037	0.038 0.0015
60, 65 2 7/16, 2 1/2	22214	0.094 0.0037	0.119 0.0047	0.043 0.0017
60, 65 2 7/16, 2 1/2	22215	0.094 0.0037	0.119 0.0047	0.043 0.0017
70, 75 2 11/16, 2 3/4, 2 15/16, 3	22216	0.094 0.0037	0.119 0.0047	0.049 0.0017
70, 75 2 11/16, 2 3/4, 2 15/16, 3	22217	0.109 0.0043	0.140 0.0055	0.051 0.0020
80, 85, 90 3 3/16, 3 1/4, 3 7/16, 3 1/2	22219	0.109 0.0043	0.140 0.0055	0.051 0.0020
80, 85, 90 3 3/16, 3 1/4, 3 7/16, 3 1/2	22220	0.109 0.0043	0.140 0.0055	0.051 0.0020
100 3 11/16, 3 3/4, 3 15/16, 4	22222	0.135 0.0053	0.170 0.0067	0.064 0.0025
110 —	22224	0.135 0.0053	0.170 0.0067	0.064 0.0025
110, 115 4 7/16, 4 1/2	22226	0.160 0.0063	0.201 0.0079	0.076 0.0030
125, 130 4 15/16, 5	22228	0.160 0.0063	0.201 0.0079	0.076 0.0030

TABLE 37. CL SERIES (STRAIGHT BORE, C NORMAL)

Shaft Dia.	Bearing No.	Clearance	
		Min.	Max.
mm in.		mm in.	mm in.
35 1 7/16, 1 1/2	22208	0.030 0.0012	0.045 0.0018
40, 45 1 11/16, 1 3/4	22209	0.035 0.0014	0.055 0.0022
50 1 15/16, 2	22210	0.040 0.0016	0.065 0.0026
55 2 3/16, 2 1/4	22211	0.040 0.0016	0.065 0.0026
60, 65 2 7/16, 2 1/2	22213	0.040 0.0016	0.065 0.0026
70, 75 2 11/16, 2 3/4, 2 15/16, 3	22215	0.050 0.002	0.080 0.0031
80, 85, 90 3 3/16, 3 1/4, 3 7/16, 3 1/2	22218	0.060 0.0024	0.100 0.0039
100 3 15/16, 4	22220	0.075 0.003	0.120 0.0047
110, 115 4 7/16, 4 1/2	22222	0.075 0.003	0.120 0.0047
125, 130 4 15/16, 5	22226	0.095 0.0037	0.145 0.0057

TABLE 38. EC SERIES (STRAIGHT BORE, C NORMAL)

Shaft Dia.	Bearing No.	Clearance		Shaft Dia.	Bearing No.	Clearance	
		Min.	Max.			Min.	Max.
mm in.		mm in.	mm in.	mm in.		mm in.	mm in.
35 1 7/16, 1 1/2	22208	0.030 0.0012	0.045 0.0018	80, 85, 90 3 3/16, 3 1/4 3 7/16, 3 1/2	22218	0.060 0.0024	0.100 0.0039
40, 45 1 11/16, 1 3/4	22209	0.0350 0.0014	0.055 0.0022	100 3 11/16, 3 3/4 3 15/16, 4	22220	0.075 0.003	0.120 0.0047
50 1 15/16, 2	22210	0.040 0.0016	0.065 0.0026	110, 115 4 7/16, 4 1/2	22222	0.075 0.003	0.120 0.0047
55 2 3/16, 2 1/4	22211	0.040 0.0016	0.065 0.0026	125, 130 4 15/16, 5	22226	0.095 0.0037	0.145 0.0057
60, 65 2 7/16, 2 1/2	22213	0.040 0.0016	0.065 0.0026	140, 150 5 7/16, 5 1/2 5 15/16, 6	23230	0.110 0.0043	0.170 0.0067
70, 75 2 11/16, 2 3/4 2 15/16, 3	22215	0.050 0.002	0.080 0.0031	170, 180 6 7/16, 6 1/2, 6 15/16, 7	23234	0.120 0.0047	0.180 0.0071

INTERNAL RADIAL CLEARANCES – continued

TABLE 39. TA (TAPERED BORE, C3)

Shaft Dia.	Bearing No.	Clearance Prior To Installation		Recommended Reduction Of Internal Radial Clearance		Recommended Axial Movement Of Adapter Sleeve		Minimum Internal Radial Clearance
		Min.	Max.	Min.	Max.	Min.	Max.	
mm in.		mm in.	mm in.	mm in.	mm in.	mm in.	mm in.	mm in.
40 1 7/16, 1 1/2	22209	0.061 0.0024	0.079 0.0031	0.025 0.0010	0.030 0.0012	0.381 0.015	0.457 0.018	0.030 0.0012
45 1 11/16, 1 3/4	22210	0.061 0.0024	0.079 0.0031	0.025 0.0010	0.030 0.0012	0.381 0.015	0.457 0.018	0.030 0.0012
50 1 15/16, 2	22211	0.076 0.0030	0.094 0.0037	0.030 0.0012	0.038 0.0015	0.457 0.018	0.559 0.022	0.038 0.0015
55 –	22212	0.076 0.0030	0.094 0.0037	0.030 0.0012	0.038 0.0015	0.457 0.018	0.559 0.022	0.038 0.0015
60 2 3/16, 2 1/4	22213	0.076 0.0030	0.094 0.0037	0.030 0.0012	0.038 0.0015	0.457 0.018	0.559 0.022	0.038 0.0015
65 2 7/16, 2 1/2	22215	0.094 0.0037	0.119 0.0047	0.038 0.0015	0.051 0.0020	0.559 0.022	0.762 0.030	0.043 0.0017
70 2 11/16, 2 3/4	22216	0.094 0.0037	0.119 0.0047	0.038 0.0015	0.051 0.0020	0.559 0.022	0.762 0.030	0.043 0.0017
75 2 15/16, 3	22217	0.109 0.0043	0.140 0.0055	0.046 0.0018	0.064 0.0025	0.686 0.027	0.965 0.038	0.051 0.0020
80 3 3/16, 3 1/4	22218	0.109 0.0043	0.140 0.0055	0.046 0.0018	0.064 0.0025	0.686 0.027	0.965 0.038	0.051 0.0020
85 –	22219	0.109 0.0043	0.140 0.0055	0.046 0.0018	0.064 0.0025	0.686 0.027	0.965 0.038	0.051 0.0020
90 3 7/16, 3 1/2	22220	0.109 0.0043	0.140 0.0055	0.046 0.0018	0.064 0.0025	0.686 0.027	0.965 0.038	0.051 0.0020
100 3 15/16, 4	22222	0.135 0.0053	0.170 0.0067	0.051 0.0020	0.071 0.0028	0.762 0.030	1.067 0.042	0.064 0.0025
110 4 3/16, 4 1/4	22224	0.135 0.0053	0.170 0.0067	0.051 0.0020	0.071 0.0028	0.762 0.030	1.067 0.042	0.064 0.0025
115 4 7/16, 4 1/2	22226	0.160 0.0063	0.201 0.0079	0.064 0.0025	0.089 0.0035	0.889 0.035	1.270 0.050	0.076 0.0030
125 4 15/16, 5	22228	0.160 0.0063	0.201 0.0079	0.064 0.0025	0.089 0.0035	0.889 0.035	1.270 0.050	0.076 0.0030
135, 140 5 3/8, 5 7/16, 5 1/2	23132	0.180 0.0071	0.231 0.0091	0.076 0.0030	0.102 0.0040	1.255 0.04939	1.671 0.06578	0.076 0.0030
150 5 13/16, 5 7/8, 5 15/16, 6	23134	0.201 0.0079	0.259 0.0102	0.076 0.0030	0.114 0.0045	1.255 0.04939	1.816 0.07150	0.089 0.0035
160 6 5/16, 6 3/8, 6 7/16, 6 1/2	23136	0.201 0.0079	0.259 0.0102	0.076 0.0030	0.114 0.0045	1.255 0.04939	1.816 0.07150	0.089 0.0035
170 6 13/16, 6 7/8, 6 15/16, 7	23138	0.221 0.0087	0.290 0.0114	0.089 0.0035	0.127 0.0050	1.539 0.06061	2.090 0.08228	0.102 0.0040
180 7 1/8, 7 3/16, 7 1/4	23140	0.221 0.0087	0.290 0.0114	0.089 0.0035	0.127 0.0050	1.539 0.06061	2.090 0.08228	0.102 0.0040
200 7 13/16, 7 7/8, 7 15/16, 8	23144	0.249 0.0098	0.320 0.0126	0.102 0.0040	0.140 0.0055	1.671 0.06578	2.232 0.08789	0.114 0.0045
220 8 7/16, 8 1/2, 8 15/16, 9	23148	0.269 0.0106	0.351 0.0138	0.114 0.0045	0.152 0.0060	1.959 0.07711	2.520 0.09922	0.114 0.0045
240 9 7/16, 9 1/2	23152	0.300 0.0118	0.391 0.0154	0.114 0.0045	0.165 0.0065	1.959 0.07711	2.794 0.11000	0.140 0.0055
260 9 15/16, 10, 10 7/16, 10 1/2	23156	0.300 0.0118	0.391 0.0154	0.114 0.0045	0.165 0.0065	1.959 0.07711	2.794 0.11000	0.140 0.0055
280 10 15/16, 11	23160	0.330 0.0130	0.429 0.0169	0.127 0.0050	0.178 0.0070	2.090 0.08228	2.936 0.11561	0.152 0.0060
300 11 7/16, 11 1/2, 11 15/16, 12	23164	0.361 0.0142	0.470 0.0185	0.140 0.0055	0.191 0.0075	2.232 0.08789	3.068 0.12078	0.165 0.0065
320 12 7/16, 12 1/2	23168	0.361 0.0142	0.470 0.0185	0.140 0.0055	0.191 0.0075	2.232 0.08789	3.068 0.12078	0.165 0.0065
340 12 15/16, 13, 13 7/16, 13 1/2	23172	0.399 0.0157	0.521 0.0205	0.152 0.0060	0.203 0.0080	2.520 0.09922	3.356 0.13211	0.191 0.0075
360 13 15/16, 14	23176	0.399 0.0157	0.521 0.0205	0.152 0.0060	0.203 0.0080	2.520 0.09922	3.356 0.13211	0.191 0.0075
380 14 15/16, 15	23180	0.399 0.0157	0.521 0.0205	0.152 0.0060	0.203 0.0080	2.520 0.09922	3.356 0.13211	0.191 0.0075

SHAFTING

When installing and using housed unit bearings, all shafting should be straight, clean, free from burrs and within the recommended shaft tolerances in tables 40 and 41. For applications that involve high speed or extreme vibration conditions, we recommend that all shafting be machined to one-half the recommended tolerances below.

SHAFT EXPANSION

Steel expands or contracts 0.0000113 millimeters per millimeter for each degree Celsius (0.0000063 inches per inch for each degree Fahrenheit) relative temperature increase or decrease respectively. Expansion bearings are used to accommodate thermal expansion of steel. Where the shafting and the framework on which the bearings and shafting are mounted are made from

steel, the relative difference in expansion between the shaft and the framework will be minimal. In these conditions, fixed bearings can be used on both ends of the shaft. However, if there is a difference in material between the shaft and the framework, or if the application involves different temperatures from the shaft to the frame, then only one fixed bearing should be used on each shaft. All other bearings on the same shaft should be converted to floating to accommodate thermal expansion of the shaft.

**TABLE 40. V-LOCK, CL AND EC SERIES –
RECOMMENDED SHAFT TOLERANCES**

Shaft Dia.	Shaft Tolerance
mm in.	mm in.
35 1 ⁷ / ₁₆ , 1 ¹ / ₂	+0.00/-0.025 +0.00/-0.0010
40, 45 1 ¹ / ₁₆ , 1 ³ / ₄	+0.00/-0.038 + 0.00/-0.0015
50 1 ¹⁵ / ₁₆ , 2	+0.00/-0.038 + 0.00/-0.0015
55 2 ³ / ₁₆ , 2 ¹ / ₄	+0.00/-0.038 + 0.00/-0.0015
60, 65 2 ⁷ / ₁₆ , 2 ¹ / ₂	+0.00/-0.038 + 0.00/-0.0015
70, 75 2 ¹ / ₁₆ , 2 ³ / ₄ , 2 ¹⁵ / ₁₆ , 3	+0.00/-0.051 + 0.00/-0.0020
80, 85, 90 3 ³ / ₁₆ , 3 ¹ / ₄ , 3 ⁷ / ₁₆ , 3 ¹ / ₂	+0.00/-0.076 + 0.00/-0.0030
100 3 ¹ / ₁₆ , 3 ³ / ₄ , 3 ¹⁵ / ₁₆ , 4	+0.00/-0.076 + 0.00/-0.0030
110, 115 4 ⁷ / ₁₆ , 4 ¹ / ₂	+0.00/-0.127 + 0.00/-0.0050
125, 130 4 ¹⁵ / ₁₆ , 5	+0.00/-0.127 + 0.00/-0.0050
140, 150 5 ⁷ / ₁₆ , 5 ¹ / ₂ , 5 ¹⁵ / ₁₆ , 6	+0.00/-0.127 + 0.00/-0.0050
170, 180 6 ⁷ / ₁₆ , 6 ¹ / ₂ , 6 ¹⁵ / ₁₆ , 7	+0.00/-0.127 + 0.00/-0.0050

SHAFT TOLERANCES

TABLE 41. TA/DV TAA/DVV RECOMMENDED SHAFT TOLERANCES

Shaft Dia.		Shaft Tolerance		Shaft Dia.		Shaft Tolerance	
mm	in.	mm	in.	mm	in.	mm	in.
40		+0.00/-0.025		135, 140		+0.00/-0.127	
1 7/16, 1 1/2		+0.00/-0.0010		5 3/8, 5 7/16, 5 1/2		+0.00/-0.0050	
45		+0.00/-0.051		150		+0.00/-0.127	
1 11/16, 1 3/4		+0.00/-0.0020		5 13/16, 5 7/8, 5 15/16, 6		+0.00/-0.0050	
50		+0.00/-0.076		160		+0.00/-0.127	
1 15/16, 2		+0.00/-0.0030		6 5/16, 6 3/8, 6 7/16, 6 1/2		+0.00/-0.0050	
55		+0.00/-0.076		170		+0.00/-0.127	
—		—		6 13/16, 6 7/8, 6 15/16, 7		+0.00/-0.0050	
60		+0.00/-0.076		180		+0.00/-0.127	
2 3/16, 2 1/4		+0.00/-0.0030		7 1/8, 7 3/16, 7 1/4		+0.00/-0.0050	
65		+0.00/-0.089		200		+0.00/-0.127	
2 7/16, 2 1/2		+0.00/-0.0035		7 13/16, 7 7/8, 7 15/16, 8		+0.00/-0.0050	
70		+0.00/-0.102		220		+0.00/-0.152	
2 11/16, 2 3/4		+0.00/-0.0040		8 7/16, 8 1/2, 8 15/16, 9		+0.00/-0.0060	
75		+0.00/-0.102		240		+0.00/-0.152	
2 15/16, 3		+0.00/-0.0040		9 7/16, 9 1/2		+0.00/-0.0060	
80		+0.00/-0.102		260		+0.00/-0.152	
3 3/16, 3 1/4		+0.00/-0.0040		9 15/16, 10, 10 7/16, 10 1/2		+0.00/-0.0060	
85		+0.00/-0.102		280		+0.00/-0.178	
—		—		10 15/16, 11		+0.00/-0.0070	
90		+0.00/-0.102		300		+0.00/-0.178	
3 7/16, 3 1/2		+0.00/-0.0040		11 7/16, 11 1/2, 11 15/16, 12		+0.00/-0.0070	
100		+0.00/-0.102		320		+0.00/-0.203	
3 15/16, 4		+0.00/-0.0040		12 7/16, 12 1/2		+0.00/-0.0080	
110		+0.00/-0.102		340		+0.00/-0.203	
4 3/16, 4 1/4		+0.00/-0.0040		12 15/16, 13, 13 7/16, 13 1/2		+0.00/-0.0080	
115		+0.00/-0.102		360		+0.00/-0.203	
4 7/16, 4 1/2		+0.00/-0.0040		13 15/16, 14		+0.00/-0.0080	
125		+0.00/-0.127		380		+0.00/-0.203	
4 15/16, 5		+0.00/-0.0050		14 15/16, 15		+0.00/-0.0080	

CONVERSION FROM FIXED TO FLOATING

Housed unit bearings are easily converted from fixed to floating in the field (see the appropriate installation guide in this catalog for instructions). The following table will help you determine the amount of float for each bearing based on the number of revolutions the external housing nut is backed out.

TABLE 42. AMOUNT OF FLOAT PER ONE ROTATION OF EXTERNAL HOUSING NUT

Bearing Number	Float	Bearing Number	Float	Bearing Number	Float
	mm in.		mm in.		mm in.
22208	1.270 0.050	22220	2.108 0.083	23144	2 0.079
22209	1.270 0.050	22222	2.108 0.083	23148	2 0.079
22210	1.270 0.050	22224	2.108 0.083	23152	2 0.079
22211	1.270 0.050	22226	2.108 0.083	23156	2 0.079
22212	1.270 0.050	22228	2.108 0.083	23160	2 0.079
22213	2.108 0.083	23230	2.108 0.083	23164	2 0.079
22214	2.108 0.083	23234	2.108 0.083	23168	2 0.079
22215	2.108 0.083	23132	2 0.079	23172	2 0.079
22216	2.108 0.083	23134	2 0.079	23176	2 0.079
22217	2.108 0.083	23136	2 0.079	23180	2 0.079
22218	2.108 0.083	23138	2 0.079	-	-
22219	2.108 0.083	23140	2 0.079	-	-

LUBRICATION

Timken is dedicated to using the highest quality components in everything we do. This is why we use premium industrial grease in spherical roller bearing solid-block housed units. The lithium-complex extreme-pressure grease combines the benefits of wide operating temperatures and broad compatibility. This grease offers excellent thermal stability through temperatures ranging from -34° C to 177° C (-30° F to 350° F). When dealing with temperatures above 149° C (300° F), consult your Timken engineer for optional grease recommendations. Application-specific lubrication options are also available ranging from Timken Food Safe Grease (aluminum-complex) to Timken Mill grease (calcium-sulfonate) along with many others.

MISALIGNMENT

All spherical roller bearing housed units utilize self-aligning double-row spherical roller bearings. Because of this, the housed unit accommodates angular misalignment up to 1.5 degrees. The life performance of our housed unit is not reduced while under misalignment conditions within these guidelines. It will accept both radial and thrust loads under static, oscillatory or dynamic load conditions.

TABLE 43. MISALIGNMENT SCALE AT 1.5 DEGREES

A	B
m ft.	mm in.
0.305 1	7.981 0.314
1.524 5	39.905 1.570

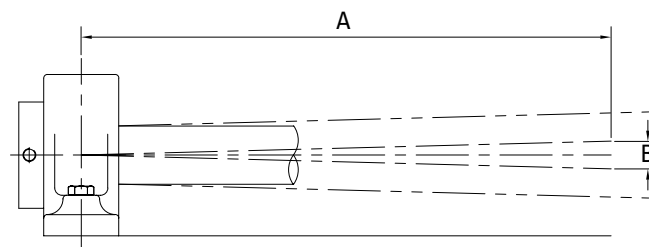

Fig. 35. Misalignment.

INSTALLATION GUIDES

V-LOCK SERIES

Timken® solid-block housed unit V-Lock bearings are easy to install and remove because of their unique adapters.

Please complete the following steps to install and/or remove Timken steel housed unit V-Lock bearings. Refer to fig. 36.

- Ensure that the shaft is clean, free from nicks and burrs, straight and of proper diameter. See table 45 for recommended shaft tolerances. The housed unit should not be mounted on a worn section of the shaft. Using shafts with hardness greater than HRC 45 will reduce the effectiveness of locking devices.
- If using an open-end cover, slide the open-end cover/seal combination into position on the shaft.
- Remove the wedge assembly from the sleeve by unscrewing the wedge nut. See fig. 36.
- Clean oil off of the sleeve and wedge.
- Apply a thin oil film to the shaft only.
 - For **QV** single-nut housed units:
 - Slide the sleeve, non-threaded end first, into position on the shaft.
 - For **QVV** double-nut housed units:
 - Make sure the sleeve nut is flush with the end of the sleeve.
 - Slide the sleeve/nut assembly, nut end first, into position on the shaft.
- Slide the housed unit into place over the sleeve.
- Loosely install the housed unit mounting bolts. Check the housed unit alignment. Verify that the mounting surfaces are in the same flat plane to help achieve good alignment. If shimming is required to minimize misalignment, use full shims across the entire housing base where possible (fig. 37). Washers should be properly sized to bolt diameter and should not be an SAE grade, which is smaller.
- Seat the sleeve as best as possible into the mounted unit.
- Tighten the wedge assembly by turning the wedge nut clockwise until tight. Please note that it is designed to prevent overtightening.
- If installing a double-nut housed unit, tighten the sleeve assembly by turning the sleeve nut clockwise until snug.
- Tighten both the wedge nut and sleeve nut set screws alternately according to fig. 36.
- Install the housed unit mounting bolts. Check the housed unit alignment. Verify that the mounting surfaces are in the same flat plane to achieve good alignment. If shimming is required to minimize misalignment, use full shims across the entire housing base where possible (fig. 37). The bolts then need to be alternately torqued securely to their mounting supports.
- Tighten the housing mounting bolts.

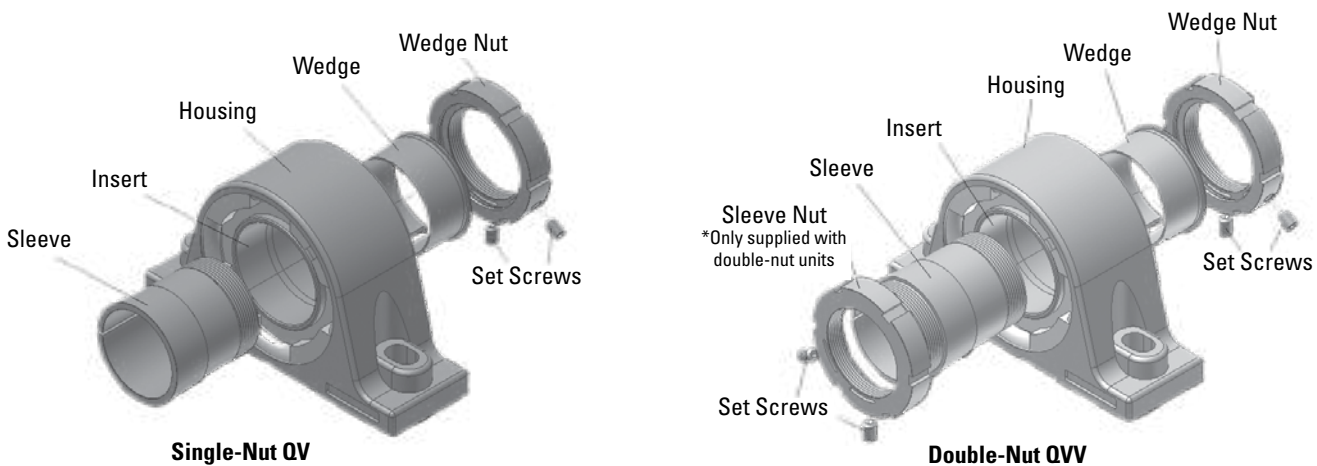

Fig. 36. V-Lock insert components.

TABLE 44. SET SCREW TORQUE VALUES

Shaft Dia.	Bearing No.	Set Screw Size	Torque
mm in.		mm in.	Nm in.-lbs.
50-90 1 15/16 - 3 1/2	SLV11 to SLV20	M10 X 1.5 3/8-24 TPI	32.8 290
100 3 11/16 - 4	SLV22	M12 X 1.75 7/16-20 TPI	47.5 420
110-130 4 7/16 - 5	SLV24 to SLV28	M12 X 1.75 1/2-20 TPI	70.1 620

If using covers:

- Make sure the mating surface of the cover and retaining nuts are clean and dry.
 - Urethane cover: Slightly roughen the mating surface of the cover, place a 3 mm – 6 mm (1/8 in. – 1/4 in.) bead of polyurethane adhesive sealant on the roughened surface.
 - Steel cover: Place a 3 mm – 6 mm (1/8 in. – 1/4 in.) bead of silicone adhesive sealant on the mating surface of the cover.
- Align the cover mounting holes with the mounting holes on the retaining housing nut (make sure that the grease fitting on the cover is accessible when doing so).
- Apply and tighten the cover mounting hardware.

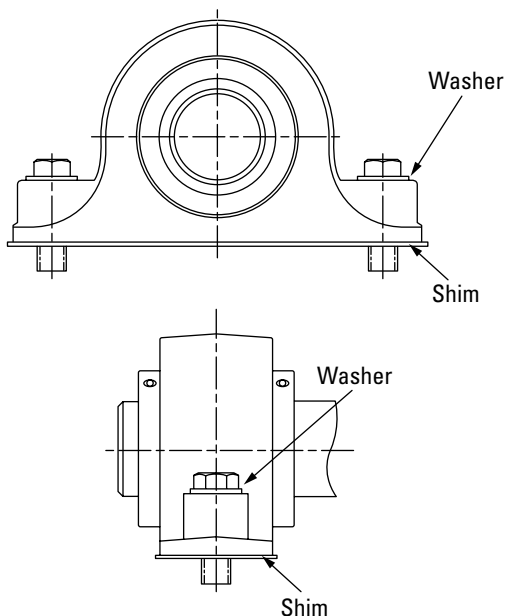

Fig. 37. Use washers and full shims.

REMOVAL

- Remove covers, if applicable, by removing cover hardware and disengaging the cover from the housed unit retaining nut.
- Loosen the set screws on the wedge nut.
- Turn the wedge nut counterclockwise to remove the wedge from the locked position.
- Completely remove the wedge/wedge nut assembly.
 - For **QV** housed units:
 - Remove the bearing and sleeve from the shaft.
 - For **QVV** housed units:
 - Loosen the set screws on the sleeve nut.
 - Turn the sleeve nut clockwise to un-seat the sleeve.
 - Remove the bearing and sleeve/sleeve nut from the shaft.

TABLE 45. RECOMMENDED SHAFT TOLERANCES

Shaft Dia.	Bearing No.	Tolerance
mm in.		mm in.
50 1 15/16, 2	22211	+0.00/-0.038 +0.00/-0.0015
55 2 3/16, 2 1/4	22212 22213	
60, 65 2 7/16, 2 1/2	22214 22215	
70, 75 2 11/16, 2 3/4, 2 15/16, 3	22216 22217	+0.00/-0.051 +0.00/-0.0020
80, 85, 90 3 3/16, 3 1/4, 3 7/16, 3 1/2	22219 22220	+0.00/-0.076 +0.00/-0.0030
100 3 11/16, 3 15/16, 4	22222	+0.00/-0.076 +0.00/-0.0030
110, 115 4 7/16, 4 1/2	22224 22226	+0.00/-0.127 +0.00/-0.0050
125, 130 4 15/16, 5	22228	

HOW TO CONVERT A SOLID-BLOCK HOUSED UNIT FROM FIXED TO EXPANSION (FLOATING)

Flange Cartridge and Flange Block

- Make a reference mark on the housing and retaining nut.
- Loosen the Nylon-tipped set screw that locks the retaining nut in place.
- Loosen the retaining nut by tapping it with a hammer and punch, rotating the retaining nut counterclockwise one complete revolution.
- Tighten the Nylon-tipped set screw.

Pillow Block

- Decide the amount and direction of expansion that's needed. If unidirectional expansion is required, follow the directions outlined in the previous page for flange housed units on the nut that is on the side you want the expansion.
- If multi-directional expansion is required, follow the directions outlined in the previous section for both nuts on flange housed units.

NOTE

When converting a solid-block housed unit bearing from fixed to expansion, it is imperative that the unit that is going to be converted is correctly oriented. Since the insert in a steel housed unit flange bearing is held against either a shoulder or snap ring opposite the housing retaining nut, a flange bearing that has been converted to expansion can only float in the direction of the retaining nut. Based on this, the retaining nut must be on the side of the housing opposite the fixed bearing.

HOW TO CONVERT A SOLID-BLOCK HOUSED UNIT FROM EXPANSION (FLOATING) TO FIXED

Flange Cartridge and Flange Block

- Loosen the Nylon-tipped set screw that locks the retaining nut in place.
- Tighten the retaining nut by tapping it with a hammer and punch, rotating the retaining nut clockwise until it's tight. It is not possible to overtighten the retaining nut.
- Tighten the Nylon-tipped set screw.

Pillow Block

- Follow the directions above for flange housed units on both nuts on either side of the housing.

NOTE

When converting a solid-block housed unit from expansion to fixed on a mounted bearing, the locking-collar set screws must be released to allow the insert to move both in the housing and on the shaft.



WARNING

Failure to observe the following warnings could create a risk of death or serious injury.

Proper maintenance and handling practices are critical. Always follow installation instructions and maintain proper lubrication.

Overheated bearings can ignite explosive atmospheres. Special care must be taken to properly select, install, maintain, and lubricate housed unit bearings that are used in or near atmospheres that may contain explosive levels of combustible gases or accumulations of dust such as from grain, coal, or other combustible materials. Consult your equipment designer or supplier for installation and maintenance instructions.

If hammer and bar are used for installation or removal of a part, use a mild steel bar (e.g., 1010 or 1020 grade). Mild steel bars are less likely to cause release of high speed fragments from the hammer or bar or the part being installed or removed.



CAUTION

Failure to follow these cautions may result in property damage.

Do not use damaged housed units.

LUBRICATION

This information is to aid in the proper lubrication of Timken spherical roller bearing solid-block housed units for the majority of applications.

Housed units have been factory-prelubricated with an NLGI No. 2 lithium-complex, extreme-pressure synthetic grease that combines the benefits of wide operating temperatures and broad compatibility with varied materials. This grease offers excellent thermal stability through temperatures ranging from -40° C to 177° C (-40° F to 350° F). Housed units should be relubricated with this grease or one that is compatible and made for roller bearings. It is vital that the greases used are compatible. Please consult

with your Timken engineer for the grease specifications if the use of a grease other than the grease mentioned above is needed.

Normal service is considered as operation in a clean, dry environment at temperatures between -34° C to +82° C (-30° F to +180° F). If service is beyond normal conditions due to speed, temperature, or exposure to moisture, dirt or corrosive chemicals, more frequent relubrication may be necessary. For extreme conditions or conditions in which special chemicals are used, consult with your Timken engineer.

After extended storage or periods when the housed unit is not in operation, fresh grease should be added.

It's important to have the right amount of lubrication, because it affects the housed unit bearing operating temperature as well. An inadequate amount of grease could lead to higher operating temperatures due to inadequate lubrication film thickness. Excessive grease also will lead to higher operating temperatures due to grease churning, which can cause bearing overheating. It is best to observe the bearing and its temperature and adjust the lubrication as needed. If necessary, use the purge valve or seals that purge to reduce the amount of grease.

NOTE

Please check with the manufacturer of your grease delivery system for specific information.

RELUBRICATION

Adequate lubrication is an essential element to the housed unit bearing life. Use table 46 as a suggested initial point of reference. Relubrication frequency and quantity intervals are best determined through experience for each application, based on types of service, which may differ from the suggestions in the table.

When the housed unit is not in operation for an extended period of time, grease should be added to prevent corrosion.

Table 46 shows general lubrication suggested starting points only. Please read the entire installation instructions prior to using these tables. Applications should be regularly reviewed and lubrication amounts and intervals modified as needed to ensure best results.

TABLE 46. RELUBRICATION INTERVALS

Shaft Diameter	Bearing No.	Initial Weight	Relubrication Weight	Relubrication Interval (Hours of Service based on RPM and Temperature deg. F)											
				100 RPM		250 RPM		500 RPM		1000 RPM		2000 RPM		3000 RPM	
				<160°	>160°	<160°	>160°	<160°	>160°	<160°	>160°	<160°	>160°	<160°	>160°
mm in.		g oz.	g oz.												
50 1 15/16, 2	22211	28.4 1	8.5 0.3	1200	600	800	400	440	220	160	80	100	50	60	30
55 2 3/16, 2 1/4	22212	34.0 1.2	8.5 0.3	1150	580	750	380	400	200	140	70	90	50	50	20
	22213	36.9 1.3	11.3 0.4	1130	570	740	370	380	190	130	65	85	45	45	20
60, 65 2 7/16, 2 1/2	22214	39.7 1.4	11.3 0.4	1120	560	720	360	360	180	120	60	80	40	40	20
	22215	56.7 2	14.2 0.5	1080	540	700	350	350	175	110	55	70	35		
70, 75 2 11/16, 2 3/4 2 15/16, 3	22216	76.5 2.7	19.9 0.7	1040	520	680	340	340	170	100	50	60	30		
	22217	96.4 3.4	25.5 0.9	1000	500	640	320	320	160	100	50	60	30		
80, 85, 90 3 3/16, 3 1/4 3 7/16, 3 1/2	22219	104.9 3.7	25.5 0.9	960	480	600	300	300	150	80	40	40	20		
	22220	184.3 6.5	45.4 1.6	840	420	520	260	240	120	70	35	30	18		
100 3 11/16, 3 3/4 3 15/16, 4	22222	209.8 7.4	53.9 1.9	680	340	440	220	200	100	60	30	20	16		
110, 115 4 7/16, 4 1/2	22224	260.8 9.2	68.0 2.4	640	320	400	200	180	90	50	25				
	22226	300.5 10.6	76.5 2.7	560	280	360	180	160	80						
125, 130 4 15/16, 5	22228	396.9 14	99.2 3.5	520	260	340	170	140	75						

DISCLAIMER: Every reasonable effort has been made to ensure the accuracy of the information in this writing, but no liability is accepted for errors, omissions or for any other reason.

CL SERIES

Please complete the following steps to install Timken solid-block housed unit CL series bearings.

- Ensure that the shaft is clean, free from nicks and burrs, straight and of proper diameter. See table 47 for recommended shaft tolerances. The housed unit should not be mounted on a worn section of the shaft. Using shafts with hardness greater than HRC 45 will reduce the effectiveness of locking devices.
- If using an open-end cover, slide the open-end cover/seal combination into position on the shaft.
- Apply a thin oil film to the shaft and bearing bore.
- Slide the housed unit into position on the shaft.
- Install the housed unit mounting bolts. Check the housed unit alignment. Verify mounting surfaces are in the same flat plane to help achieve good alignment. If shimming is required to minimize misalignment, use full shims across the entire housing base where possible (fig. 39). The bolts then need to be alternately torqued securely to their mounting supports.
- Tighten set screws alternately as per table 48. Set screws in multiple units should be aligned to each other (fig. 38).

If using covers:

- Make sure the mating surface of the cover and retaining nuts are clean and dry.
 - Urethane cover: slightly roughen the mating surface of the cover, place a 3 mm – 6 mm (1/8 in. – 1/4 in.) bead of polyurethane adhesive sealant on the roughened surface.
 - Steel cover: place a 3 mm – 6 mm (1/8 in. – 1/4 in.) bead of silicone adhesive sealant on the mating surface of the cover.
- Align the cover mounting holes with the mounting holes on the retaining housing nut (make sure that the grease fitting on the cover is accessible when doing so).
- Apply and tighten the cover mounting hardware.

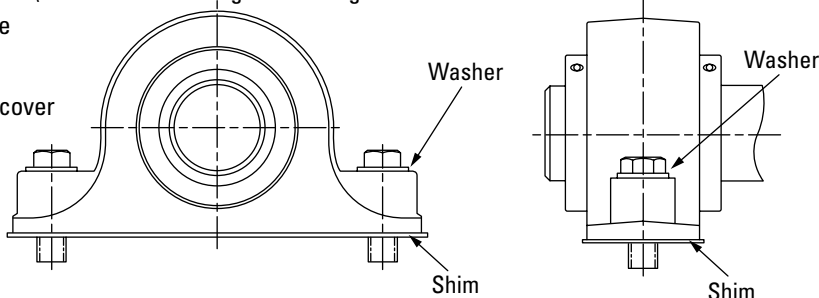

Fig. 39. Use washers and full shims.

TABLE 47. RECOMMENDED SHAFT TOLERANCES

Shaft Dia.	Bearing No.	Tolerance
mm in.		mm in.
35 1 7/16, 1 1/2	22208	+0.00/-0.025 +0.00/0.0010
40, 45 1 1/16, 1 3/4	22209	+0.00/-0.038 +0.00/0.0015
50 1 15/16, 2	22210	+0.00/-0.038 +0.00/-0.0015
55 2 3/16, 2 1/4	22211	+0.00/-0.038 +0.00/-0.0015
60, 65 2 7/16, 2 1/2	22213	+0.00/-0.038 +0.00/-0.0015
70, 75 2 11/16, 2 3/4 2 15/16, 3	22215	+0.00/-0.051 +0.00/-0.0020
80, 85, 90 3 3/16, 3 1/4 3 7/16, 3 1/2	22218	+0.00/-0.076 +0.00/-0.0030
100 3 15/16, 4	22220	+0.00/-0.076 +0.00/-0.0030
110, 115 4 7/16, 4 1/2	22222	+0.00/-0.127 +0.00/-0.0050
125, 130 4 15/16, 5	22226	+0.00/-0.127 +0.00/-0.0050

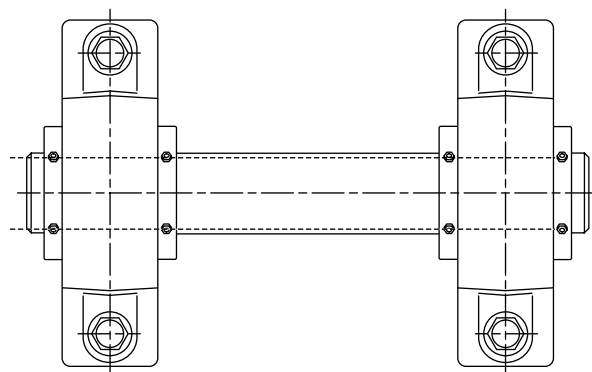

Fig. 38. Line up set screws in multiple units.

TABLE 48. SET SCREW TORQUE VALUES

Shaft Dia.	Bearing No.	Set Screw Size	Torque
mm in.		mm in.	Nm lbs.
35 1 7/16, 1 1/2	22208	M10 X 1.5 3/8 - 24 TPI	32.8 290
40, 45 1 11/16, 1 3/4	22209	M10 X 1.5 3/8 - 24 TPI	32.8 290
50 1 15/16, 2	22210	M10 X 1.5 3/8 - 24 TPI	32.8 290
55 2 3/16, 2 1/4	22211	M10 X 1.5 3/8 - 24 TPI	32.8 290
60, 65 2 7/16, 2 1/2	22213	M12 X 1.75 1/2 - 20 TPI	70.1 620
70, 75 2 11/16, 2 3/4 2 15/16, 3	22215	M12 X 1.75 1/2 - 20 TPI	70.1 620
80, 85, 90 3 3/16, 3 1/4 3 7/16, 3 1/2	22218	M12 X 1.75 1/2 - 20 TPI	70.1 620
100 3 15/16, 4	22220	M16 X 2 5/8 - 18 TPI	149.7 1325
110, 115 4 7/16, 4 1/2	22222	M16 X 2 5/8 - 18 TPI	149.7 1325
125, 130 4 15/16, 5	22226	M16 X 2 5/8 - 18 TPI	149.7 1325

LUBRICATION

This information is to aid in the proper lubrication of Timken spherical roller bearing solid-block housed units for the majority of applications.

Housed units have been factory-prelubricated with an NLGI No. 2 lithium-complex, extreme pressure synthetic grease that combines the benefits of wide operating temperatures and broad compatibility with varied materials. This grease offers excellent thermal stability through temperatures ranging from -40° C to 177° C (-40° F to 350° F). Housed units should be relubricated with this grease or one that is compatible and made for roller bearings. It is vital that the greases used are compatible. Please consult with your Timken engineer for the grease specifications if the use of a grease other than the grease mentioned above is needed.

Normal service is considered as operation in a clean, dry environment at temperatures between -34° C to +82° C (-30° F to +180° F). If service is beyond normal conditions due to speed, temperature, or exposure to moisture, dirt or corrosive chemicals, periodic relubrication may be necessary. For extreme conditions or conditions in which special chemicals are used, consult with your Timken engineer.

After extended storage or periods when the housed unit is not in operation, fresh grease should be added.

It is important to have the right amount of lubrication, because it affects the housed unit bearing operating temperature as well. An inadequate amount of grease could lead to higher operating temperatures due to inadequate lubrication film thickness. Excessive grease also will lead to higher operating temperatures due to grease churning, which can cause bearing overheating. It is best to observe the bearing and its temperature and adjust the lubrication as needed. If necessary, use the purge valve or seals that purge to reduce the amount of grease.

NOTE

Please check with the manufacturer of your grease delivery system for specific information.

WARNING

Failure to observe the following warnings could create a risk of death or serious injury.

Proper maintenance and handling practices are critical. Always follow installation instructions and maintain proper lubrication.

Overheated bearings can ignite explosive atmospheres. Special care must be taken to properly select, install, maintain, and lubricate housed unit bearings that are used in or near atmospheres that may contain explosive levels of combustible gases or accumulations of dust such as from grain, coal, or other combustible materials. Consult your equipment designer or supplier for installation and maintenance instructions.

If hammer and bar are used for installation or removal of a part, use a mild steel bar (e.g., 1010 or 1020 grade). Mild steel bars are less likely to cause release of high speed fragments from the hammer or bar or the part being installed or removed.

CAUTION

Failure to follow these cautions may result in property damage.

Do not use damaged housed units.

RELUBRICATION

Adequate lubrication is an essential element to the housed unit bearing life. Use table 49 as a suggested initial point of reference. Relubrication frequency and quantity intervals are best determined through experience for each application based on types of service, which may differ from the suggestions in the table.

When the housed unit is not in operation for an extended period of time, grease should be added to prevent corrosion.

Table 49 shows general lubrication suggested starting points only. Please read the entire installation instructions prior to using these tables. Applications should be regularly reviewed and lubrication amounts and intervals modified as needed to ensure the best results.

TABLE 49. RELUBRICATION INTERVALS

Shaft Dia.	Bearing No.	Initial Weight	Relubrication Weight	Relubrication Interval (Hours of Service based on RPM and Temperature deg. F)											
				100 RPM		250 RPM		500 RPM		1000 RPM		2000 RPM		3000 RPM	
				<160°	>160°	<160°	>160°	<160°	>160°	<160°	>160°	<160°	>160°	<160°	>160°
mm in.		g oz.	g oz.												
35 1 7/16, 1 1/2	22208	14.2 0.5	2.4 0.1	2200	1000	1400	700	1000	500	240	120	120	60	40	20
40, 45 1 11/16, 1 3/4	22209	19.9 0.7	5.7 0.2	2000	1000	1200	600	800	400	320	160	160	80	80	40
50 1 15/16, 2	22210	22.7 0.8	5.7 0.2	1600	800	1000	500	640	320	240	120	120	60	60	30
55 2 3/16, 2 1/4	22211	28.4 1	8.5 0.3	1200	600	800	400	440	220	160	80	100	50	60	30
60, 65 2 7/16, 2 1/2	22213	39.7 1.4	11.3 0.4	1120	560	720	360	360	180	120	60	80	40	40	20
70, 75 2 11/16, 2 3/4 2 15/16, 3	22215	76.5 2.7	19.4 0.7	1040	520	680	340	340	170	100	50	60	30		
80, 85, 90 3 3/16, 3 1/4 3 7/16, 3 1/2	22218	104.9 3.7	25.5 0.9	960	480	600	300	300	150	80	40	40	20		
100 3 15/16, 4	22220	184.3 6.5	45.4 1.6	840	420	520	260	240	120	60	30	20	16		
110, 115 4 7/16, 4 1/2	22222	209.8 7.4	53.9 1.9	680	340	440	220	200	100	60	30	20	16		
125, 130 4 15/16, 5	22226	300.5 10.6	76.5 2.7	560	280	360	180	160	80						

DISCLAIMER: Every reasonable effort has been made to ensure the accuracy of the information in this writing, but no liability is accepted for errors, omissions or for any other reason.

HOW TO CONVERT A SOLID-BLOCK HOUSED UNIT FROM FIXED TO EXPANSION (FLOATING)

Flange Cartridge and Flange Block

- Make a reference mark on the housing and retaining nut.
- Loosen the Nylon-tipped set screw that locks the retaining nut in place.
- Loosen the retaining nut by tapping it with a hammer and punch, rotating the retaining nut counterclockwise one complete revolution.
- Tighten the Nylon-tipped set screw.

NOTE

When converting a solid-block housed unit bearing from fixed to expansion, it is imperative that the unit that is going to be converted is correctly oriented. Since the insert in a steel housed unit flange bearing is held against either a shoulder or snap ring opposite the housing retaining nut, a flange bearing that has been converted to expansion can only float in the direction of the retaining nut. Based on this, the retaining nut must be on the side of the housing opposite the fixed bearing.

Pillow Block

- Decide the amount and direction of expansion that's needed. If unidirectional expansion is required, follow the directions outlined above for flange bearings on the nut that is on the side you want the expansion.
- If multi-directional expansion is required, follow the directions as outlined above for both nuts on flange housed units.

HOW TO CONVERT A SOLID-BLOCK HOUSED UNIT FROM EXPANSION (FLOATING) TO FIXED

Flange Cartridge and Flange Block

- Loosen the Nylon-tipped set screw that locks the retaining nut in place.
- Tighten the retaining nut by tapping it with a hammer and punch, rotating the retaining nut clockwise until it's tight. It is not possible to overtighten the retaining nut.
- Tighten the Nylon-tipped set screw.

Pillow Block

- Follow the directions above for flange bearings on both nuts on either side of the housing.

NOTE

When converting a solid-block housed unit from expansion to fixed on a mounted bearing, the locking-collar set screws must be released to allow the insert to move both in the housing and on the shaft.

EC SERIES

Please complete the following steps to install Timken EC series spherical roller bearing solid-block housed units.

- Ensure that the shaft is clean, free from nicks and burrs, straight and of proper diameter. See table 50 for recommended shaft tolerances. The housed unit should not be mounted on a worn section of the shaft. Using shafts with hardness greater than HRC 45 will reduce the effectiveness of locking devices.
- If using an open-end cover, slide the open-end cover/seal combination into position on the shaft.
- Apply a thin oil film to the shaft and bearing bore.
- Slide the housed unit into position on the shaft.
- Install the housed unit mounting bolts. Check the housed unit alignment. Verify that the mounting surfaces are in the same flat plane to help achieve good alignment. If shimming is required to minimize misalignment, use full shims across the entire housing base where possible (fig. 40). The bolts then need to be alternately torqued securely to their mounting supports.
- Slide the eccentric locking collar along shaft and onto the extended portion of the bearing's inner ring.
- Rotate the eccentric locking collar until it is hand-tight (the direction of rotation does not matter).
- Lock the eccentric locking collar firmly in place by using a spanner wrench or a hammer and drift.
 - When using a hammer and drift, one or two firm, but not too hard, blows will be sufficient due to the shallow eccentric ramp on EC series housed units. Make sure you drive the collar in the same direction in which you hand-tightened it so as to turn it to a tighter position on the bearing's inner ring.
- Tighten the eccentric locking collar set screws alternately as per table 51.

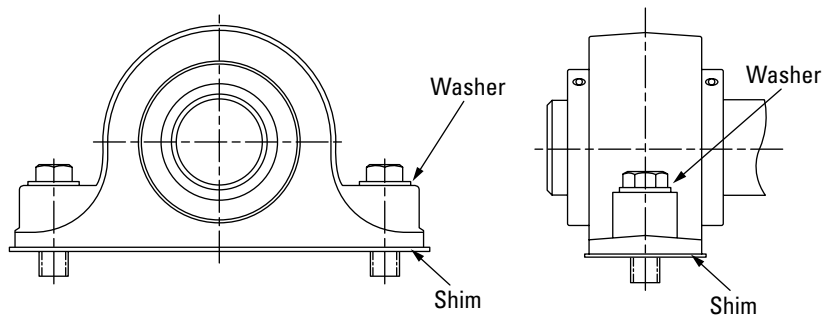

Fig. 40. Use washers and full shims.

If using covers:

- Make sure the mating surface of the cover and retaining nuts are clean and dry.
 - Urethane cover: Slightly roughen the mating surface of the cover, place a 3 mm – 6 mm (1/8 in. – 1/4 in.) bead of polyurethane adhesive sealant on the roughened surface.
 - Steel cover: Place a 3 mm – 6 mm (1/8 in. – 1/4 in.) bead of silicone adhesive sealant on the mating surface of

the cover.

- Align the cover mounting holes with the mounting holes on the retaining housing nut (make sure that the grease fitting on the cover is accessible when doing so).
- Apply and tighten the cover mounting hardware.

TABLE 50. RECOMMENDED SHAFT TOLERANCES

Shaft Dia.	Bearing No.	Tolerance
mm in.		mm in.
35 1 7/16, 1 1/2	22208	+0.00/-0.025 +0.00/-0.0010
40, 45 1 11/16, 1 3/4	22209	+0.00/-0.038 +0.00/-0.0015
50 1 15/16, 2	22210	+0.00/-0.038 +0.00/-0.0015
55 2 3/16, 2 1/4	22211	+0.00/-0.038 +0.00/-0.0015
60, 65 2 7/16, 2 1/2	22213	+0.00/-0.038 +0.00/-0.0015
70, 75 2 11/16, 2 3/4 2 15/16, 3	22215	+0.00/-0.051 +0.00/-0.0020
80, 85, 90 3 3/16, 3 1/4 3 7/16, 3 1/2	22218	+0.00/-0.076 +0.00/-0.0030
100 3 11/16, 3 3/4 3 15/16, 4	22220	+0.00/-0.076 +0.00/-0.0030
110, 115 4 7/16, 4 1/2	22222	+0.00/-0.127 +0.00/-0.0050
125, 130 4 15/16, 5	22226	+0.00/-0.127 +0.00/-0.0050
140, 150 5 7/16, 5 1/2 5 15/16, 6	23230	+0.00/-0.127 +0.00/-0.0050
170, 180 6 7/16, 6 1/2 6 15/16, 7	23234	+0.00/-0.127 +0.00/-0.0050

TABLE 51. SET SCREW TORQUE VALUES

Shaft Dia.	Bearing No.	Set Screw Size	Torque
mm in.		mm in.	Nm lbs.
35 1 7/16, 1 1/2	22208	M8 X 1.25 5/16 - 24 TPI	18.6 165
40, 45 1 11/16, 1 3/4	22209	M10 X 1.5 3/8 - 24 TPI	32.8 290
50 1 15/16, 2	22210	M10 X 1.5 3/8 - 24 TPI	32.8 290
55 2 3/16, 2 1/4	22211	M10 X 1.5 3/8 - 24 TPI	32.8 290
60, 65 2 7/16, 2 1/2	22213	M12 X 1.75 7/16 - 20 TPI	70.1 620
70, 75 2 11/16, 2 3/4 2 15/16, 3	22215	M12 X 1.75 7/16 - 20 TPI	70.1 620
80, 85, 90 3 3/16, 3 1/4 3 7/16, 3 1/2	22218	M12 X 1.75 7/16 - 20 TPI	70.1 620
100 3 11/16, 3 3/4 3 15/16, 4	22220	M16 X 2 5/8 - 18 TPI	149.7 1325
110, 115 4 7/16, 4 1/2	22222	M16 X 2 5/8 - 18 TPI	149.7 1325
125, 130 4 15/16, 5	22226	M16 X 2 5/8 - 18 TPI	149.7 1325
140, 150 5 7/16, 5 1/2 5 15/16, 6	23230	M16 X 2 5/8 - 18 TPI	149.7 1325
170, 180 6 7/16, 6 1/2 6 15/16, 7	23234	M16 X 2 5/8 - 18 TPI	149.7 1325

LUBRICATION

This information is to aid in the proper lubrication of Timken spherical roller bearing solid-block housed units for the majority of applications.

Housed units have been factory-prelubricated with an NLGI No. 2 lithium-complex, extreme-pressure synthetic grease that combines the benefits of wide operating temperatures and broad compatibility with varied materials. This grease offers excellent thermal stability through temperatures ranging from -40° C to 177° C (-40° F to 350° F). Housed units should be relubricated with this grease or one that is compatible and made for roller bearings. It is vital that the greases used are compatible. Please consult with your Timken engineer for the grease specifications if the use of a grease other than the grease mentioned above is needed.

Normal service is considered as operation in a clean, dry environment at temperatures between -34° C to +82° C (-30° F to +180° F). If service is beyond normal conditions due to speed, temperature, or exposure to moisture, dirt or corrosive chemicals, periodic relubrication may be necessary. For extreme conditions or conditions in which special chemicals are used, consult with your Timken engineer.

After extended storage or periods when the housed unit is not in operation, fresh grease should be added.

It's important to have the right amount of lubrication, because it affects the housed unit bearing operating temperature as well. An inadequate amount of grease could lead to higher operating temperatures due to inadequate lubrication film thickness. Excessive grease also will lead to higher operating temperatures due to grease churning, which can cause bearing overheating. It is best to observe the bearing and its temperature and adjust the lubrication as needed. If necessary, use the purge valve or seals that purge to reduce the amount of grease.

NOTE

Please check with the manufacturer of your grease delivery system for specific information.

RELUBRICATION

Adequate lubrication is an essential element to the housed unit bearing life. Use table 52 as a suggested initial point of reference. Relubrication frequency and quantity intervals are best developed through experience for each application based on types of service, which may differ from the suggestions in the table.

When the housed unit is not in operation for an extended period of time, grease should be added to prevent corrosion.

Table 52 shows general lubrication suggested starting points only. Please read the entire installation instructions prior to using these tables. Applications should be regularly reviewed and lubrication amounts and intervals modified as needed to ensure the best results.



WARNING

Failure to observe the following warnings could create a risk of death or serious injury.

Proper maintenance and handling practices are critical. Always follow installation instructions and maintain proper lubrication.

Overheated bearings can ignite explosive atmospheres. Special care must be taken to properly select, install, maintain, and lubricate housed unit bearings that are used in or near atmospheres that may contain explosive levels of combustible gases or accumulations of dust such as from grain, coal, or other combustible materials. Consult your equipment designer or supplier for installation and maintenance instructions.

If hammer and bar are used for installation or removal of a part, use a mild steel bar (e.g., 1010 or 1020 grade). Mild steel bars are less likely to cause release of high speed fragments from the hammer or bar or the part being installed or removed.



CAUTION

Failure to follow these cautions may result in property damage.

Do not use damaged housed units.

DISCLAIMER

Every reasonable effort has been made to ensure the accuracy of the information in this writing, but no liability is accepted for errors, omissions or for any other reason.

TABLE 52. RELUBRICATION INTERVALS

Shaft Dia.	Bearing No.	Initial Weight	Relubrication Weight	Relubrication Interval (Hours of Service based on RPM and Temperature deg. F)											
				100 RPM		250 RPM		500 RPM		1000 RPM		2000 RPM		3000 RPM	
				<160°	>160°	<160°	>160°	<160°	>160°	<160°	>160°	<160°	>160°	<160°	>160°
mm in.		g oz.	g oz.												
35 1 1/16, 1 1/2	22208	14.2 0.5	2.8 0.1	2200	1000	1400	700	1000	500	240	120	120	60	40	20
40, 45 1 1/16, 1 3/4	22209	19.9 0.7	5.7 0.2	2000	1000	1200	600	800	400	320	160	160	80	80	40
50 1 15/16, 2	22210	22.7 0.8	5.7 0.2	1600	800	1000	500	640	320	240	120	120	60	60	30
55 2 3/16, 2 1/4	22211	28.4 1	8.5 0.3	1200	600	800	400	440	220	160	80	100	50	60	30
60, 65 2 7/16, 2 1/2	22213	39.7 1.4	11.3 0.4	1120	560	720	360	360	180	120	60	80	40	40	20
70, 75 2 11/16, 2 3/4 2 15/16, 3	22215	76.5 2.7	19.8 0.7	1040	520	680	340	340	170	100	50	60	30		
80, 85, 90 3 3/16, 3 1/4 3 7/16, 3 1/2	22218	104.9 3.7	25.5 0.9	960	480	600	300	300	150	80	40	40	20		
100 3 11/16, 3 3/4 3 15/16, 4	22220	184.3 6.5	45.4 1.6	840	420	520	260	240	120	60	30	20	16		
110, 115 4 7/16, 4 1/2	22222	209.8 7.4	53.9 1.9	680	340	440	220	200	100	60	30	20	16		
125, 130 4 15/16, 5	22226	300.5 10.6	76.5 2.7	560	280	360	180	160	80						
140, 150 5 7/16, 5 1/2 5 15/16, 6	23230	589.7 20.8	147.4 5.2	480	240	320	160	120	68						
170, 180 6 7/16, 6 1/2 6 15/16, 7	23234	850.0 30.0	241.0 8.5	400	160	240	160	110	60						

HOW TO CONVERT A SOLID-BLOCK HOUSED UNIT FROM FIXED TO EXPANSION (FLOATING)

Flange Cartridge and Flange Block

- Make a reference mark on the housing and retaining nut.
- Loosen the Nylon-tipped set screw that locks the retaining nut in place.
- Loosen the retaining nut by tapping it with a hammer and punch, rotating the retaining nut counterclockwise one complete revolution.
- Tighten the Nylon-tipped set screw.

NOTE

When converting a solid-block housed unit bearing from fixed to expansion, it is imperative that the unit that is going to be converted is correctly oriented. Since the insert in a steel housed unit flange bearing is held against either a shoulder or snap ring opposite the housing retaining nut, a flange bearing that has been converted to expansion can only float in the direction of the retaining nut. Based on this, the retaining nut must be on the side of the housing opposite the fixed bearing.

Pillow Block

- Decide the amount and direction of expansion that's needed. If unidirectional expansion is required, follow the directions outlined above for flange bearings on the nut that is on the side you want the expansion.
- If multi-directional expansion is required, follow the directions outlined above for both nuts on flange housed units.

HOW TO CONVERT A SOLID-BLOCK HOUSED UNIT FROM EXPANSION (FLOATING) TO FIXED

Flange Cartridge and Flange Block

- Loosen the Nylon-tipped set screw that locks the retaining nut in place.
- Tighten the retaining nut by tapping it with a hammer and punch, rotating the retaining nut clockwise until it's tight. It is not possible to overtighten the retaining nut.
- Tighten the Nylon-tipped set screw.

Pillow Block

- Follow the directions above for flange bearings on both nuts on either side of the housing.

NOTE

When converting a solid-block housed unit from expansion to fixed on a mounted bearing, the locking collar set screws must be released to allow the insert to move both in the housing and on the shaft.

TA/DV TAA/DAA SERIES

INSTALLATION PROCEDURE

Depending on the locking style selection and the size of the bearing choose one of the three methods for installing your housed unit. The single nut tapered adapter and the double nut tapered adapter for shaft sizes 5 in. and below (bearing 22228 and smaller) can be installed by either using the axial drive-up method or the tang count method. When using double nut tapered adapters for shaft sizes 135 mm and larger (bearing 22232 and larger) use the TAA/DAA (large sizes) double nut tapered adapter installation procedure.

AXIAL DRIVE-UP METHOD

- Clean all components of any debris and apply a thin oil film to all mating surfaces to ensure proper seating.
- If using an open-end cover, slide the open-end cover/seal combination into position on the shaft.
- For double nut tapered adapters, back off the withdrawal nut by turning it counterclockwise until it only has one or two threads of engagement holding it onto the adapter.
- Slide the adapter sleeve into position on the shaft, then put the housed unit into place on the adapter sleeve.
- Loosely install the housed unit mounting bolts. Check the housed unit alignment. Verify mounting surfaces are in the same flat plane to help achieve good alignment. If shimming is required to minimize misalignment, use full shims across the entire housing base where possible (fig. 41). Washers should be properly sized to the bolt diameter and should not be an SAE grade, which is smaller.
- Put the lockwasher on and thread the locknut onto the adapter sleeve leaving approximately 6.350 mm (¼ in.) between the lockwasher and the inner ring of the bearing.
- Use a large screwdriver or pry bar to lever the sleeve into position until there is no relative movement between the shaft, the adapter sleeve, and the bearing's inner ring.
- Rotate the locknut until hand-tight.
- Tighten the locknut while using a dial indicator to measure the axial movement of the tapered adapter sleeve relative to the bearing's inner ring (see table 53).
- Bend a tang on the lockwasher into a slot on the locknut to prevent the locknut from loosening.
- For double nut tapered adapters, tighten the withdrawal nut by turning it clockwise until it contacts the inner ring of the bearing, tightening the withdrawal nut until snug. Bend a tang on the withdrawal nut lock washer into a slot on the withdrawal nut to prevent the withdrawal nut from loosening.
- Tighten the housed unit mounting bolts.

If using covers:

- Make sure the mating surface of the cover and retaining nuts are clean and dry.
 - Urethane cover: Slightly roughen the mating surface of the cover, place a 3 mm – 6 mm (1/8 in. – 1/4 in.) bead of polyurethane adhesive sealant on the roughened surface.
 - Steel cover: Place a 3 mm – 6 mm (1/8 in. – 1/4 in.) bead of silicone adhesive sealant on the mating surface of the cover.
- Align the cover mounting holes with the mounting holes on the retaining housing nut (make sure that the grease fitting on the cover is accessible when doing so).
- Apply and tighten the cover mounting hardware.

TABLE 53. AXIAL MOVEMENT OF TAPERED ADAPTER SLEEVE RELATIVE TO INNER RING

Shaft Dia.	Bearing No.	Minimum Axial Movement	Maximum Axial Movement
mm in.		mm in.	mm in.
40 1 7/16, 1 1/2	22209	0.38 0.015	0.46 0.018
45 1 11/16, 1 3/4	22210	0.38 0.015	0.46 0.018
50 1 15/16, 2	22211	0.46 0.018	0.56 0.022
55 –	22212	0.46 0.018	0.56 0.022
60 2 3/16, 2 1/4	22213	0.46 0.018	0.56 0.022
65 2 7/16, 2 1/2	22215	0.64 0.025	0.76 0.030
70 2 11/16, 2 3/4	22216	0.64 0.025	0.76 0.030
75 2 15/16, 3	22217	0.69 0.027	0.97 0.038
80 3 3/16, 3 1/4	22218	0.69 0.027	0.97 0.038
85 –	22219	0.69 0.027	0.97 0.038
90 3 7/16, 3 1/2	22220	0.69 0.027	0.97 0.038
100 3 15/16, 4	22222	0.76 0.030	1.07 0.042
110 4 3/16, 4 1/4	22224	0.76 0.030	1.07 0.042
115 4 7/16, 4 1/2	22226	0.89 0.035	1.27 0.050
125 4 15/16, 5	22228	0.89 0.035	1.27 0.050

TANG COUNTING METHOD

- Clean all components of any debris and apply a thin oil film to all mating surfaces to ensure proper seating.
- If using an open-end cover, slide the open-end cover/seal combination into position on the shaft.
- For double nut tapered adapters, back off the withdrawal nut by turning it counterclockwise until it only has one or two threads of engagement holding it onto the adapter.
- Slide the adapter sleeve into the correct position on the shaft, then put the housed unit into place on the adapter sleeve.
- Loosely install the housed unit mounting bolts. Check the housed unit alignment. Verify mounting surfaces are in the same flat plane to help achieve good alignment. If shimming is required to minimize misalignment, use full shims across the entire housing base where possible (fig. 41). Washers should be properly sized to the bolt diameter and should not be an SAE grade, which is smaller.
- Put the lockwasher on and thread the locknut onto the adapter sleeve leaving approximately 6.350 mm (¼ in.) between the lockwasher and the inner ring of the bearing.
- Use a large screwdriver or pry bar to lever the sleeve into position until there is no relative movement between the shaft, the adapter sleeve and the bearing's inner ring.
- Rotate the locknut until hand-tight.
- Note which tang is in line with one slot on the locknut.
- Tighten the locknut until the slot on the locknut passes the number of tangs shown in table 54.
- Bend a tang on the lockwasher into a slot on the locknut to prevent the locknut from loosening.
- For double nut tapered adapters, tighten the withdrawal nut by turning it clockwise until it contacts the inner ring of the bearing, tightening the withdrawal nut until snug. Bend a tang on the withdrawal nut lock washer into a slot on the withdrawal nut to prevent the withdrawal nut from loosening.
- Tighten the housed unit mounting bolts.

If using covers:

- Make sure the mating surface of the cover and retaining nuts are clean and dry.
 - Urethane cover: Slightly roughen the mating surface of the cover, place a 3 mm – 6 mm (1/8 in. – 1/4 in.) bead of polyurethane adhesive sealant on the roughened surface.
 - Steel cover: Place a 3 mm – 6 mm (½ in. – ¼ in.) bead of silicone adhesive sealant on the mating surface of the cover.
- Align the cover mounting holes with the mounting holes on the retaining housing nut (make sure that the grease fitting on the cover is accessible when doing so).
- Apply and tighten the cover mounting hardware.

TABLE 54. NUMBER OF TANGS TO LOCKING

Shaft Dia.	Bearing No.	Number of Tangs
mm in.		
40 1 7/16, 1 1/2	22209	3-4
45 1 11/16, 1 3/4	22210	3-4
50 1 13/16, 2	22211	4-5
55 —	22212	4-5
60 2 3/16, 2 1/4	22213	4-5
65 2 7/16, 2 1/2	22215	5-6
70 2 11/16, 2 3/4	22216	5-6
75 2 13/16, 3	22217	8-9
80 3 3/16, 3 1/4	22218	8-9
85 —	22219	8-9
90 3 7/16, 3 1/2	22220	8-9
100 3 15/16, 4	22222	10-11
110 4 3/16, 4 1/4	22224	10-11
115 4 7/16, 4 1/2	22226	10-11
125 4 15/16, 5	22228	10-11

TAA/DAA SERIES (LARGE SERIES) INSTALLATION PROCEDURE

These instructions are for large sizes of the TAA/DAA series double nut tapered adapter, to be used for shaft sizes 130 mm and up (bearing sizes 22232 and larger).

- Clean all components of any debris and apply a thin oil film to all mating surfaces to ensure proper seating.
- If using an open-end cover, slide the open-end cover/seal combination into position on the shaft.
- Check that the withdrawal nut settings are appropriate for the application shaft size. The axial measurement of the withdrawal nut of the tapered adapter is preset from the factory assuming the shaft is nominal. If the shaft is smaller than nominal, calculate the amount of rotation to adjust the withdrawal nut from the values in table 55 under the withdrawal nut adjustment column (values listed are based on $\frac{1}{4}$ turn of the withdrawal nut). This is done by rotating the withdrawal nut counter-clockwise when looking at front face of the nut. The lockwasher or lock plate will need to be disengaged before rotating the withdrawal nut.
 - For reference, the values for preset are listed in table 55 under column "Withdrawal Nut Initial Setting." Positive numbers imply the sleeve protrudes past the withdrawal nut, while negative number imply the withdrawal nut overhangs the adapter sleeve.
- Slide the adapter sleeve and withdrawal nut into the correct position on the shaft, then put the housed unit into place on the adapter sleeve.
- Loosely install the housed unit mounting bolts. Check the housed unit alignment. Verify mounting surfaces are in the same flat plane to help achieve good alignment. If shimming is required to minimize misalignment, use full shims across the entire housing base where possible (fig. 41). Washers should be properly sized to the bolt diameter and should not be an SAE grade, which is smaller.
- Rotate front locknut by hand until it makes contact with inner ring. Using a wrench, further tighten the front locknut until the inner ring makes contact with the inner face of the withdrawal nut. A hydraulic nut also may be used to do this; however, the front locknut must first be removed, then the bearing tightened with a hydraulic nut. Following this, the front locknut is replaced on to the tapered adapter.
- For bearing sizes 23132K to 23140K, secure the front locknut by bending a tang on the lockwasher into the closest notch on the locknut. For bearing sizes 23144K and larger, secure the front locknut by fixing the lockplate into the closest notch on the locknut.
- Tighten the housed unit mounting bolts.

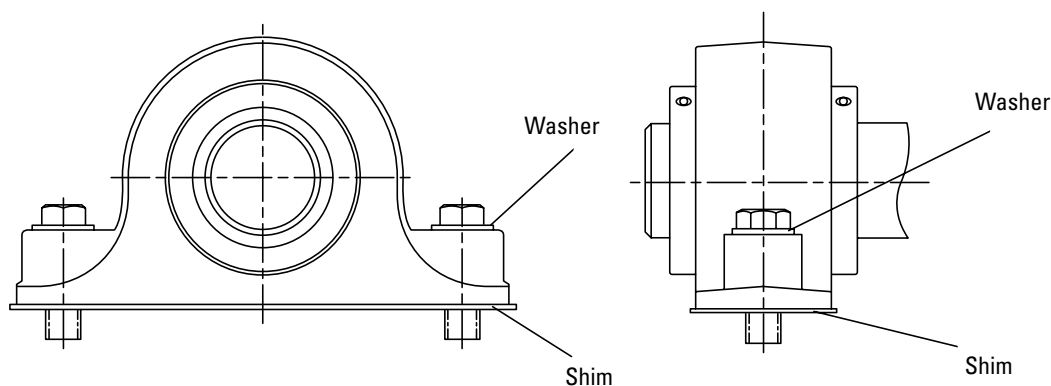

Fig. 41. Use washers and full shims.

CROSS-SECTIONAL VIEW OF BEARINGS

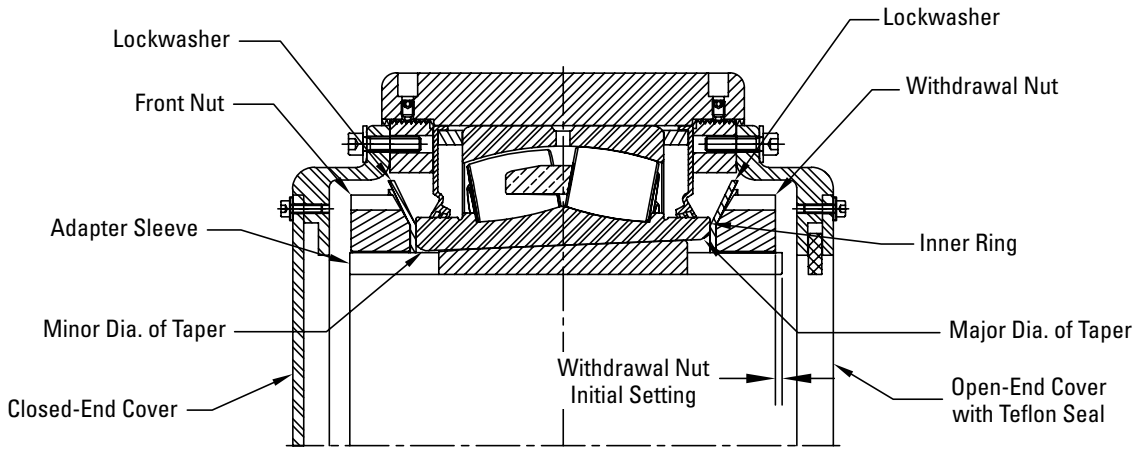

Fig. 42. Cross-sectional view of bearing sizes 23132K to 23140K.

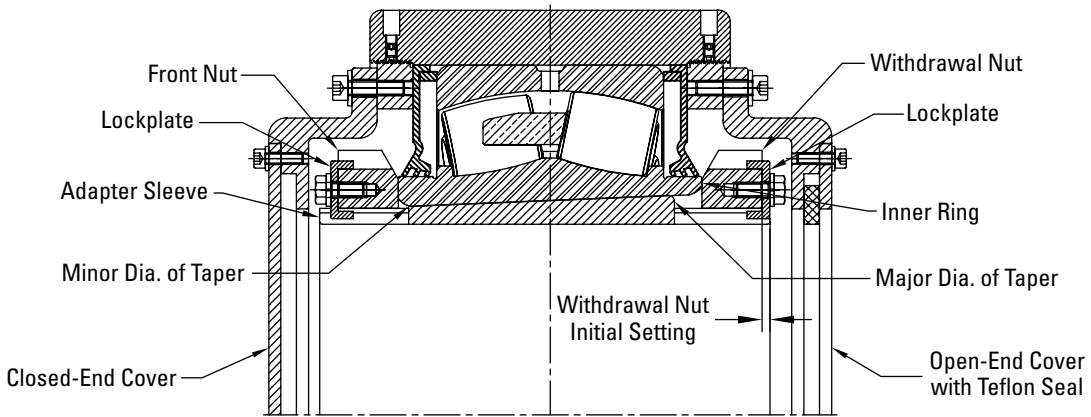

Fig. 43. Cross-sectional view of bearing sizes 23144K and larger.

TABLE 55. INSTALLATION DATA

Shaft Diameter	Bearing Part No.	Max. Speed (0-Seals)	Adapter Thread Spec.	Recommended Shaft Tolerance	Withdrawal Nut Initial Setting	Withdrawal nut adjustment based on a ¼ turn ⁽¹⁾
mm in.		RPM		mm in.	mm in.	mm in.
135, 140 5 ⅜, 5 ⅞, 5 ½	23132K	500	M160 x 3	+0.00 / -0.125 +0.000 / -0.005	5.17 0.203	0.063 0.0025
150 5 ⅜, 5 ⅞, 5 ⅝, 6	23134K	470	M170 x 3	+0.00 / -0.125 +0.000 / -0.005	-1.05 -0.042	0.063 0.0025
160 6 ⅝, 6 ⅞, 6 ⅞, 6 ½	23136K	430	M180 x 3	+0.00 / -0.125 +0.000 / -0.005	-0.31 -0.012	0.063 0.0025
170 6 ⅜, 6 ⅞, 6 ⅝, 7	23138K	400	M190 x 3	+0.00 / -0.125 +0.000 / -0.005	-1.37 -0.054	0.063 0.0025
180 7 ⅞, 7 ⅝, 7 ¼	23140K	400	M200 x 3	+0.00 / -0.125 +0.000 / -0.005	-1.33 -0.052	0.063 0.0025
200 7 ⅜, 7 ⅞, 7 ⅝, 8	23144K	330	Tr220 x 4	+0.00 / -0.125 +0.000 / -0.005	3.07 0.121	0.083 0.0033
220 8 ⅞, 8 ½, 8 ⅝, 9	23148K	310	Tr240 x 4	+0.00 / -0.152 +0.000 / -0.006	2.71 0.107	0.083 0.0033
240 9 ⅞, 9 ½	23152K	250	Tr260 x 4	+0.00 / -0.152 +0.000 / -0.006	2.65 0.104	0.083 0.0033
260 9 ⅝, 10, 10 ⅞, 10 ½	23156K	240	Tr280 x 4	+0.00 / -0.178 +0.000 / -0.007	2.58 0.101	0.083 0.0033
280 10 ⅝, 11	23160K	210	Tr300 x 4	+0.00 / -0.178 +0.000 / -0.007	0.48 0.019	0.083 0.0033
300 11 ⅞, 11 ½, 11 ⅝, 12	23164K	190	Tr320 x 5	+0.00 / -0.178 +0.000 / -0.007	0.30 0.012	0.104 0.0041
320 12 ⅞, 12 ½	23168K	180	Tr340 x 5	+0.00 / -0.203 +0.000 / -0.008	0.34 0.013	0.104 0.0041
340 12 ⅝, 13, 13 ⅞, 13 ½	23172K	170	Tr360 x 5	+0.00 / -0.203 +0.000 / -0.008	0.09 0.003	0.104 0.0041
360 13 ⅝, 14	23176K	160	Tr380 x 5	+0.00 / -0.203 +0.000 / -0.008	0.00 0.00	0.104 0.0041
380 14 ⅝, 15	23180K	150	Tr400 x 5	+0.00 / -0.203 +0.000 / -0.008	0.00 0.00	0.104 0.0041

⁽¹⁾ Calculation would be: Adjustment turns = (0.25 x (nominal shaft size – measured shaft size)) / Withdrawal nut adjustment value from table.

For example, if the shaft is undersized by 0.001 in., you would back off the withdrawal nut by ⅓ of a turn (or 36 degrees), as shown by the following calculation.

If you have a 5 ⅞ in. shaft that is undersized by 0.001 in. (0.25 x (5.4375 in. – 5.4365 in.)) / 0.0025 in.) = 0.1 turns = ⅓ of a turn.

Or in degrees, this would be 360 degrees/10 = 36 degrees.

COVER INSTALLATION

- Make sure the mating surface of the cover and retaining nuts are clean and dry.
- Steel cover: Place a 3-6 mm (1/8 in. – 1/4 in.) bead of silicone adhesive sealant on the mating surface of the cover.
- Align the cover mounting holes with the mounting holes on the retaining housing nut (make sure that the grease fitting on the cover is accessible when doing so).
- Apply and tighten the cover mounting hardware.

TAA/DAA BEARING REMOVAL

- Remove covers, if applicable, by removing cover hardware and disengaging the cover from the housed unit retaining nut.
- Disengage locknut retainer on lockwasher on both front and withdrawal locknuts.
- Remove front locknut.
- Tighten withdrawal nut to disengage bearing from adapter sleeve.
- Slide off bearing, then slide off adapter sleeve.

RELUBRICATION

This information is to aid in the proper lubrication of Timken spherical roller bearing solid-block housed units for the majority of applications.

Housed units have been factory-prelubricated with an NLGI No. 2 lithium-complex, extreme-pressure synthetic grease that combines the benefits of wide operating temperatures and broad compatibility with varied materials. This grease offers excellent thermal stability through temperatures ranging from -40° C to 177° C (-40° F to 350° F). Housed units should be relubricated with this grease or one that is compatible and made for roller bearings. It is vital that the greases used are compatible with the factory installed grease. Please consult with your Timken engineer for the grease specifications if the use of a grease other than the grease mentioned above is needed.

Normal service is considered as operation in a clean, dry environment at temperatures between -34° C to +82° C (-30° F to +180° F). If service is beyond normal conditions due to speed, temperature or exposure to moisture, dirt or corrosive chemicals, periodic relubrication may be necessary. For extreme conditions or conditions in which special chemicals are used, consult with your Timken engineer.

After extended storage or periods when the housed unit is not in operation, fresh grease should be added.

It's important to have the right amount of lubrication because it affects the housed unit bearing operating temperature as well. An inadequate amount of grease could lead to higher operating temperatures due to inadequate lubrication film thickness. Excessive grease will lead to higher operating temperatures due to grease churning, which can cause bearing overheating. It is best to observe the bearing and its temperature and adjust the lubrication as needed. If necessary, use the purge valve or seals that purge to reduce the amount of grease.

Adequate lubrication is an essential element to the housed unit bearing life. Use table 56 as a suggested initial point of reference. Relubrication frequency and quantity intervals are best determined through experience for each application based on types of service, which may differ from the suggestions in the table.

When the housed unit is not in operation for an extended period of time, grease should be added to prevent corrosion.

Table 56 shows general lubrication suggested starting points only. Please read the entire installation instructions prior to using these tables. Applications should be regularly reviewed and lubrication amounts and intervals modified as needed to ensure the best results.

NOTE

Please check with the manufacturer of your grease delivery system for specific information.

TABLE 56. RELUBRICATION INTERVALS

Shaft Dia.	Bearing Part No.	Initial Weight	Relubrication Weight	Relubrication Interval (Hours of Service based on RPM and Temperature deg. F)											
				100 RPM		250 RPM		500 RPM		1000 RPM		2000 RPM		3000 RPM	
				<160°	>160°	<160°	>160°	<160°	>160°	<160°	>160°	<160°	>160°	<160°	>160°
mm in.		g oz.	g oz.												
40 1 1/16, 1 1/2	22209	19.8 0.7	5.7 0.2	2000	1000	1200	600	800	400	320	160	160	80	80	40
45 1 11/16, 1 3/4	22210	22.7 0.8	5.7 0.7	1600	800	1000	500	640	320	240	120	120	60	60	30
50 1 13/16, 2	22211	28.4 1.0	8.5 0.3	1200	600	800	400	440	220	160	80	100	50	60	30
55 —	22212	34.0 1.2	8.5 0.3	1150	580	750	380	400	200	140	70	90	50	50	20
60 2 3/16, 2 1/4	22213	39.7 1.4	11.3 0.4	1120	560	720	360	360	180	120	60	80	40	40	20
65 2 7/16, 2 1/2	22215	76.5 2.7	19.8 0.7	1040	520	680	340	340	170	100	50	60	30		
70 2 11/16, 2 3/4	22216	76.5 2.7	19.8 0.7	1040	520	680	340	340	170	10	50	60	30		
75 2 15/16, 3	22217	96.4 3.4	25.5 0.9	1000	500	640	320	320	160	100	50	60	30		
80 3 3/16, 3 1/4	22218	104.9 3.7	25.5 0.9	960	480	600	300	300	150	80	40	40	20		
85 —	22219	104.9 3.7	25.5 0.9	960	480	600	300	300	150	80	40	40	20		
90 3 7/16, 3 1/2	22220	184.3 6.5	45.4 1.6	840	420	520	260	240	120	60	30				
100 3 15/16, 4	22222	209.8 7.4	53.9 1.9	680	340	440	220	200	100	60	30				
110 4 3/16, 4 1/4	22224	260.8 9.2	68.0 2.4	640	320	400	200	180	90	50	25				
115 4 7/16, 4 1/2	22226	340.2 12.0	85.0 3.0	600	300	360	180	160	80	40	20				
125 4 15/16, 5	22228	396.9 14.0	99.2 3.5	520	260	340	170	140	75						
135, 140 5 3/8, 5 7/16, 5 1/2	23132	593 20.9	116 4.1	480	240	320	160	120	60						
150 5 13/16, 5 7/8, 5 15/16, 6	23134	646 22.8	122 4.3	420	200	280	140	110	60						
160 6 5/16, 6 3/8, 6 7/16, 6 1/2	23136	803 28.3	145 5.1	400	180	240	120								
170 6 13/16, 6 7/8, 6 15/16, 7	23138	956 33.7	167 5.9	380	160	200	110								
180 7 1/8, 7 3/16, 7 1/4	23140	1202 42.4	190 6.7	350	150	150	90								
200 7 13/16, 7 7/8, 7 15/16, 8	23144	1474 52.0	221 7.8	320	140	110	60								
220 8 7/16, 8 1/2, 8 15/16, 9	23148	1942 68.5	255 9.0	290	130	85	45								
240 9 7/16, 9 1/2	23152	2415 85.2	318 11.2	260	120	60	30								
260 9 15/16, 10, 10 7/16, 10 1/2	23156	2745 96.8	335 11.8	230	110										
280 10 15/16, 11	23160	3202 113.0	400 14.1	200	100										
300 11 7/16, 11 1/2, 11 15/16, 12	23164	4112 145.0	476 16.8	170	90										
320 12 7/16, 12 1/2	23168	5093 179.7	550 19.4	140	80										
340 12 15/16, 13, 13 7/16, 13 1/2	23172	5315 187.5	576 20.3	110	60										
360 13 15/16, 14	23176	5725 201.9	601 21.2	85	45										
380 14 15/16, 15	23180	6466 228.1	649 22.9	60	30										

HOW TO CONVERT A SOLID-BLOCK HOUSED UNIT FROM FIXED TO EXPANSION (FLOATING)

Flange Cartridge and Flange Block

- Make a reference mark on the housing and retaining nut.
- Loosen the Teflon-tipped set screw that locks the retaining nut in place.
- Loosen the retaining nut by tapping it with a hammer and punch, rotating the retaining nut counterclockwise one complete revolution.
- Tighten the Teflon-tipped set screw.

NOTE

When converting a solid-block housed unit bearing from fixed to expansion, it is imperative that the unit that is going to be converted is correctly oriented. Since the insert in a steel housed unit flange bearing is held against either a shoulder or snap ring opposite the housing retaining nut, a flange bearing that has been converted to expansion can only float in the direction of the retaining nut. Based on this, the retaining nut must be on the side of the housing opposite the fixed bearing.

Pillow Block

- Decide the amount and direction of expansion that's needed. If unidirectional expansion is required, follow the directions outlined above for flange bearings on the nut that is on the side you want the expansion.
- If multi-directional expansion is required, follow the directions above for both nuts on flange housed units.

HOW TO CONVERT A SOLID-BLOCK HOUSED UNIT FROM EXPANSION (FLOATING) TO FIXED

Flange Cartridge and Flange Block

- Loosen the Teflon-tipped set screw that locks the retaining nut in place.
- Tighten the retaining nut by tapping it with a hammer and punch, rotating the retaining nut clockwise until tight. It is not possible to overtighten the retaining nut.
- Tighten the Teflon-tipped set screw.

Pillow Block

- Follow the directions above for flange bearings on both

nuts on either side of the housing.

NOTE

When converting a solid-block housed unit from expansion to fixed on a mounted bearing, the locking-collar set screws must be released to allow the insert to move both in the housing and on the shaft.



WARNING

Failure to observe the following warnings could create a risk of death or serious injury.

Proper maintenance and handling practices are critical. Always follow installation instructions and maintain proper lubrication.

Overheated bearings can ignite explosive atmospheres. Special care must be taken to properly select, install, maintain, and lubricate housed unit bearings that are used in or near atmospheres that may contain explosive levels of combustible gases or accumulations of dust such as from grain, coal, or other combustible materials. Consult your equipment designer or supplier for installation and maintenance instructions.

If hammer and bar are used for installation or removal of a part, use a mild steel bar (e.g., 1010 or 1020 grade). Mild steel bars are less likely to cause release of high speed fragments from the hammer or bar or the part being installed or removed.



CAUTION

Failure to follow these cautions may result in property damage.

Do not use damaged housed units.

DISCLAIMER

Every reasonable effort has been made to ensure the accuracy of the information in this writing, but no liability is accepted for errors, omissions or for any other reason.



V-LOCK SERIES

The V-Lock locking mechanism (U.S. Pat. No. 7344313) evenly distributes force on the shaft, helping eliminate fretting corrosion. V-Lock provides maximum holding power and prevents overtightening.

The following topics are covered within this section:

Introduction	90
QVVP Two-Bolt Pillow Blocks	92
QVVPL Two-Bolt Pillow Blocks	93
QVVPA SAF Two-Bolt Pillow Blocks	94
QVVPN SN-Style Two-Bolt Pillow Blocks	95
QVVSN SN-Style Two-Bolt Pillow Blocks	96
QVVPKT 9000 Series Two-Bolt Pillow Blocks	97
QVVPF Four-Bolt Pillow Blocks	98
QVVPR Four-Bolt Pillow Blocks	99
QVV PX 5000 Series Four-Bolt Pillow Blocks	100
QVV PXT 5000 Series Two-Bolt Pillow Blocks	101
QVVPG SN-Style Four-Bolt Pillow Blocks	102
QVVPH SAF-Style Four-Bolt Pillow Blocks	103
QVVPK 9000 Series Four-Bolt Pillow Blocks	104
QVF and QVVF Square Flange Blocks	105
QVFB and QVFB Square Flange Blocks	106
QVFC and QVFC Piloted Flange Cartridges	107
QVFL and QVFL Square Flange Blocks	108
QVFX and QVFX 5000 Series Square Flange Blocks	109
QVFK and QVFK 9000 Series Square Flange Blocks	110
QVFNL Series Square Flange Blocks	111
QV FY and QV FY Round Flange Blocks	112
QVC and QVVC Piloted Flange Cartridges	113
QVCW and QVVCW Piloted Flange Cartridges	114
QVMC and QVVMC Cartridge Blocks	115
QVVTU Take-Up Blocks	116

V-LOCK SERIES

The V-Lock series is specifically designed to address common spherical roller bearing solid-block housed unit problems:

- Reliable mechanical withdrawal
- Preset spherical inner ring radial internal clearances (feeler gages are not required)
- Quick installation (typically 10 minutes or less)
- Highest shaft-holding power
- Works well in high-speed applications where shaft centering is an issue



Fig. 44. V-Lock series insert.

YOU HAVE CHOICES

For the V-Lock series, you can select either single-nut or double-nut versions and choose from many seal configurations and housing styles, which are shown on page 15.

HOUSINGS

- Two-bolt pillow blocks
- Four-bolt pillow blocks
- Flange blocks
- Piloted flange cartridges
- Cartridge blocks
- Take-up blocks

SEALS

- Labyrinth: DuPont™ Teflon® (T)
- Triple-lip: nitrile rubber (M), urethane (O) and Viton® (N)
- Double-lip: nitrile rubber (B) and Viton (C)
- Steel and urethane closed-end covers (CS)
- Steel and urethane open-end covers (CV) with:
 - DuPont Teflon (T)
 - Triple-lip seal (DR)
 - V-ring seal (VR)

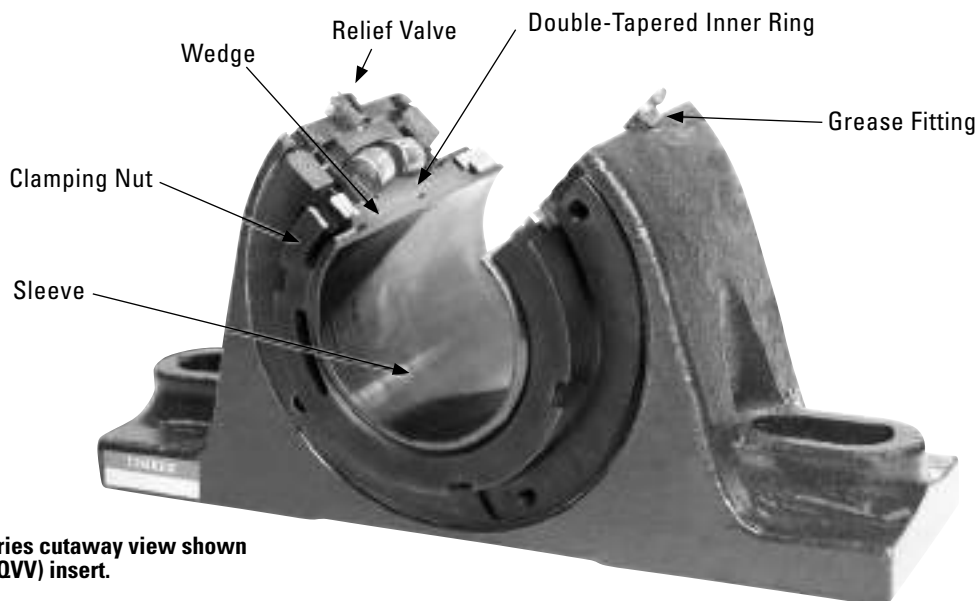

Fig. 45. V-Lock series cutaway view shown with double-nut (QVV) insert.

V-LOCK SERIES WRENCH

New V-Lock series wrenches make installation easy; the wrenches are specifically designed for the V-Lock adapter sleeves, providing three or four points of contact and maximum wrench engagement versus traditional spanner wrench designs. Made from tough high alloy steel for long service life. Eight wrenches are all you need for the 36 different bore sizes.

Fig. 46. V-Lock series wrench.

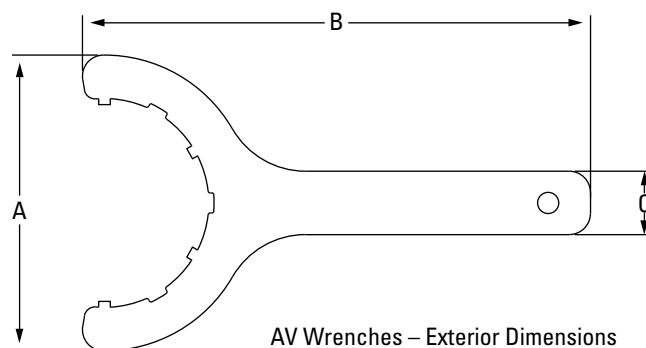
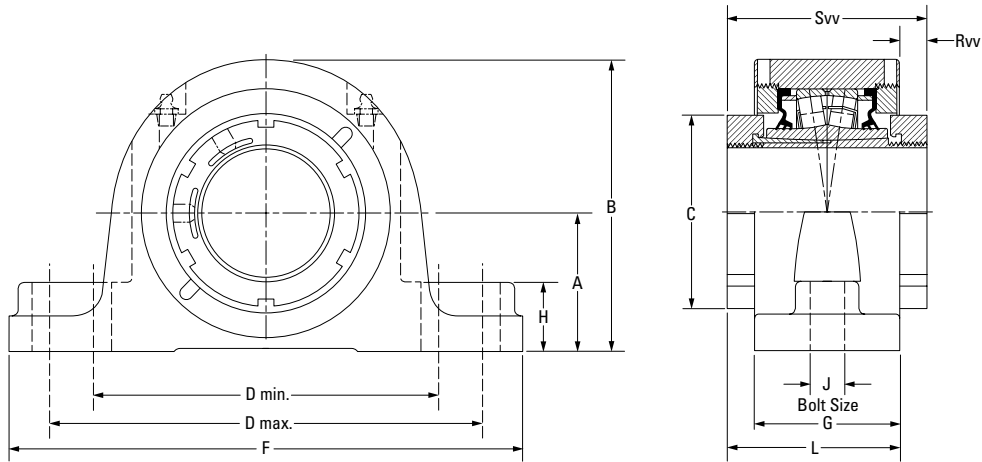

TABLE 57. V-LOCK SERIES WRENCH DIMENSIONS

Part #	Shaft Dia.	A	B	C
	mm in.	in.	in.	in.
AVWR11	1 15/16 in. 2 in. 50 mm	5.03	10.78	1.50
AVWR12-13	2 3/16 in. 2 1/4 in. 55 mm	5.19	10.89	1.50
AVWR14-15	60 mm 2 7/16 in. 2 1/2 in. 65 mm	5.74	11.25	1.50
AVWR16-17	2 11/16 in. 2 3/4 in. 70 mm 2 15/16 in. 3 in. 75 mm	6.30	11.61	1.50
AVWR19-20	3 3/16 in. 3 1/4 in. 80 mm 85 mm 3 7/16 in. 3 1/2 in. 90 mm	7.00	12.02	1.50
AVWR22	3 11/16 in. 3 3/4 in. 100 mm 3 15/16 in. 4 in.	7.54	12.67	1.50
AVWR26	110 mm 4 7/16 in. 4 1/2 in. 115 mm	8.92	13.30	1.50
AVWR28	125 mm 4 15/16 in. 5 in. 130 mm	9.52	13.65	1.50

QVVP TWO-BOLT PILLOW BLOCKS – STRAIGHT BORE EQUIVALENT



Bearing Part No. ⁽¹⁾	Shaft Dia.	Bearing No.	A	B	C	D min.	D max.	F	G	H	J	L	Rvv	Svv	Wt.	
	mm in.		mm in.	mm in.	mm in.	mm in.	mm in.	mm in.	mm in.	mm in.	mm in.	mm in.	mm in.	mm in.	kg lbs.	
QVVP11V115S	1 1/8 in.	22211	57.2	122.2	75.9	152.4	181.1	225.6	62.0	31.8	16	82.0	20.1	102.1	6.4	
QVVP11V200S	2 in.		2.25	4.81	2.99	6.00	7.13	8.88	2.44	1.25	5/8	3.23	0.79	4.02	14	
QVVP11V050S	50 mm															
QVVP12V203S	2 3/8 in.	22212	63.5	133.4	80.3	165.1	200.2	244.6	66.8	31.8	16	84.6	17.8	102.1	7.7	
QVVP12V204S	2 1/4 in.		2.50	5.25	3.16	6.50	7.88	9.63	2.63	1.25	5/8	3.33	0.70	4.02	17	
QVVP12V055S	55 mm															
QVVP14V060S	60 mm	22214	69.9	147.3	94.0	174.8	219.2	260.4	73.7	35.1	16	88.9	15.2	103.9	10.0	
QVVP14V207S	2 7/8 in.		2.75	5.80	3.70	6.88	8.63	10.25	2.90	1.38	5/8	3.50	0.60	4.09	22	
QVVP14V208S	2 1/2 in.															
QVVP14V065S	65 mm															
QVVP16V211S	2 1/8 in.	22216	79.5	164.3	106.4	200.2	244.6	295.4	76.2	35.1	20	91.2	15.0	106.2	12.7	
QVVP16V212S	2 3/4 in.		3.13	6.47	4.19	7.88	9.63	11.63	3.00	1.38	3/4	3.59	0.59	4.18	28	
QVVP16V070S	70 mm															
QVVP16V215S	2 1/8 in.															
QVVP16V300S	3 in.															
QVVP16V075S	75 mm															
QVVP19V303S	3 3/8 in.	22219	95.3	195.3	124.5	238.3	285.8	342.9	86.6	47.8	24	102.1	15.5	117.6	20.4	
QVVP19V304S	3 1/4 in.		3.75	7.69	4.90	9.38	11.25	13.50	3.41	1.88	7/8	4.02	0.61	4.63	45	
QVVP19V080S	80 mm															
QVVP19V085S	85 mm															
QVVP19V307S	3 7/8 in.															
QVVP19V308S	3 1/2 in.															
QVVP19V090S	90 mm															
QVVP22V311S	3 1/8 in.	22222	104.9	219.7	139.7	255.0	320.0	362.0	102.6	50.8	24	116.6	14.0	130.3	26.8	
QVVP22V312S	3 3/4 in.		4.13	8.65	5.50	10.04	12.60	14.25	4.04	2.00	1	4.59	0.55	5.13	59	
QVVP22V100S	100 mm															
QVVP22V315S	3 1/8 in.															
QVVP22V400S	4 in.															

⁽¹⁾Double-nut (QVV) part number shown. Single-nut (QV) version available upon request.

QVVPL TWO-BOLT PILLOW BLOCKS – STRAIGHT BORE EQUIVALENT

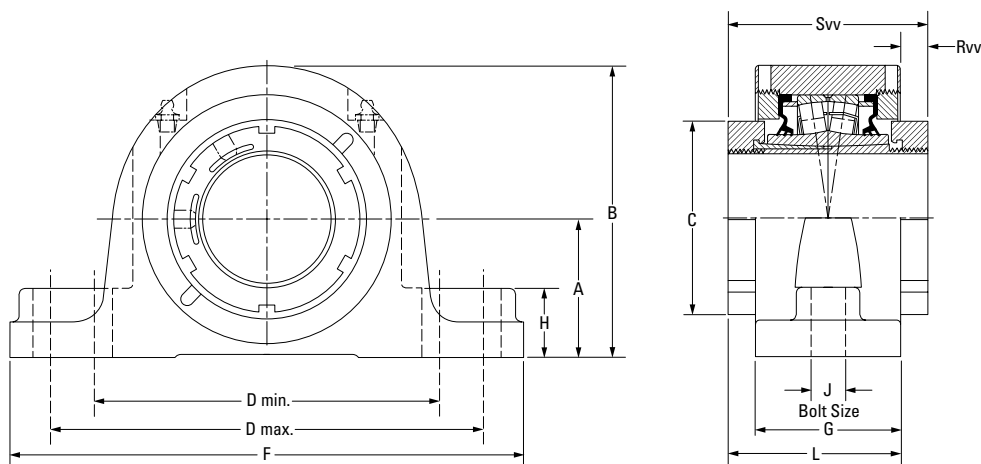

Bearing Part No. ⁽¹⁾	Shaft Dia.	Bearing No.	A	B	C	D min.	D max.	F	G	H	J	L	Rvv	Svv	Wt.
	mm in.		mm in.	mm in.	mm in.	mm in.	mm in.	mm in.	mm in.	mm in.	mm in.	mm in.	mm in.	mm in.	kg lbs.
QVVPL11V115S	1 1/16 in.	22211	57.2	122.2	75.9	150.6	161.5	212.9	62.0	31.8	16	82.0	20.1	102.1	6.4
QVVPL11V200S	2 in.		2.25	4.81	2.99	5.93	6.36	8.38	2.44	1.25	5/8	3.23	0.79	4.02	14
QVVPL11V050S	50 mm														
QVVPL12V203S	2 3/16 in.	22212	63.5	133.4	80.3	165.1	179.3	225.6	65.5	31.8	16	83.8	18.3	102.1	7.7
QVVPL12V204S	2 1/4 in.		2.50	5.25	3.16	6.50	7.06	8.88	2.58	1.25	5/8	3.30	0.72	4.02	17
QVVPL12V055S	55 mm														
QVVPL14V060S	60 mm	22214	69.9	147.3	94.0	173	189.0	235.0	73.7	35.1	16	88.9	15.2	103.9	10.0
QVVPL14V207S	2 7/16 in.		2.75	5.80	3.70	6.81	7.44	9.25	2.90	1.38	5/8	3.50	0.60	4.09	22
QVVPL14V208S	2 1/2 in.														
QVVPL14V065S	65 mm	22216	82.6	167.4	106.4	195.6	213.4	265.2	76.2	35.1	20	91.2	15.0	106.2	12.7
QVVPL16V211S	2 1/16 in.		3.25	6.59	4.19	7.70	8.40	10.44	3.00	1.38	3/4	3.59	0.59	4.18	28
QVVPL16V212S	2 3/8 in.														
QVVPL16V070S	70 mm	22219	95.3	195.3	124.5	235.0	273.1	330.2	86.6	47.8	24	102.1	15.5	117.6	20.4
QVVPL16V215S	2 15/16 in.		3.75	7.69	4.90	9.25	10.75	13.00	3.41	1.88	7/8	4.02	0.61	4.63	45
QVVPL16V300S	3 in.														
QVVPL16V075S	75 mm	22222	108	223	139.7	255.0	320.0	362.0	102.6	53.8	24	116.6	14.0	130.3	26.8
QVVPL19V303S	3 3/16 in.		4.25	8.78	5.50	10.04	12.60	14.25	4.04	2.12	1	4.59	0.55	5.13	59
QVVPL19V304S	3 1/4 in.														
QVVPL19V080S	80 mm	22219	95.3	195.3	124.5	235.0	273.1	330.2	86.6	47.8	24	102.1	15.5	117.6	20.4
QVVPL19V085S	85 mm		3.75	7.69	4.90	9.25	10.75	13.00	3.41	1.88	7/8	4.02	0.61	4.63	45
QVVPL19V307S	3 7/16 in.														
QVVPL19V308S	3 1/2 in.	22219	95.3	195.3	124.5	235.0	273.1	330.2	86.6	47.8	24	102.1	15.5	117.6	20.4
QVVPL19V090S	90 mm		3.75	7.69	4.90	9.25	10.75	13.00	3.41	1.88	7/8	4.02	0.61	4.63	45
QVVPL22V311S	3 1/16 in.														
QVVPL22V312S	3 3/8 in.	22222	108	223	139.7	255.0	320.0	362.0	102.6	53.8	24	116.6	14.0	130.3	26.8
QVVPL22V100S	100 mm		4.25	8.78	5.50	10.04	12.60	14.25	4.04	2.12	1	4.59	0.55	5.13	59
QVVPL22V315S	3 15/16 in.														
QVVPL22V400S	4 in.														

⁽¹⁾Double-nut (QVV) part number shown. Single-nut (QV) version available upon request.

QVPA SAF TWO-BOLT PILLOW BLOCKS – TAPERED BORE EQUIVALENT

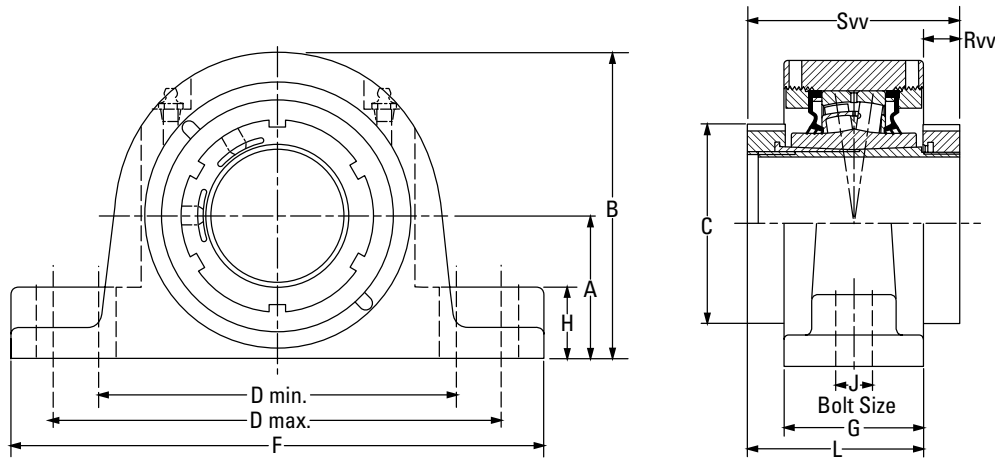

Bearing Part No. ⁽¹⁾	Shaft Dia.	Bearing No.	A	B	C	D min.	D max.	F	G	H	J	L	Rvv	Svv	Wt.
	mm in.		mm in.	mm in.	mm in.	mm in.	mm in.	mm in.	mm in.	mm in.	mm in.	mm in.	mm in.	mm in.	kg lbs.
QVPA13V203S	2 3/16 in.	22213	76.2	151.1	80.3	182.9	241.3	269.5	68.6	31.2	16	85.3	16.8	102.1	10.4
QVPA13V204S	2 1/4 in.		3.00	5.95	3.16	7.20	9.50	10.61	2.70	1.23	5/8	3.36	0.66	4.02	23
QVPA13V055S	55 mm														
QVPA15V060S	60 mm	22215	82.6	163.3	94.0	200.2	244.6	276.4	68.6	31.8	16	86.4	17.8	103.9	12.2
QVPA15V207S	2 7/16 in.		3.25	6.43	3.70	7.88	9.63	10.88	2.70	1.25	5/8	3.40	0.70	4.09	27
QVPA15V208S	2 1/2 in.														
QVPA15V065S	65 mm	22216	88.9	176.7	106.4	228.6	279.4	330.2	72.6	31.8	20	88.2	15.5	103.7	12.2
QVPA16V211S	2 11/16 in.		3.50	6.96	4.19	9.00	11.00	13.00	2.86	1.25	3/4	3.47	0.61	4.08	27
QVPA16V212S	2 3/4 in.														
QVPA16V070S	70 mm	22217	95.3	186	106.4	241.3	279.4	320.8	76.2	33.8	20	91.2	15.0	106.2	15.0
QVPA17V211S	2 11/16 in.		3.75	7.32	4.19	9.50	11.00	12.63	3.00	1.33	3/4	3.59	0.59	4.18	33
QVPA17V212S	2 3/4 in.														
QVPA17V300S	3 in.	22219	101.6	203.1	124.5	254.0	298.5	349.3	79.8	41.3	20	97.0	17.2	114.1	22.2
QVPA17V075S	75 mm		4.00	8.00	4.90	10.00	11.75	13.75	3.14	1.63	3/4	3.82	0.68	4.49	49
QVPA19V303S	3 3/16 in.														
QVPA19V304S	3 1/4 in.	22220	114.3	219.2	124.5	276.4	333.5	374.7	86.9	41.4	24	102.4	15.5	117.6	29.5
QVPA19V080S	80 mm		4.50	8.63	4.90	10.88	13.13	14.75	3.42	1.63	7/8	4.03	0.61	4.63	65
QVPA20V303S	3 3/16 in.														
QVPA20V304S	3 1/4 in.	22222	125.5	240.5	139.7	317.5	368.3	406.4	100.6	50.8	24	115.6	15.0	130.3	38.1
QVPA20V080S	80 mm		4.94	9.47	5.50	12.50	14.50	16.00	3.96	2.00	7/8	4.55	0.59	5.13	84
QVPA20V085S	85 mm														
QVPA20V307S	3 7/16 in.	22226	152.4	284.0	174.8	362.0	400.1	444.5	128.0	51.8	24	143.2	35.2	178.3	61.7
QVPA20V308S	3 1/2 in.		6.00	11.18	6.88	14.25	15.75	17.50	5.04	2.04	1	5.64	1.39	7.02	136
QVPA20V090S	90 mm														
QVPA22V311S	3 11/16 in.	22228	152.4	297.2	190.0	384.3	441.5	499.9	108.0	51.8	30	132.0	46.5	178.3	61.8
QVPA22V312S	3 3/4 in.		6.00	11.70	7.48	15.13	17.38	19.68	4.25	2.04	1 1/4	5.20	1.83	7.02	136
QVPA22V100S	100 mm														
QVPA22V315S	3 15/16 in.	22226	152.4	297.2	190.0	384.3	441.5	499.9	108.0	51.8	30	132.0	46.5	178.3	61.8
QVPA22V400S	4 in.		6.00	11.70	7.48	15.13	17.38	19.68	4.25	2.04	1 1/4	5.20	1.83	7.02	136
QVPA26V110S	110 mm														
QVPA26V407S	4 7/16 in.	22226	152.4	284.0	174.8	362.0	400.1	444.5	128.0	51.8	24	143.2	35.2	178.3	61.7
QVPA26V408S	4 1/2 in.		6.00	11.18	6.88	14.25	15.75	17.50	5.04	2.04	1	5.64	1.39	7.02	136
QVPA26V115S	115 mm														
QVPA28V125S	125 mm	22228	152.4	297.2	190.0	384.3	441.5	499.9	108.0	51.8	30	132.0	46.5	178.3	61.8
QVPA28V415S	4 15/16 in.		6.00	11.70	7.48	15.13	17.38	19.68	4.25	2.04	1 1/4	5.20	1.83	7.02	136
QVPA28V500S	5 in.														
QVPA28V130S	130 mm														

⁽¹⁾Double-nut (QVV) part number shown. Single-nut (QV) version available upon request.

QVVPN SN-STYLE TWO-BOLT PILLOW BLOCKS – TAPERED BORE EQUIVALENT

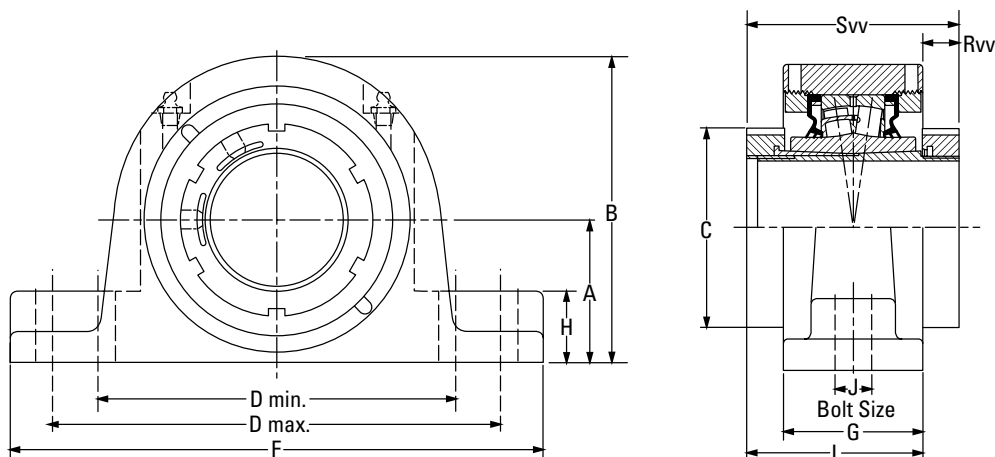

Bearing Part No. ⁽¹⁾	Shaft Dia.	Bearing No.	A	B	C	D min.	D max.	F	G	H	J	L	Rvv	Svv	Wt.	
	mm in.		mm in.	mm in.	mm in.	mm in.	mm in.	mm in.	mm in.	mm in.	mm in.	mm in.	mm in.	mm in.	kg lbs.	
QVVPN11V115S	1 1/16 in.	22211	69.9	135.4	75.9	165.1	221.0	251.0	60.5	31.8	16	81.3	20.8	102.1	7.7	
QVVPN11V200S	2 in.		2.75	5.33	2.99	6.50	8.70	9.88	2.38	1.25	5/8	3.20	0.82	4.02	17	
QVVPN11V050S	50 mm															
QVVPN12V055S	55 mm	22212	70.0	140.5	80.0	177.8	219.2	254.0	60.5	31.8	16	81.3	20.8	102.1	9.1	
			2.76	5.53	3.15	7.00	8.63	10.00	2.38	1.25	5/8	3.20	0.82	4.02	20	
QVVPN13V203S	2 3/16 in.	22213	80.0	154.9	80.3	182.9	241.3	269.5	68.6	35.1	16	85.3	16.8	102.1	10.4	
QVVPN13V204S	2 1/4 in.		3.15	6.10	3.16	7.20	9.50	10.61	2.70	1.38	5/8	3.36	0.66	4.02	23	
QVVPN14V060S	60 mm	22214	80.0	157.5	94.0	195.6	235.0	275.0	74.0	35.1	16	89.0	15.0	104.0	10.4	
			3.15	6.20	3.70	7.70	9.25	10.83	2.91	1.38	5/8	3.50	0.59	4.09	23	
QVVPN15V207S	2 7/16 in.	22215	80.0	160.8	94.0	200.2	244.6	276.4	68.6	29.2	16	86.4	17.8	103.9	12.2	
QVVPN15V208S	2 1/2 in.		3.15	6.33	3.70	7.88	9.63	10.88	2.70	1.15	5/8	3.40	0.70	4.09	27	
QVVPN15V065S	65 mm															
QVVPN16V211S	2 1/16 in.	22216	95.0	180.3	106.4	235.0	266.7	315.0	72.6	31.8	20	89.4	16.8	106.0	13.6	
QVVPN16V212S	2 3/4 in.		3.74	7.10	4.19	9.25	10.50	12.40	2.86	1.25	3/4	3.52	0.66	4.17	30	
QVVPN16V070S	70 mm															
QVVPN17V215S	2 1/16 in.		22217	95.3	185.9	106.4	241.3	279.4	320.8	76.2	33.8	20	91.2	15.0	106.2	15.0
QVVPN17V300S	3 in.			3.75	7.32	4.19	9.50	11.00	12.63	3.00	1.33	3/4	3.59	0.59	4.18	33
QVVPN17V075S	75 mm															
QVVPN19V303S	3 3/16 in.	22219	100.0	195.3	124.5	285.8	295.4	344.9	86.6	38.9	20	102.0	16.0	118.1	22.2	
QVVPN19V304S	3 1/4 in.		3.94	7.69	4.90	11.25	11.63	13.58	3.41	1.53	3/4	4.02	0.63	4.65	49	
QVVPN19V080S	80 mm															
QVVPN19V085S	85 mm	22219	112.0	212.3	124.5	285.8	295.4	346.2	82.8	38.9	20	100.6	17.8	118.1	23.1	
			4.41	8.36	4.90	11.25	11.63	13.63	3.26	1.53	3/4	3.96	0.70	4.65	51	
QVVPN20V307S	3 3/16 in.	22220	112.0	216.9	124.5	276.4	333.5	374.7	86.9	38.9	24	102.4	15.5	117.6	29.5	
QVVPN20V308S	3 1/2 in.		4.41	8.54	4.90	10.88	13.13	14.75	3.42	1.53	7/8	4.03	0.61	4.63	65	
QVVPN20V090S	90 mm															
QVVPN22V311S	3 1/16 in.	22222	125.5	240.5	139.7	317.5	368.3	406.4	100.6	50.8	24	115.6	15.0	130.3	38.1	
QVVPN22V312S	3 3/4 in.		4.94	9.47	5.50	12.50	14.50	16.00	3.96	2.00	7/8	4.55	0.59	5.13	84	
QVVPN22V100S	100 mm															
QVVPN22V315S	3 1/16 in.		22228	150.0	394.9	190.0	384.3	441.5	423.9	108.0	49.5	30	132.0	46.5	178.3	63.0
QVVPN22V400S	4 in.			5.91	11.61	7.48	15.13	17.38	16.69	4.25	1.95	1 1/4	5.20	1.83	7.02	138
QVVPN24V110S	110 mm	22224	140.0	262.9	174.8	344.4	355.6	409.7	97.8	50.8	24	138.2	40.4	178.3	49.9	
			5.51	10.35	6.88	13.56	14.00	16.13	3.85	2.00	7/8	5.44	1.59	7.02	110	
QVVPN26V407S	4 7/16 in.	22226	150.0	281.7	174.8	362.0	400.1	444.5	128.0	49.3	24	153.2	25.1	178.3	61.7	
QVVPN26V408S	4 1/2 in.		5.91	11.09	6.88	14.25	15.75	17.50	5.04	1.94	1	6.03	0.99	7.02	136	
QVVPN26V115S	115 mm															
QVVPN28V125S	125 mm	22228	150.0	394.9	190.0	384.3	441.5	423.9	108.0	49.5	30	132.0	46.5	178.3	63.0	
QVVPN28V415S	4 1/16 in.		5.91	11.61	7.48	15.13	17.38	16.69	4.25	1.95	1 1/4	5.20	1.83	7.02	138	
QVVPN28V500S	5 in.															
QVVPN28V130S	130 mm															

⁽¹⁾Double-nut (QVV) part number shown. Single-nut (QV) version available upon request.

QVVSN SN-STYLE TWO-BOLT PILLOW BLOCKS – PURE METRIC DESIGN

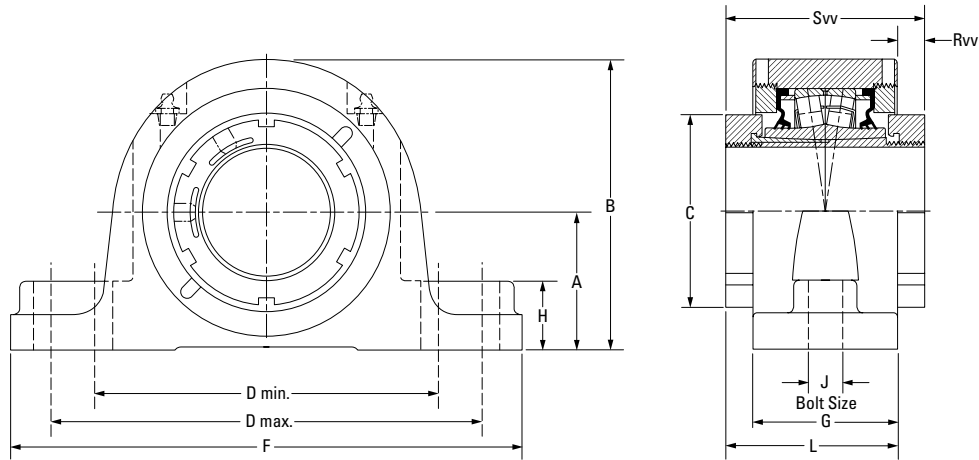

Bearing Part No. ⁽¹⁾	Shaft Dia.	Bearing No.	A	B	C	D min.	D max.	F	G	H	J	L	Rvv	Svv	Wt.
	mm in.		mm in.	mm in.	mm in.	mm in.	mm in.	mm in.	mm in.	mm in.	mm in.	mm in.	mm in.	mm in.	kg lbs.
QVVSN11V115S	1 15/16 in.	22211	70	136	76	183	216	254	68	25	16	85	17	102	8.4
QVVSN11V200S	2 in.		2.76	5.35	2.99	7.20	8.50	10.00	2.68	0.98	5/8	3.35	0.67	4.02	18
QVVSN11V050S	50 mm														
QVVSN12V203S	2 3/16 in.	22212	70	141	80	183	216	254	68	25	16	85	17	102	13.2
QVVSN12V204S	2 1/4 in.		2.76	5.54	3.16	7.20	8.50	10.00	2.69	0.98	5/8	3.35	0.67	4.02	29
QVVSN12V055S	55 mm														
QVVSN14V060S	60 mm	22214	80	157	94	196	235	275	74	35	16	89	15	104	16.8
QVVSN14V207S	2 7/16 in.		3.15	6.20	3.70	7.70	9.25	10.83	2.91	1.38	5/8	3.50	0.59	4.09	37
QVVSN14V208S	2 1/2 in.														
QVVSN14V065S	65 mm														
QVVSN16V211S	2 11/16 in.	22216	95	183	106	241	279	316	76	34	20	91	15	106	20.9
QVVSN16V212S	2 3/4 in.		3.74	7.19	4.19	9.50	11	12.44	3.00	1.32	3/4	3.58	0.59	4.17	46
QVVSN16V070S	70 mm														
QVVSN16V215S	2 15/16 in.														
QVVSN16V300S	3 in.														
QVVSN16V075S	75 mm														
QVVSN19V303S	3 3/16 in.	22219	100	200	124	280	292	345	86	39	20	102	16	118	25.4
QVVSN19V304S	3 1/4 in.		3.94	7.87	4.90	11.02	11.50	13.58	3.38	1.53	3/4	4.02	0.63	4.65	56
QVVSN19V080S	80 mm														
QVVSN19V085S	85 mm														
QVVSN19V307S	3 7/16 in.	22219	112	212	124	290	327	380	86	39	24	102	16	118	25.4
QVVSN19V308S	3 1/2 in.		4.41	8.34	4.90	11.42	12.87	14.96	3.38	1.53	7/8	4.02	0.63	4.65	56
QVVSN19V090S	90 mm														
QVVSN22V311S	3 11/16 in.	22222	125	241	140	320	366	410	101	50	24	116	15	130	35.8
QVVSN22V312S	3 3/4 in.		4.92	9.48	5.50	12.58	14.42	16.14	3.96	1.98	7/8	4.57	0.59	5.12	79
QVVSN22V100S	100 mm														
QVVSN22V315S	3 15/16 in.														
QVVSN22V400S	4 in.														
QVVSN26V110S	110 mm	22226	140	270	175	332	365	410	113	39	24	146	33	178	39.9
QVVSN26V407S	4 7/16 in.		5.51	10.63	6.88	13.08	14.37	16.14	4.43	1.55	7/8	5.75	1.30	7.01	88
QVVSN26V408S	4 1/2 in.	22226	150	279	175	367	400	445	113	49	24	146	33	178	39.9
QVVSN26V115S	115 mm		5.91	10.99	6.88	14.45	15.75	17.52	4.43	1.94	7/8	5.75	1.30	7.01	88
QVVSN28V125S	125 mm														
QVVSN28V415S	4 15/16 in.	22228	150	294	190	402	435	500	116	49	30	148	31	178	67.0
QVVSN28V500S	5 in.		5.91	11.56	7.48	15.84	17.13	19.68	4.56	1.94	1 1/4	5.83	1.22	7.01	147
QVVSN28V130S	130 mm														

⁽¹⁾Double-nut (QVV) part number shown. Single-nut (QV) version available upon request.

QVVPKT 9000 SERIES TWO-BOLT PILLOW BLOCKS – TAPERED BORE EQUIVALENT

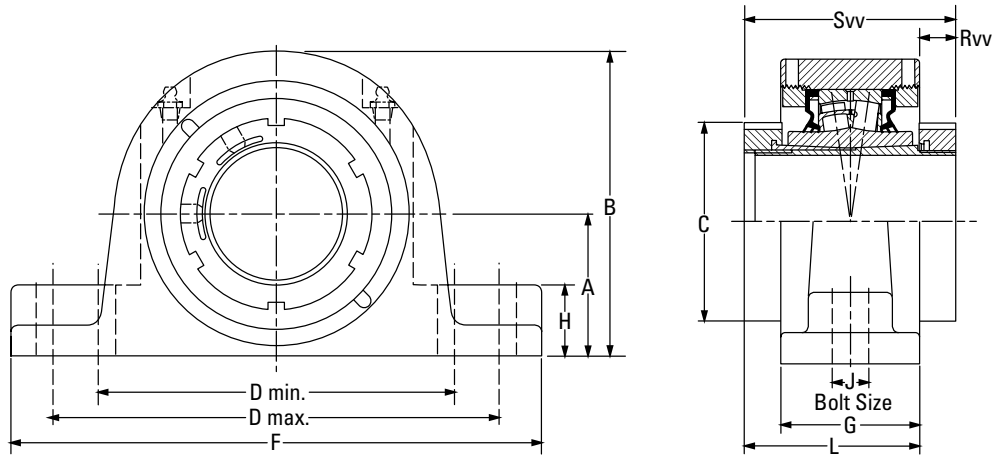

Bearing Part No. ⁽¹⁾	Shaft Dia.	Bearing No.	A	B	C	D min.	D max.	F	G	H	J	L	Rvv	Svv	Wt.	
	mm in.		mm in.	mm in.	mm in.	mm in.	mm in.	mm in.	mm in.	mm in.	mm in.	mm in.	mm in.	mm in.	kg lbs.	
QVVPKT13V203S	2 3/16 in.	22213	76.2	153.7	80.3	194.6	223.0	285.8	73.7	35.1	20	87.9	14.2	102.1	10.0	
QVVPKT13V204S	2 1/4 in.		3.00	6.05	3.16	7.66	8.78	11.25	2.90	1.38	3/4	3.46	0.56	4.02	22	
QVVPKT13V055S	55 mm															
QVVPKT15V060S	60 mm	22215	88.9	173.7	94.0	230.1	265.2	330.2	75.7	35.1	24	89.9	14.2	103.9	12.7	
QVVPKT15V207S	2 7/16 in.		3.50	6.84	3.70	9.06	10.44	13.00	2.98	1.38	7/8	3.54	0.56	4.09	28	
QVVPKT15V208S	2 1/2 in.															
QVVPKT15V065S	65 mm															

⁽¹⁾Double-nut (QVV) part number shown. Single-nut (QV) version available upon request.

QVVPF FOUR-BOLT PILLOW BLOCKS – STRAIGHT BORE EQUIVALENT

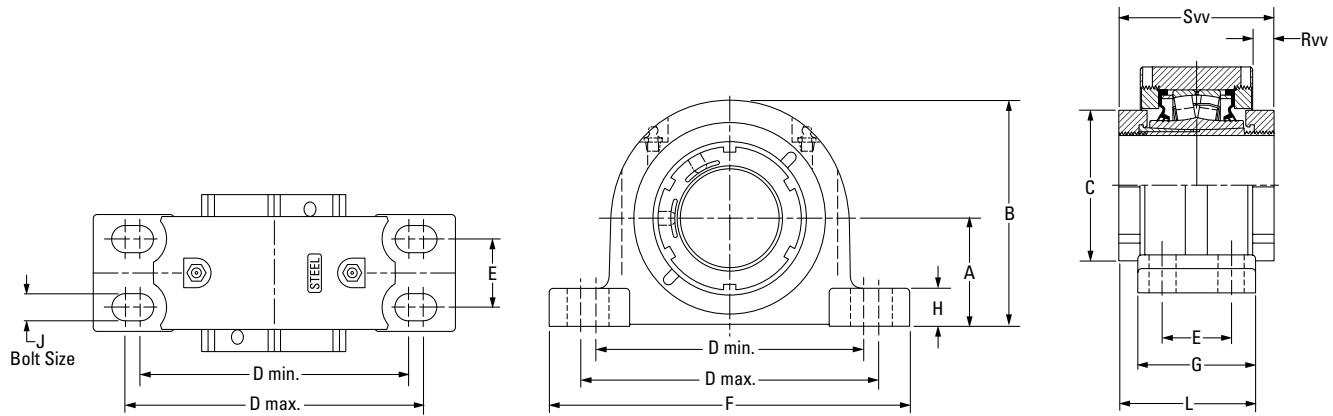

Bearing Part No. ⁽¹⁾	Shaft Dia.	Bearing No.	A	B	C	D min.	D max.	E	F	G	H	J	L	Rvv	Svv	Wt.
	mm in.		mm in.	mm in.	mm in.	mm in.	mm in.	mm in.	mm in.	mm in.	mm in.	mm in.	mm in.	mm in.	mm in.	kg lbs.
QVVPF14V060S	60 mm	22214	69.9 2.75	147.3 5.80	94.0 3.70	174.8 6.88	193.8 7.63	44.5 1.75	235.0 9.25	76.2 3.00	24.9 0.98	16 %	90.2 3.55	15.2 0.60	103.9 4.09	9.1 20
QVVPF14V207S	2 7/8 in.															
QVVPF14V208S	2 1/2 in.															
QVVPF14V065S	65 mm	22216	82.6 3.25	167.4 6.59	106.4 4.19	193.0 7.60	231.1 9.10	47.8 1.88	265.2 10.44	79.5 3.13	32.8 1.29	16 %	93.0 3.66	15.2 0.60	106.2 4.18	12.2 27
QVVPF16V211S	2 1/8 in.															
QVVPF16V212S	2 3/4 in.															
QVVPF16V070S	70 mm	22219	95.3 3.75	195.3 7.69	124.5 4.90	225.6 8.88	276.4 10.88	50.8 2.00	312.4 12.30	95.3 3.75	39.6 1.56	20 3/4	106.4 4.19	14.5 0.57	117.6 4.63	22.2 49
QVVPF16V215S	2 15/16 in.															
QVVPF16V300S	3 in.															
QVVPF16V075S	75 mm	22222	108.0 4.25	223.0 8.78	139.7 5.50	276.4 10.88	339.9 13.38	57.2 2.25	378.0 14.88	109.5 4.31	35.6 1.40	20 3/4	119.9 4.72	14.7 0.58	130.3 5.13	30.4 67
QVVPF19V303S	3 3/8 in.															
QVVPF19V304S	3 1/4 in.															
QVVPF19V080S	80 mm	22226	120.7 4.75	250.7 9.87	174.8 6.88	301.8 11.88	368.3 14.50	63.5 2.50	409.7 16.13	120.7 4.75	40.1 1.58	20 3/4	149.6 5.89	32.8 1.29	178.3 7.02	37.2 82
QVVPF19V085S	85 mm															
QVVPF19V307S	3 7/8 in.															
QVVPF19V308S	3 1/2 in.	22228	139.7 5.50	279.7 11.01	190.0 7.48	349.3 13.75	403.4 15.88	69.9 2.75	444.5 17.50	128.0 5.04	39.1 1.54	24 7/8	153.2 6.03	31.5 1.24	178.3 7.02	60.8 134
QVVPF19V090S	90 mm															
QVVPF22V311S	3 1/8 in.															
QVVPF22V312S	3 3/4 in.															
QVVPF22V100S	100 mm															
QVVPF22V315S	3 15/16 in.															
QVVPF22V400S	4 in.															
QVVPF26V110S	110 mm															
QVVPF26V407S	4 7/8 in.															
QVVPF26V408S	4 1/2 in.															
QVVPF26V115S	115 mm															
QVVPF28V125S	125 mm															
QVVPF28V415S	4 15/16 in.															
QVVPF28V500S	5 in.															
QVVPF28V130S	130 mm															

⁽¹⁾Double-nut (QVV) part number shown. Single-nut (QV) version available upon request.

QVVPR FOUR-BOLT PILLOW BLOCKS – STRAIGHT BORE EQUIVALENT

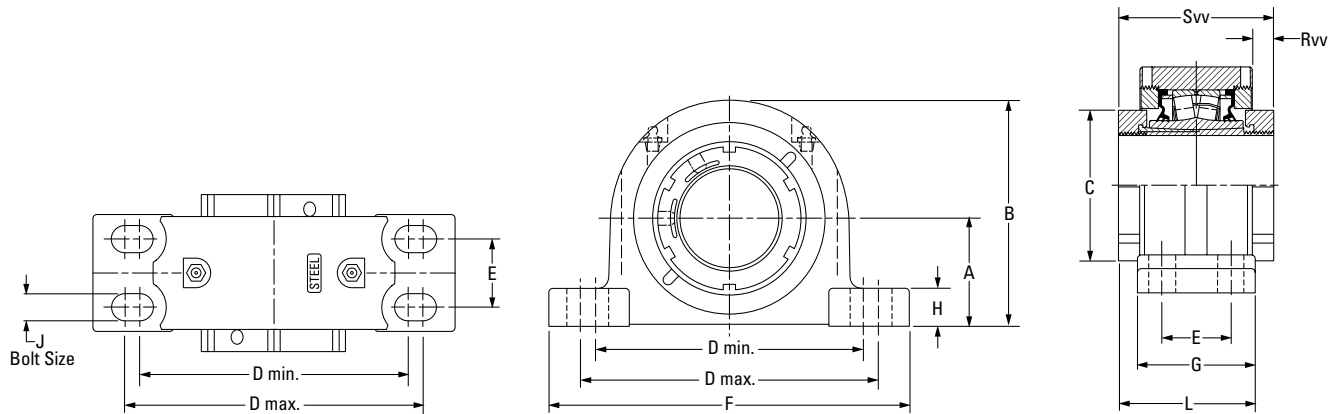

Bearing Part No. ⁽¹⁾	Shaft Dia.	Bearing No.	A	B	C	D min.	D max.	E	F	G	H	J	L	Rvv	Svv	Wt.
	mm in.		mm in.	mm in.	mm in.	mm in.	mm in.	mm in.	mm in.	mm in.	mm in.	mm in.	mm in.	mm in.	mm in.	kg lbs.
QVVPR14V060S	60 mm	22214	69.9 2.75	147.3 5.80	94.0 3.70	181.1 7.13	222.2 8.75	47.8 1.88	260.4 10.25	82.6 3.25	24.9 0.98	16 5/8	93.2 3.67	15.2 0.60	103.9 4.09	9.1 20
QVVPR14V207S	2 7/16 in.															
QVVPR14V208S	2 1/2 in.															
QVVPR14V065S	65 mm															
QVVPR16V211S	2 1/16 in.	22216	79.5 3.13	164.3 6.47	106.4 4.19	203.2 8.00	243.8 9.60	54.1 2.13	275.1 10.83	85.9 3.38	29.5 1.16	16 5/8	96.0 3.78	15.2 0.60	106.2 4.18	12.2 27
QVVPR16V212S	2 3/4 in.															
QVVPR16V070S	70 mm															
QVVPR16V215S	2 15/16 in.															
QVVPR16V300S	3 in.	22219	95.3 3.75	195.3 7.69	124.5 4.90	235.0 9.25	285.8 11.25	60.5 2.38	346.2 13.63	95.3 3.75	39.6 1.56	20 3/4	106.4 4.19	14.5 0.57	117.6 4.63	22.2 49
QVVPR16V075S	75 mm															
QVVPR19V303S	3 3/16 in.															
QVVPR19V304S	3 1/4 in.															
QVVPR19V080S	80 mm															
QVVPR19V085S	85 mm															
QVVPR19V307S	3 7/16 in.															
QVVPR19V308S	3 1/2 in.															
QVVPR19V090S	90 mm															

⁽¹⁾Double-nut (QVV) part number shown. Single-nut (QV) version available upon request.

QVVPX 5000 SERIES FOUR-BOLT PILLOW BLOCKS – STRAIGHT BORE EQUIVALENT

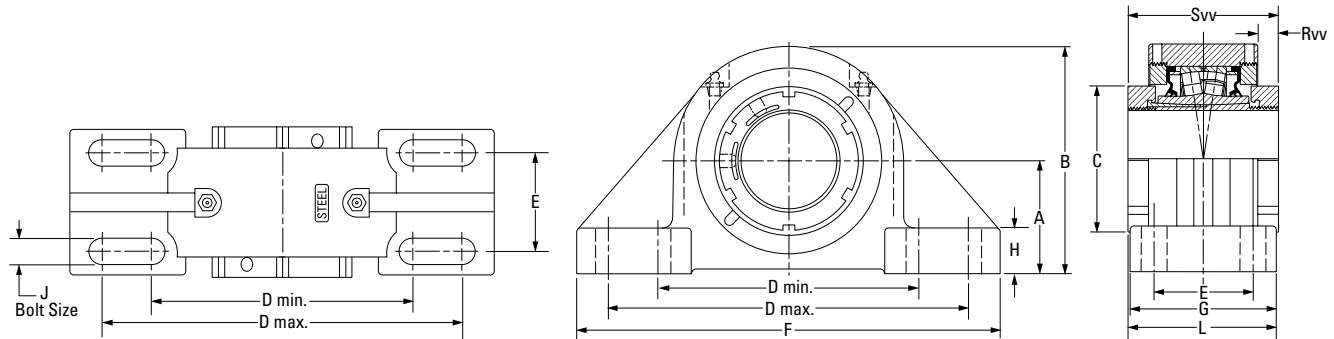

Bearing Part No. ⁽¹⁾	Shaft Dia.	Bearing No.	A	B	C	D min.	D max.	E	F	G	H	J	L	Rv	Sv	Wt.
	mm in.		mm in.	mm in.	mm in.	mm in.	mm in.	mm in.	mm in.	mm in.	mm in.	mm in.	mm in.	mm in.	mm in.	kg lbs.
QVVPX14V060S	60 mm	22214	76.2 3.00	153.7 6.05	94.0 3.70	176.3 6.94	242.8 9.56	66.8 2.63	285.8 11.25	98.6 3.88	31.0 1.23	16 5/8	101.3 3.99	15.2 0.60	103.9 4.09	10.4 23
QVVPX14V207S	2 7/16 in.															
QVVPX14V208S	2 1/2 in.															
QVVPX14V065S	65 mm	22216	88.9 3.50	173.5 6.83	106.4 4.19	230.1 9.06	265.2 10.44	69.9 2.75	330.2 13.00	108.0 4.25	39.1 1.54	20 3/4	107.2 4.22	14.2 0.56	106.2 4.18	12.7 28
QVVPX16V211S	2 11/16 in.															
QVVPX16V212S	2 3/4 in.															
QVVPX16V070S	70 mm	22219	101.6 4.00	201.2 7.92	124.5 4.90	274.6 10.81	309.6 12.19	76.2 3.00	381.0 15.00	120.7 4.75	38.1 1.50	20 3/4	119.1 4.69	14.5 0.57	117. 4.63	22.2 49
QVVPX16V215S	2 15/16 in.															
QVVPX16V300S	3 in.															
QVVPX16V075S	75 mm	22222	127.0 5.00	239.8 9.44	139.7 5.50	317.5 12.50	355.6 14.00	88.9 3.50	425.5 16.75	139.7 5.50	41.4 1.63	24 7/8	135.1 5.32	15.2 0.60	130.3 5.13	30.4 67
QVVPX19V303S	3 3/16 in.															
QVVPX19V304S	3 1/4 in.															
QVVPX19V080S	80 mm	22226	146.1 5.75	273.8 10.78	174.8 6.88	354.1 13.94	395.2 15.56	101.6 4.00	469.9 18.50	158.8 6.25	45.7 1.80	24 1	168.7 6.64	38.4 1.51	178.3 7.02	37.2 82
QVVPX19V085S	85 mm															
QVVPX19V307S	3 7/16 in.															
QVVPX19V308S	3 1/2 in.	22228	155.6 6.125	293.4 11.55	190.0 7.48	387.4 15.25	425.5 16.75	108.0 4.25	514.4 20.25	171.5 6.75	50.8 2.00	24 1 1/8	175.0 6.89	30.7 1.21	178.3 7.02	61.7 136
QVVPX19V090S	90 mm															
QVVPX22V311S	3 11/16 in.															
QVVPX22V312S	3 3/4 in.															
QVVPX22V315S	3 15/16 in.															
QVVPX22V400S	4 in.															
QVVPX22V100S	100 mm															
QVVPX26V110S	110 mm															
QVVPX26V407S	4 7/16 in.															
QVVPX26V408S	4 1/2 in.															
QVVPX26V115S	115 mm															
QVVPX28V125S	125 mm															

⁽¹⁾Double-nut (QVV) part number shown. Single-nut (QV) version available upon request.

QVVPXT 5000 SERIES TWO-BOLT PILLOW BLOCKS – STRAIGHT BORE EQUIVALENT

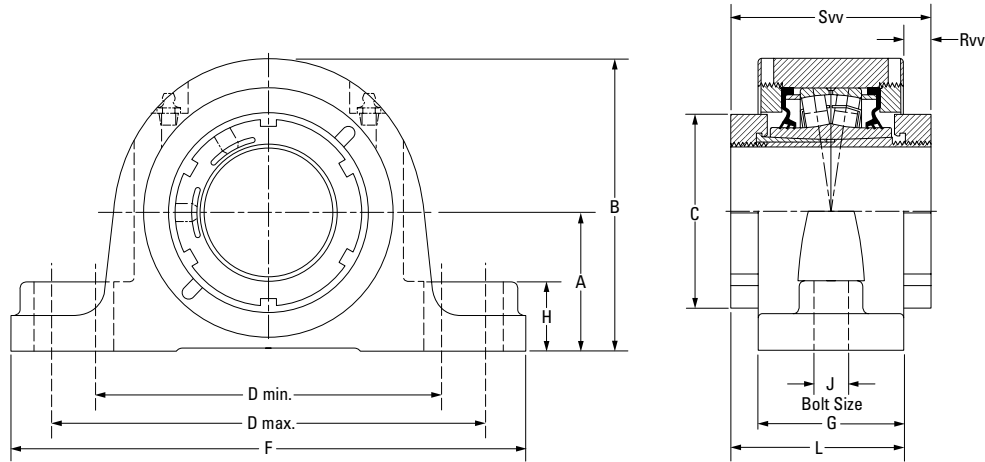

Bearing Part No. ⁽¹⁾	Shaft Dia.	Bearing No.	A	B	C	D min.	D max.	F	G	H	J	L	Rvv	Svv	Wt.
	mm in.		mm in.	mm in.	mm in.	mm in.	mm in.	mm in.	mm in.	mm in.	mm in.	mm in.	mm in.	mm in.	kg lbs.
QVVPXT14V060S	60 mm	22214	76.2 3.00	153.7 6.05	94.0 3.70	194.6 7.66	233.0 8.78	285.8 11.25	73.7 2.90	35.1 1.38	20 ¾	88.9 3.50	15.2 0.60	103.9 4.09	10.0 22
QVVPXT14V207S	2 ¾ in.														
QVVPXT14V208S	2 ½ in.														
QVVPXT14V065S	65 mm														
QVVPXT16V211S	2 1/16 in.	22216	88.9 3.50	173.7 6.84	106.4 4.19	230.1 9.06	265.2 10.44	330.2 13.00	75.7 2.98	35.1 1.38	24 7/8	90.9 3.58	15.2 0.60	106.2 4.18	12.7 28
QVVPXT16V212S	2 ¾ in.														
QVVPXT16V070S	70 mm														
QVVPXT16V215S	2 1/16 in.														
QVVPXT16V300S	3 in.														
QVVPXT16V075S	75 mm														

⁽¹⁾Double-nut (QVV) part number shown. Single-nut (QV) version available upon request.

QVVPG SN-STYLE FOUR-BOLT PILLOW BLOCKS – TAPERED BORE EQUIVALENT

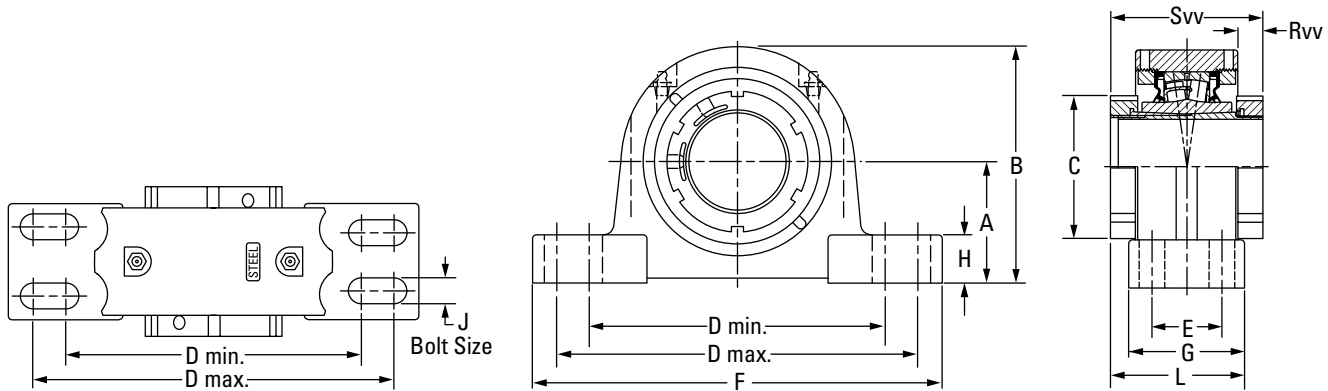

Bearing Part No. ⁽¹⁾	Shaft Dia.	Bearing No.	A	B	C	D min.	D max.	E	F	G	H	J	L	Rvv	Svv	Wt.
	mm in.		mm in.	mm in.	mm in.	mm in.	mm in.	mm in.	mm in.	mm in.	mm in.	mm in.	mm in.	mm in.	mm in.	kg lbs.
QVVPG11V115S	1 15/16 in.	22211	69.9	134.9	75.9	182.4	217.4	39.9	251.0	68.6	31.8	16	85.3	20.8	102.1	8.6
QVVPG11V200S	2 in.		2.75	5.31	2.99	7.18	8.56	1.57	9.88	2.70	1.25	5/8	3.36	0.82	4.02	19
QVVPG11V050S	50 mm															
QVVPG12V055S	55 mm	22212	70.0	140.5	80.0	177.8	219.2	35.1	254.0	69.9	31.8	12	86.1	20.8	102.1	9.9
QVVPG13V203S	2 3/8 in.	22213	80.0	154.9	80.3	182.4	217.4	48.0	261.9	82.6	35.1	16	92.5	17.0	102.1	11.3
QVVPG13V204S	2 1/4 in.		3.15	6.10	3.16	7.18	8.56	1.89	10.31	3.25	1.38	5/8	3.64	0.67	4.02	25
QVVPG14V060S	60 mm	22214	80.0	154.9	94.0	182.4	217.4	48.0	261.9	82.6	35.1	16	93.2	13.7	103.9	11.3
QVVPG15V207S	2 7/8 in.	22215	80.0	162.1	94.0	201.7	246.1	39.6	276.4	79.5	30.2	16	91.7	15.7	103.9	13.2
QVVPG15V208S	2 1/2 in.		3.15	6.38	3.70	7.94	9.69	1.56	10.88	3.13	1.19	5/8	3.61	0.62	4.09	29
QVVPG15V065S	65 mm															
QVVPG16V211S	2 13/16 in.	22216	95.0	180.3	105.9	235.0	266.7	50.0	315.0	89.9	31.8	16	98.0	16.8	105.9	14.9
QVVPG16V212S	2 3/4 in.		3.74	7.10	4.17	9.25	10.50	1.97	12.4	3.54	1.25	5/8	3.86	0.66	4.17	33
QVVPG16V070S	70 mm															
QVVPG17V215S	2 15/16 in.	22217	95.0	182.9	106.4	240.0	287.3	52.3	320.8	92.2	31.8	20	99.3	15.0	106.2	16.8
QVVPG17V300S	3 in.		3.74	7.20	4.19	9.44	11.31	2.06	12.63	3.63	1.25	3/4	3.91	0.59	4.18	37
QVVPG17V075S	75 mm															
QVVPG19V303S	3 3/8 in.	22219	100.0	195.3	124.0	282.7	298.5	50.0	344.9	100.1	39.6	16	109.2	19.3	118.1	24.5
QVVPG19V304S	3 1/4 in.		3.937	7.69	4.88	11.13	11.75	1.97	13.58	3.94	1.56	5/8	4.30	0.76	4.65	54
QVVPG19V080S	80 mm															
QVVPG19V085S	85 mm	22219	112.0	212.3	124.0	282.7	298.5	50.0	344.9	100.1	39.6	16	109.2	17.8	118.1	25.4
QVVPG20V307S	3 7/8 in.	22220	112.0	214.6	124.5	276.4	339.9	60.5	381.0	109.5	39.6	20	113.5	11.2	117.6	31.8
QVVPG20V308S	3 1/2 in.		4.409	8.45	4.90	10.88	13.38	2.38	15.00	4.31	1.56	3/4	4.47	0.44	4.63	70
QVVPG20V090S	90 mm															
QVVPG22V311S	3 11/16 in.	22222														
QVVPG22V312S	3 3/4 in.		125.0	238.3	139.7	301.8	368.3	69.9	409.7	120.7	44.5	20	125.5	14.5	130.3	39.5
QVVPG22V100S	100 mm		4.921	9.38	5.50	11.88	14.50	2.75	16.13	4.75	1.75	3/4	4.94	0.57	5.13	87
QVVPG22V315S	3 15/16 in.															
QVVPG22V400S	4 in.															
QVVPG24V110S	110 mm	22224	140.0	262.9	174.8	330.2	355.6	70.1	410.0	120.7	50.8	16	149.6	40.4	178.3	49.9
QVVPG26V407S	4 7/8 in.	22226	150.0	281.7	174.8	367.3	400.1	81.0	444.5	128.0	49.3	24	153.2	36.6	178.3	61.7
QVVPG26V408S	4 1/2 in.		5.906	11.09	6.88	14.46	15.75	3.19	17.50	5.04	1.94	1	6.03	1.44	7.02	136
QVVPG26V115S	115 mm															
QVVPG28V125S	125 mm	22228														
QVVPG28V415S	4 15/16 in.		150.0	288.5	190.0	384.3	447.8	80.0	500.4	128.0	49.3	24	152.9	31.8	178.3	61.7
QVVPG28V500S	5 in.		5.906	11.36	7.48	15.13	17.63	3.15	19.70	5.04	1.94	1	6.02	1.25	7.02	136
QVVPG28V130S	130 mm															

⁽¹⁾Double-nut (QVV) part number shown. Single-nut (QV) version available upon request.

QVVPH SAF-STYLE FOUR-BOLT PILLOW BLOCKS – TAPERED BORE EQUIVALENT

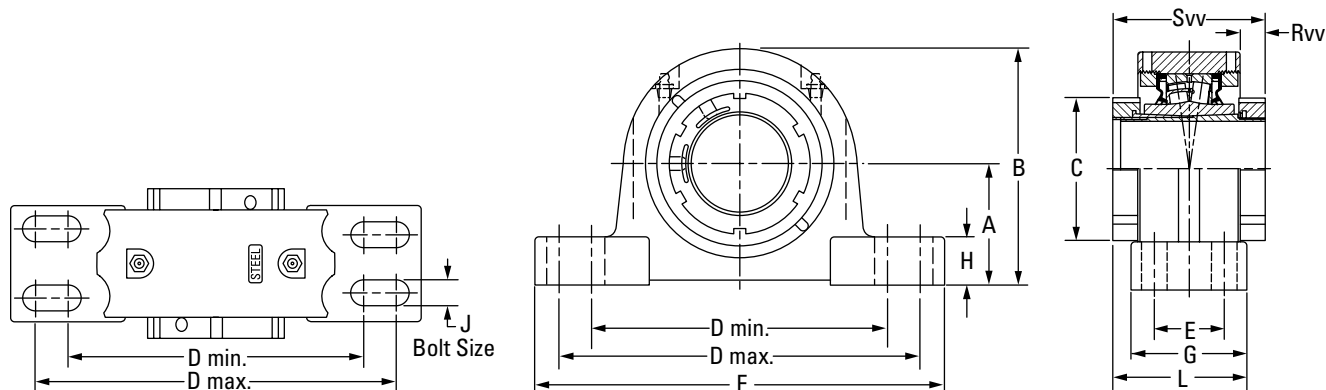

Bearing Part No. ⁽¹⁾	Shaft Dia.	Bearing No.	A	B	C	D min.	D max.	E	F	G	H	J	L	Rvv	Svv	Wt.
	mm in.		mm in.	mm in.	mm in.	mm in.	mm in.	mm in.	mm in.	mm in.	mm in.	mm in.	mm in.	mm in.	mm in.	kg lbs.
QVVPH11V115S	1 1/16 in.	22211	69.9	134.9	75.9	182.4	217.4	39.9	251.0	68.6	31.8	16	85.3	20.8	102.1	8.6
QVVPH11V200S	2 in.		2.75	5.31	2.99	7.18	8.56	1.57	9.88	2.70	1.25	5/8	3.36	0.82	4.02	19
QVVPH11V050S	50 mm															
QVVPH13V203S	2 3/16 in.	22213	76.2	151.1	80.3	182.4	217.4	50.8	261.9	82.6	31.2	12	92.5	17.0	102.1	11.3
QVVPH13V204S	2 1/4 in.		3.00	5.95	3.16	7.18	8.56	2.00	10.31	3.25	1.23	1/2	3.64	0.67	4.02	25
QVVPH13V055S	55 mm															
QVVPH15V060S	60 mm	22215	82.6	162.1	94.0	201.7	246.1	47.8	276.4	79.5	32.8	12	91.7	18.0	103.9	13.2
QVVPH15V207S	2 7/16 in.		3.25	6.38	3.70	7.94	9.69	1.88	10.88	3.13	1.29	1/2	3.61	0.71	4.09	29
QVVPH15V208S	2 1/2 in.															
QVVPH15V065S	65 mm	22216	88.9	176.7	109.2	228.6	279.4	54.0	300.2	72.6	31.8	16	96.3	15.5	103.9	14.9
QVVPH16V211S	2 1/16 in.		3.50	6.96	4.30	9.00	11.00	2.13	13.00	2.86	1.25	5/8	3.79	0.61	4.09	33
QVVPH16V212S	2 3/4 in.															
QVVPH16V070S	70 mm	22217	95.3	182.9	106.4	240.0	287.3	54.1	320.8	92.2	32.0	16	99.3	15.0	106.2	16.8
QVVPH17V215S	2 1/16 in.		3.75	7.20	4.19	9.44	11.31	2.13	12.63	3.63	1.26	5/8	3.91	0.59	4.18	37
QVVPH17V300S	3 in.															
QVVPH17V075S	75 mm	22219	101.6	202.2	124.5	254.0	298.5	54.0	349.3	98.4	41.3	16	106.3	17.2	114.1	24.5
QVVPH19V303S	3 3/16 in.		4.00	7.96	4.90	10.00	11.75	2.13	13.75	3.88	1.63	5/8	4.18	0.68	4.49	54
QVVPH19V304S	3 1/4 in.															
QVVPH19V080S	80 mm	22220	114.3	216.9	124.5	276.4	339.9	60.5	381.0	109.5	41.9	20	113.5	11.2	117.6	31.8
QVVPH20V303S	3 3/16 in.		4.50	8.54	4.90	10.88	13.38	2.38	15.00	4.31	1.65	3/4	4.47	0.44	4.63	70
QVVPH20V304S	3 1/4 in.															
QVVPH20V080S	80 mm	22222	125.5	238.3	139.7	301.8	368.3	69.9	406.4	120.7	45.0	20	125.5	14.5	130.3	39.5
QVVPH20V085S	85 mm		4.94	9.38	5.50	11.88	14.50	2.75	16.00	4.75	1.77	3/4	4.94	0.57	5.13	87
QVVPH20V307S	3 7/16 in.															
QVVPH20V308S	3 1/2 in.	22224	133.4	256.8	174.6	301.8	368.3	69.9	419.1	120.7	50.8	20	149.5	40.3	178.3	49.9
QVVPH20V090S	90 mm		5.25	10.11	6.87	11.88	14.50	2.75	16.50	4.75	2.00	3/4	5.89	1.59	7.02	110
QVVPH22V311S	3 1/16 in.															
QVVPH22V312S	3 3/8 in.	22226	152.4	284.0	174.8	362.0	400.1	82.6	444.5	128.0	51.8	22	153.2	36.6	178.3	61.7
QVVPH22V100S	100 mm		6.00	11.18	6.88	14.25	15.75	3.25	17.50	5.04	2.04	7/8	6.03	1.44	7.02	136
QVVPH22V315S	3 1/16 in.															
QVVPH22V400S	4 in.	22228	152.4	290.8	190.0	406.4	435.1	85.9	500.4	128.0	51.8	24	152.9	31.8	178.3	61.7
QVVPH28V125S	125 mm		6.00	11.45	7.48	16.00	17.13	3.38	19.70	5.04	2.04	1	6.02	1.25	7.02	136
QVVPH28V415S	4 1/16 in.															
QVVPH28V500S	5 in.															
QVVPH28V130S	130 mm															

⁽¹⁾Double-nut (QVV) part number shown. Single-nut (QV) version available upon request.

QVVPK 9000 SERIES FOUR-BOLT PILLOW BLOCKS – TAPERED BORE EQUIVALENT

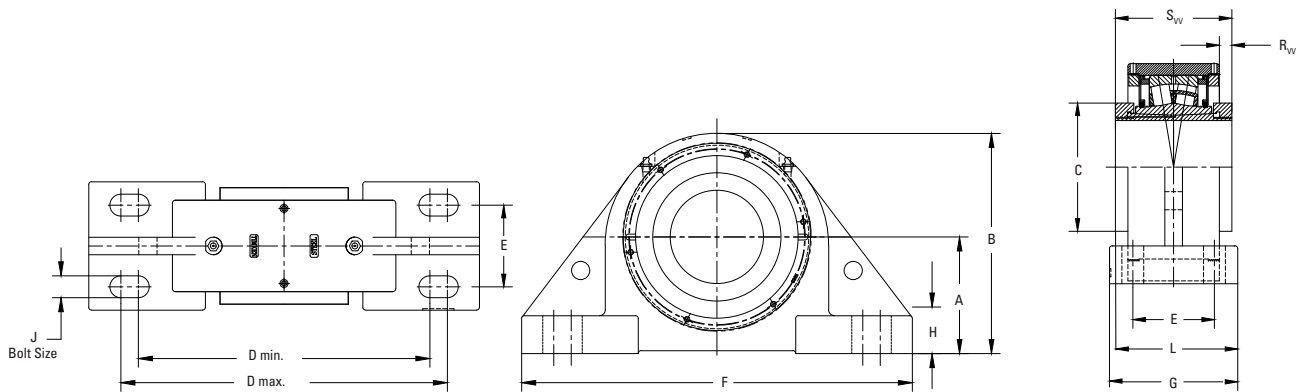

Bearing Part No. ⁽¹⁾	Shaft Dia.	Bearing No.	A	B	C	D min.	D max.	E	F	G	H	J	L	Rvv	Svv	Wt.
	mm in.		mm in.	mm in.	mm in.	mm in.	mm in.	mm in.	mm in.	mm in.	mm in.	mm in.	mm in.	mm in.	mm in.	kg lbs.
QVVPK15V060S	60 mm	22215	88.9 3.50	176.0 6.83	94.0 3.70	230.1 9.06	265.2 10.44	69.9 2.75	330.2 13.00	108.0 4.25	39.1 1.54	20 ¾	105.9 4.17	12.6 0.51	103.9 4.09	13.2 29
QVVPK15V207S	2 7/16 in.															
QVVPK15V208S	2 ½ in.															
QVVPK15V065S	65 mm	22217	101.6 4.00	201.2 7.92	106.4 4.19	274.6 10.81	309.6 12.19	76.2 3.00	381.0 15.00	120.7 4.75	38.1 1.50	20 ¾	113.5 4.47	8.64 0.34	106.2 4.18	16.8 37
QVVPK17V211S	2 11/16 in.															
QVVPK17V212S	2 ¾ in.															
QVVPK17V070S	70 mm	22220	127.0 5.00	240.0 9.44	124.5 4.90	317.5 12.50	355.6 14.00	88.9 3.50	425.5 16.75	139.7 5.50	41.4 1.63	24 7/8	128.8 5.07	8.9 0.35	117.6 4.63	31.8 70
QVVPK20V303S	3 3/16 in.															
QVVPK20V304S	3 ¼ in.															
QVVPK20V080S	80 mm	22222	146.1 5.75	273.8 10.78	139.7 5.50	354.1 13.94	395.2 15.56	101.6 4.00	469.9 18.50	158.8 6.25	45.7 1.80	24 1	138.4 5.45	14.5 0.57	130.3 5.13	39.5 87
QVVPK20V085S	85 mm															
QVVPK20V307S	3 7/16 in.															
QVVPK20V308S	3 ½ in.	22226	155.7 6.13	283.2 11.15	174.8 6.88	387.4 15.25	425.5 16.75	108.0 4.25	514.4 20.25	171.5 6.75	50.8 2.00	24 1	175.3 6.90	31.5 1.24	178.3 7.02	61.7 136
QVVPK20V090S	90 mm															
QVVPK22V311S	3 11/16 in.															
QVVPK22V312S	3 ¾ in.															
QVVPK22V100S	100 mm															
QVVPK22V315S	3 15/16 in.															
QVVPK22V400S	4 in.															
QVVPK26V110S	110 mm															
QVVPK26V407S	4 7/16 in.															
QVVPK26V408S	4 ½ in.															
QVVPK26V115S	115 mm															

⁽¹⁾Double-nut (QVV) part number shown. Single-nut (QV) version available upon request.

QVF AND QVVF SQUARE FLANGE BLOCKS – STRAIGHT BORE EQUIVALENT

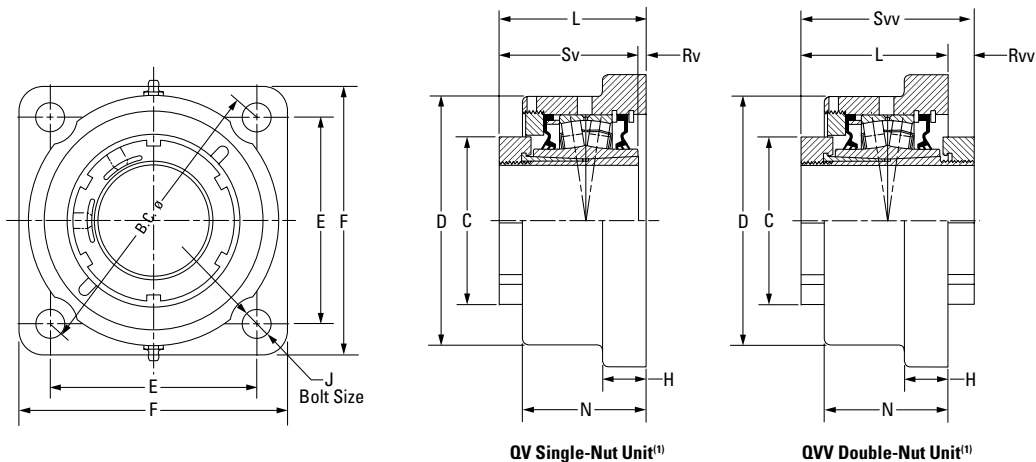

Bearing Part No. ⁽¹⁾⁽²⁾	Shaft Dia.	Bearing No.	C	D	E	B.C.	F	H	J	L	L	N	Rv ⁽¹⁾	Rvv	Sv ⁽¹⁾	Svv	Wt.	
			mm	mm	mm	mm	mm	mm	mm	mm	mm	mm	mm	mm	mm	mm	mm	mm
QVF11V115S	1 15/16 in.	22211	75.9	120.7	111.3	157.0	139.7	22.4	12	84.1	86.1	65.0	4.1	18.3	79.8	102.1	5.0	
QVF11V200S	2 in.		2.99	4.75	4.38	6.18	5.50	0.88	1/2	3.31	3.39	2.56	0.16	0.72	3.14	4.02	11	
QVF11V050S	50 mm																	
QVF12V203S	2 3/16 in.	22212	80.3	130.3	124.0	175.0	157.2	25.4	16	84.3	86.4	66.8	4.6	17.8	79.8	102.1	6.4	
QVF12V204S	2 1/4 in.		3.16	5.13	4.88	6.89	6.19	1.00	5/8	3.32	3.40	2.63	0.18	0.70	3.14	4.02	14	
QVF12V055S	55 mm																	
QVF14V060S	60 mm	22214	94.0	146.1	136.7	193.0	168.4	25.4	16	85.1	87.1	72.4	4.1	16.0	81.0	101.3	7.7	
QVF14V207S	2 7/16 in.		3.70	5.75	5.38	7.60	6.63	1.00	5/8	3.35	3.43	2.85	0.16	0.63	3.19	3.99	17	
QVF14V208S	2 1/2 in.																	
QVF14V065S	65 mm																	
QVF16V211S	2 11/16 in.	22216	106.4	168.9	152.4	215.4	189.0	26.9	20	87.6	89.7	75.7	4.1	16.3	83.6	103.6	10.4	
QVF16V212S	2 3/4 in.		4.19	6.65	6.00	8.48	7.44	1.06	3/4	3.45	3.53	2.98	0.16	0.64	3.29	4.08	23	
QVF16V070S	70 mm																	
QVF16V215S	2 15/16 in.																	
QVF16V300S	3 in.																	
QVF16V075S	75 mm																	
QVF19V303S	3 3/16 in.	22219	124.5	193.8	177.8	251.7	219.2	33.3	20	98.3	100.3	84.1	4.6	15.7	93.7	114.0	15.9	
QVF19V304S	3 1/4 in.		4.90	7.63	7.00	9.91	8.63	1.31	3/4	3.87	3.95	3.31	0.18	0.62	3.69	4.49	35	
QVF19V080S	80 mm																	
QVF19V085S	85 mm																	
QVF19V307S	3 7/16 in.																	
QVF19V308S	3 1/2 in.																	
QVF19V090S	90 mm																	
QVF22V311S	3 11/16 in.	22222	139.7	224.0	196.9	278.4	253.2	38.1	24	114.0	116.1	103.1	9.1	12.7	104.9	126.7	24.9	
QVF22V312S	3 3/4 in.		5.50	8.82	7.75	10.96	9.97	1.50	7/8	4.49	4.57	4.06	0.36	0.50	4.13	4.99	55	
QVF22V100S	100 mm																	
QVF22V315S	3 15/16 in.																	
QVF22V400S	4 in.																	
QVF26V110S	110 mm	22226	174.8	256.8	222.3	314.5	276.4	38.1	24	140.5	142.7	106.9	7.4	37.8	147.8	178.3	28.6	
QVF26V407S	4 7/16 in.		6.88	10.11	8.75	12.38	10.88	1.50	7/8	5.53	5.62	4.21	0.29	1.49	5.82	7.02	63	
QVF26V408S	4 1/2 in.																	
QVF26V115S	115 mm																	

⁽¹⁾Bearing part numbers use QV to designate single-nut units (uses Rv and Sv dimensions) and QVV to designate double-nut units (uses Rvv and Svv dimensions).

⁽²⁾Single-nut (QV) part number shown. Double-nut (QVV) version available upon request.

QVFB AND QVVFB SQUARE FLANGE BLOCKS – TAPERED ADAPTER EQUIVALENT

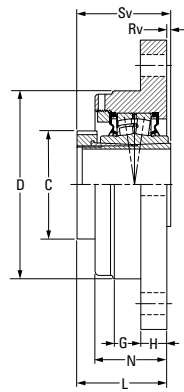
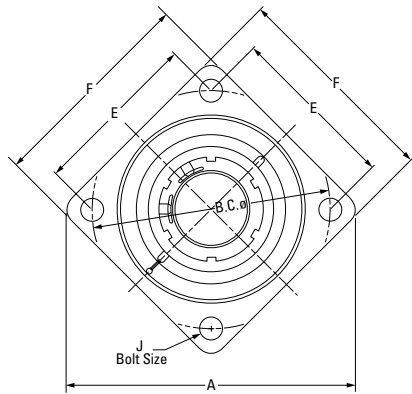

QV Single-Nut Unit⁽¹⁾

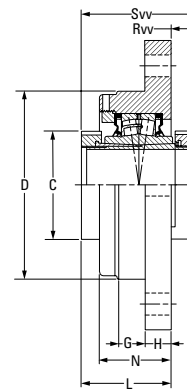

QVV Double-Nut Unit⁽¹⁾

Bearing Part No. ⁽¹⁾⁽²⁾	Shaft Dia.	Bearing No.	A	B.C.	C	D	E	F	G	H	J	L	N	Rv ⁽¹⁾	Rvv	Sv ⁽¹⁾	Svv	Wt.
			mm in.	mm in.	mm in.	mm in.	mm in.	mm in.	mm in.	mm in.	mm in.	mm in.	mm in.	mm in.	mm in.	mm in.	mm in.	mm in.
QVFB15V060S	60 mm	22215	255.0 10.04	215.1 8.47	94.0 3.70	169.9 6.69	152.4 6.00	192.0 7.56	25.4 1.00	23.9 0.94	16 %	81.5 3.21	64.8 2.55	0.8 0.03	22.4 0.88	82.6 3.25	103.9 4.09	11.3 25
QVFB15V207S	2 7/16 in.																	
QVFB15V208S	2 1/2 in.																	
QVFB15V065S	65 mm																	
QVFB17V211S	2 11/16 in.	22217	282.4 11.12	240.0 9.45	106.4 4.19	190.0 7.48	169.7 6.68	212.1 8.35	25.4 1.00	25.4 1.00	16 %	83.8 3.30	69.9 2.75	1.0 0.04	22.4 0.88	84.6 3.33	106.2 4.18	13.6 30
QVFB17V212S	2 3/4 in.																	
QVFB17V070S	70 mm																	
QVFB17V215S	2 9/16 in.																	
QVFB17V300S	3 in.	22220	330.2 13.00	279.9 11.02	124.5 4.90	230.1 9.06	197.9 7.79	247.9 9.76	31.8 1.25	28.7 1.13	20 3/4	106.7 4.20	94.2 3.71	11.4 0.45	10.9 0.43	95.3 3.75	117.3 4.62	18.1 40
QVFB17V075S	75 mm																	
QVFB20V303S	3 3/16 in.																	
QVFB20V304S	3 1/4 in.																	
QVFB20V080S	80 mm	22222	367.0 14.45	309.9 12.20	139.7 5.50	255.0 10.04	219.2 8.63	274.3 10.80	44.5 1.75	26.4 1.04	20 3/4	112.0 4.41	101.1 3.98	7.4 0.29	14.7 0.58	104.9 4.13	126.7 4.99	27.2 60
QVFB20V085S	85 mm																	
QVFB20V307S	3 7/16 in.																	
QVFB20V308S	3 1/2 in.																	
QVFB20V090S	90 mm	22226	416.1 16.38	355.1 13.98	174.8 6.88	290.1 11.42	251.0 9.88	298.5 11.75	41.9 1.65	32.0 1.26	24 %	148.3 5.84	114.3 4.50	0.5 0.02	30.0 1.18	147.8 5.82	178.3 7.02	42.6 94
QVFB22V311S	3 11/16 in.																	
QVFB22V312S	3 3/4 in.																	
QVFB22V100S	100 mm																	
QVFB22V315S	3 15/16 in.																	
QVFB22V400S	4 in.																	
QVFB26V110S	110 mm																	
QVFB26V407S	4 7/16 in.																	
QVFB26V408S	4 1/2 in.																	
QVFB26V115S	115 mm																	

⁽¹⁾Bearing part numbers use QV to designate single-nut units (uses Rv and Sv dimensions) and QVV to designate double-nut units (uses Rvv and Sv dimensions).

⁽²⁾Single-nut (QV) part number shown. Double-nut (QVV) version available upon request.

QVFC AND QVVFC PILOTED FLANGE CARTRIDGES – TAPERED ADAPTER EQUIVALENT

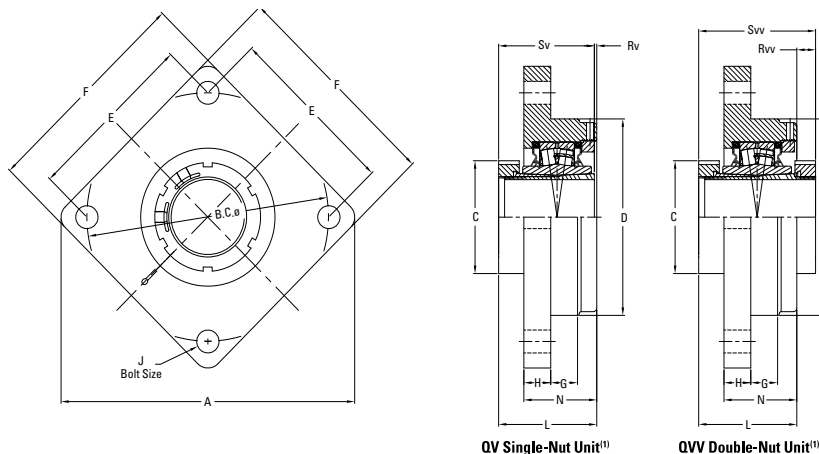

Bearing Part No. ⁽¹⁾⁽²⁾	Shaft Dia.	Bearing No.	A	B.C.	C	D ⁽³⁾	E	F	G	H	J	L	N	Rv ⁽¹⁾	Rvv	Sv ⁽¹⁾	Svv	Wt.	
	mm in.		mm in.	mm in.	mm in.	mm in.	mm in.	mm in.	mm in.	mm in.	mm in.	mm in.	mm in.	mm in.	mm in.	mm in.	mm in.	kg lbs.	
QVFC15V060S	60 mm	22215	255.0 10.04	215.1 8.47	94.0 3.70	169.9 6.690	152.4 6.00	192.0 7.56	25.4 1.00	23.9 0.94	16 %	87.1 3.43	64.8 2.55	4.6 0.18	16.8 0.66	82.6 3.25	103.9 4.09	11.3 25	
QVFC15V207S	2 7/16 in.																		
QVFC15V208S	2 1/2 in.																		
QVFC15V065S	65 mm																		
QVFC17V211S	2 11/16 in.	22217	282.4 11.12	240.0 9.45	106.4 4.19	190.0 7.480	169.7 6.68	212.1 8.35	25.4 1.00	25.4 1.00	16 %	91.7 3.61	69.9 2.75	6.6 0.26	14.5 0.57	84.6 3.33	106.2 4.18	13.6 30	
QVFC17V212S	2 3/4 in.																		
QVFC17V070S	70 mm																		
QVFC17V215S	2 15/16 in.																		
QVFC17V300S	3 in.	22220	330.2 13.00	279.9 11.02	124.5 4.90	230.1 9.060	197.9 7.79	247.9 9.76	31.8 1.25	28.7 1.13	20 3/4	105.2 4.14	94.2 3.71	9.7 0.38	12.4 0.49	95.3 3.75	117.3 4.62	18.1 40	
QVFC17V075S	75 mm																		
QVFC20V303S	3 3/16 in.																		
QVFC20V304S	3 1/4 in.																		
QVFC20V080S	80 mm	22222	367.0 14.45	309.9 12.20	139.7 5.50	255.0 10.040	219.2 8.63	274.3 10.80	44.5 1.75	26.4 1.04	20 3/4	112.8 4.44	101.1 3.98	8.1 0.32	5.8 0.23	104.9 4.13	126.7 4.99	27.2 60	
QVFC20V085S	85 mm																		
QVFC20V307S	3 7/16 in.																		
QVFC20V308S	3 1/2 in.																		
QVFC20V090S	90 mm	22226	416.1 16.38	355.1 13.98	174.8 6.88	290.0 11.417	251.0 9.88	298.5 11.75	41.9 1.65	32.0 1.26	24 %	144.3 5.68	114.3 4.50	3.6 0.14	34.0 1.34	147.8 5.82	178.3 7.02	42.6 94	
QVFC22V311S	3 11/16 in.																		
QVFC22V312S	3 3/4 in.																		
QVFC22V100S	100 mm																		
QVFC22V315S	3 15/16 in.																		
QVFC22V400S	4 in.																		
QVFC26V110S	110 mm																		
QVFC26V407S	4 7/16 in.																		
QVFC26V408S	4 1/2 in.																		
QVFC26V115S	115 mm																		

⁽¹⁾ Bearing part numbers use QV to designate single-nut units (uses Rv and Sv dimensions) and QVV to designate double-nut units (uses Rvv and Svv dimensions).

⁽²⁾ Single-nut (QV) part number shown. Double-nut (QVV) version available upon request.

⁽³⁾ Pilot tolerance: +0/-0.05 mm (+0/-0.002 in.).

QVFL AND QVVFL SQUARE FLANGE BLOCKS – STRAIGHT BORE EQUIVALENT

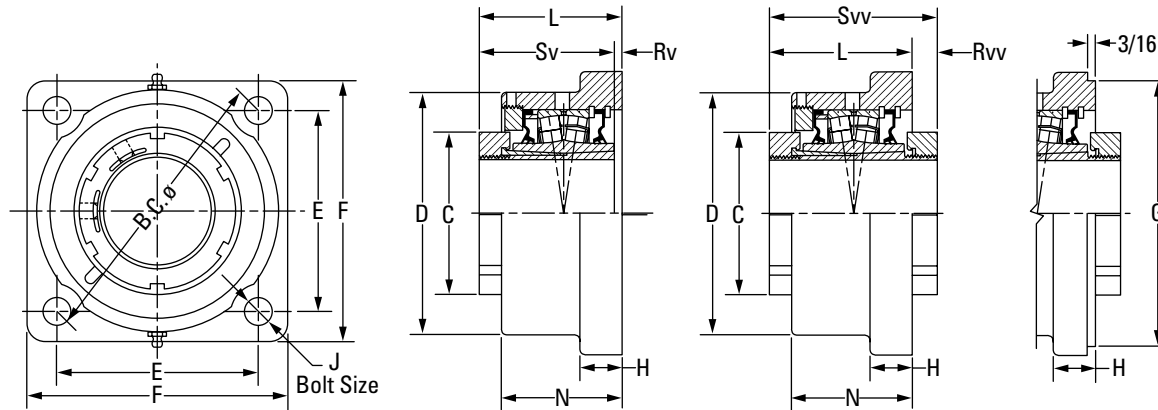

QV Single-Nut Unit⁽¹⁾

QVV Double-Nut Unit⁽¹⁾

Bearing Part No. ⁽¹⁾⁽²⁾	Shaft Dia.	Bearing No.	C	D	E	B.C.	F	G ⁽³⁾⁽⁴⁾⁽⁵⁾	H	J	L FIX	L EXP	N	Rv ⁽¹⁾	Rvv	Sv ⁽¹⁾	Svv	Wt.	
			mm in.	mm in.	mm in.	mm in.	mm in.	mm in.	mm in.	mm in.	mm in.	mm in.	mm in.	mm in.	mm in.	mm in.	mm in.	mm in.	mm in.
QVFL11V115S	1 15/16 in.	22211	75.9	115.3	103.4	146.1	131.8	N/A	23.1	12	82.6	84.6	61.2	2.5	19.8	79.8	102.1	5.0	
QVFL11V200S	2 in.		2.99	4.54	4.07	5.75	5.19		0.91	1/2	3.25	3.33	2.41	0.10	0.78	3.14	4.02	11	
QVFL11V050S	50 mm																		
QVFL12V203S	2 3/16 in.	22212	80.3	130.3	114.6	162.1	149.4	N/A	19.1	16	84.3	86.4	66.8	4.6	17.8	79.8	102.1	6.4	
QVFL12V204S	2 1/4 in.		3.16	5.13	4.51	6.38	5.88		0.75	3/8	3.32	3.40	2.63	0.18	0.70	3.14	4.02	14	
QVFL12V055S	55 mm																		
QVFL14V060S	60 mm	22214	94.0	146.1	121.2	171.5	157.2	N/A	25.4	16	86.1	88.1	72.6	5.1	15.2	81.0	101.3	7.7	
QVFL14V207S	2 7/16 in.		3.70	5.75	4.77	6.75	6.19		1.00	3/8	3.39	3.47	2.86	0.20	0.60	3.19	3.99	17	
QVFL14V208S	2 1/2 in.																		
QVFL14V065S	65 mm																		
QVFL16V211S	2 11/16 in.	22216	106.4	168.4	141.2	200.2	182.6	N/A	26.9	20	86.9	88.9	74.4	3.3	17.0	83.6	103.6	10.4	
QVFL16V212S	2 3/4 in.																		
QVFL16V070S	70 mm		4.19	6.63	5.56	7.88	7.19		1.06	3/4	3.42	3.50	2.93	0.13	0.67	3.29	4.08	23	
QVFL16V215S	2 15/16 in.																		
QVFL16V300S	3 in.																		
QVFL16V075S	75 mm																		
QVFL19V303S	3 3/16 in.	22219	124.5	193.8	170.7	241.3	212.9	187.33	32.5	20	97.3	99.3	86.4	3.6	17.0	93.7	114.0	15.9	
QVFL19V304S	3 1/4 in.		4.90	7.63	6.72	9.50	8.38		7.375	1.28	3/4	3.83	3.91	3.40	0.14	0.67	3.69	4.49	35
QVFL19V080S	80 mm																		
QVFL19V085S	85 mm																		
QVFL19V307S	3 7/16 in.																		
QVFL19V308S	3 1/2 in.																		
QVFL19V090S	90 mm																		
QVFL22V311S	3 11/16 in.	22222	139.7	229.6	193.0	273.1	241.3	215.90	38.1	24	116.8	118.9	104.6	11.9	9.9	104.9	126.7	24.9	
QVFL22V312S	3 3/4 in.		5.50	9.04	7.60	10.75	9.50		8.500	1.50	1	4.60	4.68	4.12	0.47	0.39	4.13	4.99	55
QVFL22V100S	100 mm																		
QVFL22V315S	3 15/16 in.																		
QVFL22V400S	4 in.																		

⁽¹⁾Bearing part numbers use QV to designate single-nut units (uses Rv and Sv dimensions) and QVV to designate double-nut units (uses Rvv and Svv dimensions).

⁽²⁾Single-nut (QV) part number shown. Double-nut (QVV) version available upon request.

⁽³⁾Pilot tolerance: +0/-0.08 mm (+0/-0.003 in.).

⁽⁴⁾Add (p) to the end of the housing designation in the part number to order with pilot using G dimension.

⁽⁵⁾Piloted flange blocks will be quoted (price and delivery) upon request. For optional spigot on flange side, insert the letter P as seen in the following example: QMFP**J***S.

QVFX AND QVVF 5000 SERIES SQUARE FLANGE BLOCKS – STRAIGHT BORE EQUIVALENT

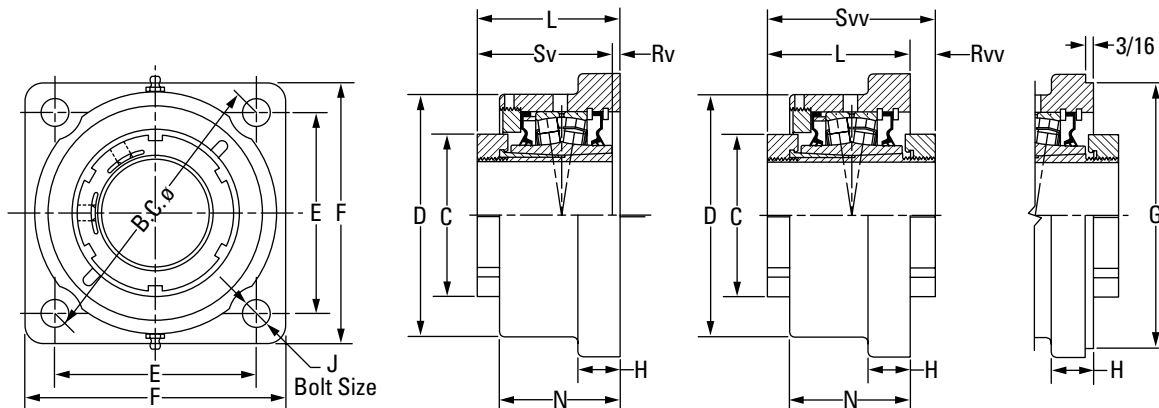

QV Single-Nut Unit⁽¹⁾

QVV Double-Nut Unit⁽¹⁾

Bearing Part No. ⁽¹⁾⁽²⁾	Shaft Dia.	Bearing No.	C	D	E	B.C.	F	G ⁽³⁾⁽⁴⁾⁽⁵⁾	H	J	L FIX	L EXP	N	Rv ⁽¹⁾	Rvv	Sv ⁽¹⁾	Svv	Wt.	
	mm in.		mm in.	mm in.	mm in.	mm in.	mm in.	mm in.	mm in.	mm in.	mm in.	mm in.	mm in.	mm in.	mm in.	mm in.	mm in.	kg lbs.	
QVFX11V115S	1 1/16 in.	22211	75.9	120.7	103.6	146.1	134.9	111.13	22.4	12	84.1	86.1	65.0	4.1	18.3	79.8	102.1	5.0	
QVFX11V200S	2 in.		2.99	4.75	4.08	5.75	5.31	4.375	0.88	1/2	3.31	3.39	2.56	0.16	0.72	3.14	4.02	11	
QVFX11V050S	50 mm																		
QVFX12V203S	2 3/16 in.	22212	80.3	130.3	114.3	161.5	149.4	127.00	25.4	16	84.3	86.4	66.8	4.6	17.5	79.8	102.1	6.4	
QVFX12V204S	2 1/4 in.		3.16	5.13	4.50	6.36	5.88	5.000	1.00	5/8	3.32	3.40	2.63	0.18	0.69	3.14	4.02	14	
QVFX12V055S	55 mm																		
QVFX14V060S	60 mm	22214	94.0	146.1	127.8	180.8	157.2	138.13	25.4	16	85.1	87.4	72.4	4.1	16.0	81.0	101.3	7.7	
QVFX14V207S	2 7/16 in.		3.70	5.75	5.03	7.12	6.19	5.438	1.00	5/8	3.35	3.44	2.85	0.16	0.63	3.19	3.99	17	
QVFX14V208S	2 1/2 in.																		
QVFX14V065S	65 mm																		
QVFX16V211S	2 11/16 in.	22216	106.4	168.9	152.7	215.9	189.0	160.35	26.9	20	87.6	89.7	76.2	4.1	16.3	83.6	103.6	10.4	
QVFX16V212S	2 3/4 in.		4.19	6.65	6.01	8.50	7.44	6.313	1.06	3/4	3.45	3.53	3.00	0.16	0.64	3.29	4.08	23	
QVFX16V070S	70 mm																		
QVFX16V215S	2 15/16 in.																		
QVFX16V300S	3 in.	22219	124.5	193.8	170.7	241.3	212.6	187.33	33.3	20	98.3	100.6	84.1	4.8	15.7	93.7	114.0	15.9	
QVFX16V075S	75 mm		4.90	7.63	6.72	9.50	8.37	7.375	1.31	3/4	3.87	3.96	3.31	0.19	0.62	3.69	4.49	35	
QVFX19V303S	3 3/16 in.																		
QVFX19V304S	3 1/4 in.																		
QVFX19V080S	80 mm																		
QVFX19V085S	85 mm																		
QVFX19V307S	3 7/16 in.																		
QVFX19V308S	3 1/2 in.																		
QVFX19V090S	90 mm	22222	139.7	235.0	211.1	298.5	268.2	225.43	38.1	24	114.0	116.3	100.6	9.4	12.7	104.9	126.7	24.9	
QVFX22V311S	3 11/16 in.		5.50	9.25	8.31	11.75	10.56	8.875	1.50	1	4.49	4.58	3.96	0.37	0.50	4.13	4.99	55	
QVFX22V312S	3 3/4 in.																		
QVFX22V100S	100 mm																		
QVFX22V315S	3 15/16 in.	22226	174.8	254.0	163.6	327.2	384.3	263.53	38.1	24	140.5	142.7	106.9	7.4	37.8	147.8	178.3	49.0	
QVFX26V110S ⁽⁶⁾	110 mm		6.88	10.00	6.44 ⁽⁶⁾	12.88 ⁽⁶⁾	15.13	10.375	1.50	1 ⁽⁶⁾	5.53	5.62	4.21	0.29	1.49	5.82	7.02	108	
QVFX26V407S ⁽⁶⁾	4 7/16 in.																		
QVFX26V408S ⁽⁶⁾	4 1/2 in.																		
QVFX26V115S ⁽⁶⁾	115 mm	22228	190.0	284.2	177.8	355.6	419.1	284.18	38.1	24	166.1	168.1	138.4	18.3	12.2	147.8	178.3	52.2	
QVFX28V125S ⁽⁶⁾	125 mm		7.48	11.19	7.00 ⁽⁶⁾	14.00 ⁽⁶⁾	16.50	11.188	1.50	1 1/8 ⁽⁶⁾	6.54	6.62	5.45	0.72	0.48	5.82	7.02	115	
QVFX28V415S ⁽⁶⁾	4 15/16 in.																		
QVFX28V500S ⁽⁶⁾	5 in.																		
QVFX28V130S ⁽⁶⁾	130 mm																		

⁽¹⁾Bearing part numbers use QV to designate single-nut units (uses Rv and Sv dimensions) and QVV to designate double-nut units (uses Rvv and Svv dimensions).

⁽²⁾Single-nut (QV) part number shown. Double-nut (QVV) version available upon request.

⁽³⁾Pilot tolerance: +0/-0.05 mm (+0/-0.002 in.).

⁽⁴⁾Add (p) to the end of the housing designation in the part number to order with pilot using G dimension.

⁽⁵⁾Piloted flange blocks will be quoted (price and delivery) upon request. For optional spigot on flange side, insert the letter P as seen in the following example: QMFP**J***S.

⁽⁶⁾Six-bolt round housing.

QVFK AND QVVK 9000 SERIES SQUARE FLANGE BLOCKS – TAPERED BORE EQUIVALENT

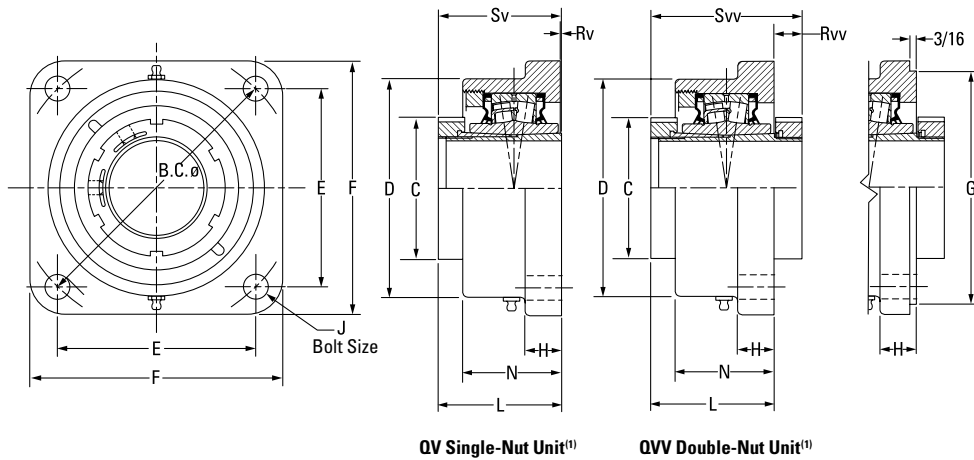

Bearing Part No. ⁽¹⁾⁽²⁾	Shaft Dia.	Bearing No.	C	D	E	B.C.	F	G ⁽³⁾⁽⁴⁾⁽⁵⁾	H	J	L FIX	L EXP	N	Rv ⁽¹⁾	Rvv	Sv ⁽¹⁾	Svv	Wt.
	mm in.		mm in.	mm in.	mm in.	mm in.	mm in.	mm in.	mm in.	mm in.	mm in.	mm in.	mm in.	mm in.	mm in.	mm in.	mm in.	kg lbs.
QVFK11V115S	1 1/8 in.	22211	75.9	130.3	114.3	161.5	149.4	127.00	19.1	16	87.1	88.4	66.8	7.4	15.0	79.8	102.1	5.0
QVFK11V200S	2 in.		2.99	5.13	4.50	6.36	5.88	5.000	0.75	5/8	3.43	3.48	2.63	0.29	0.59	3.14	4.02	11
QVFK11V050S	50 mm																	
QVFK13V203S	2 3/8 in.	22213	80.3	146.1	127.8	180.8	157.2	138.13	25.4	16	92.2	94.2	72.4	6.9	15.5	85.3	107.7	6.4
QVFK13V204S	2 1/4 in.		3.16	5.75	5.03	7.12	6.19	5.438	1.00	5/8	3.63	3.71	2.85	0.27	0.61	3.36	4.24	14
QVFK13V055S	55 mm																	
QVFK15V060S	60 mm	22215	94.0	168.9	152.7	215.9	189.0	160.35	26.9	20	92.5	94.5	76.2	9.9	11.4	82.6	103.9	7.7
QVFK15V207S	2 7/8 in.		3.70	6.65	6.01	8.50	7.44	6.313	1.06	3/4	3.64	3.72	3.00	0.39	0.45	3.25	4.09	17
QVFK15V208S	2 1/2 in.																	
QVFK15V065S	65 mm	22217	106.4	193.8	170.7	241.3	212.9	187.33	33.3	20	92.5	101.1	84.1	14.5	7.1	84.6	106.2	10.4
QVFK17V211S	2 1/8 in.		4.19	7.63	6.72	9.50	8.38	7.375	1.31	3/4	3.64	3.98	3.31	0.57	0.28	3.33	4.18	23
QVFK17V212S	2 3/4 in.																	
QVFK17V070S	70 mm	22220	124.5	215.9	211.1	298.5	268.2	225.43	38.1	24	113.3	115.3	103.1	18.0	4.1	95.3	117.3	15.9
QVFK17V300S	3 in.		4.90	8.50	8.31	11.75	10.56	8.875	1.50	7/8	4.46	4.54	4.06	0.71	0.16	3.75	4.62	35
QVFK17V075S	75 mm																	
QVFK20V303S	3 3/8 in.	22222	139.7	254.0	163.6	327.2	384.3	263.53	31.8	24	117.3	119.4	106.9	12.4	9.7	104.9	126.7	24.9
QVFK20V304S	3 1/4 in.		5.50	10.00	6.44 ⁽⁶⁾	12.88 ⁽⁶⁾	15.13	10.375	1.25	1 ⁽⁶⁾	4.62	4.70	4.21	0.49	0.38	4.13	4.99	55
QVFK20V080S	80 mm																	
QVFK20V085S	85 mm	22226	174.8	284.2	177.8	355.6	419.1	284.18	38.1	24	164.6	166.6	135.1	11.7	13.7	147.8	178.3	49.0
QVFK20V307S	3 7/8 in.		6.88	11.19	7.00 ⁽⁶⁾	14.00 ⁽⁶⁾	16.50	11.188	1.50	1 ⁽⁶⁾	6.48	6.56	5.32	0.46	0.54	5.82	7.02	108
QVFK20V308S	3 1/2 in.																	
QVFK20V090S	90 mm																	
QVFK22V3115 ⁽⁶⁾	3 1/8 in.	22226	174.8	284.2	177.8	355.6	419.1	284.18	38.1	24	164.6	166.6	135.1	11.7	13.7	147.8	178.3	49.0
QVFK22V3125 ⁽⁶⁾	3 3/4 in.		6.88	11.19	7.00 ⁽⁶⁾	14.00 ⁽⁶⁾	16.50	11.188	1.50	1 ⁽⁶⁾	6.48	6.56	5.32	0.46	0.54	5.82	7.02	108
QVFK22V1005 ⁽⁶⁾	100 mm																	
QVFK22V3155 ⁽⁶⁾	3 1/8 in.																	
QVFK22V4005 ⁽⁶⁾	4 in.																	
QVFK26V1105 ⁽⁶⁾	110 mm																	
QVFK26V4075 ⁽⁶⁾	4 7/8 in.																	
QVFK26V4085 ⁽⁶⁾	4 1/2 in.																	
QVFK26V1155 ⁽⁶⁾	115 mm																	

⁽¹⁾Bearing part numbers use QV to designate single-nut units (uses Rv and Sv dimensions) and QVV to designate double-nut units (uses Rvv and Sv dimensions).

⁽²⁾Single-nut (QV) part number shown. Double-nut (QVV) version available upon request.

⁽³⁾Pilot tolerance: +0/-0.05 mm (+0/-0.002 in.).

⁽⁴⁾Add (p) to the end of the housing designation in the part number to order with pilot using G dimension.

⁽⁵⁾Piloted flange blocks will be quoted (price and delivery) upon request. For optional spigot on flange side, insert the letter P as seen in the following example: QMFP**J***S.

⁽⁶⁾Six-bolt round housing.

QVFNL SERIES SQUARE FLANGE BLOCKS – STRAIGHT BORE EQUIVALENT

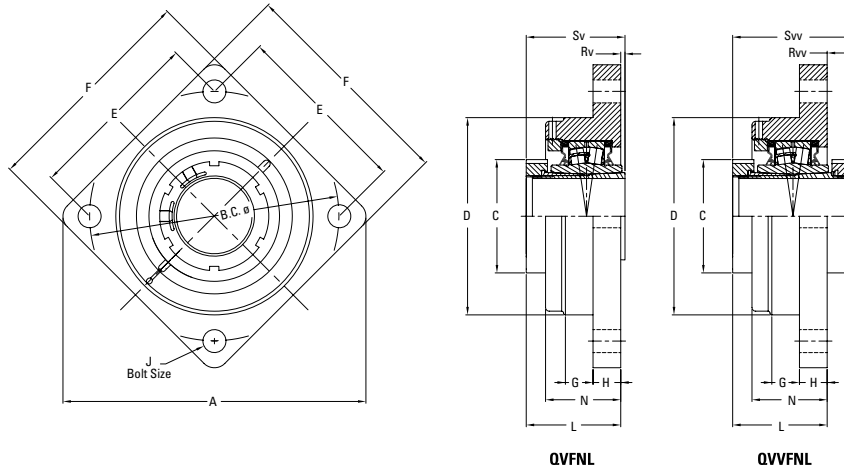

Bearing Part No. ⁽¹⁾⁽²⁾	Shaft Dia.	Bearing No.	A	B.C.	C	D	E	F	G	H	J	L	N	Rv	Rvv	Sv	Svv	Wt.
	mm in.		mm in.	mm in.	mm in.	mm in.	mm in.	mm in.	mm in.	mm in.	mm in.	mm in.	mm in.	mm in.	mm in.	mm in.	mm in.	kg lbs.
QVFNL15V207S	2 7/16 in.	22215	255.0	215.0	94.0	170.0	152.0	192.0	25.4	23.9	16	81.5	64.8	0.8	22.4	82.6	103.9	11.3
QVFNL15V208S	2 1/2 in.		10.04	8.47	3.70	6.69	6.00	7.56	1.00	0.94	3/8	3.21	2.55	0.03	0.88	3.25	4.09	25
QVFNL15V065S	65 mm																	
QVFNL16V211S	2 13/16 in.	22216	255.0	215.0	106.4	170.0	152.0	192.0	25.4	23.9	16	81.5	64.8	2.0	22.4	83.6	103.6	11.3
QVFNL16V212S	2 3/4 in.		10.04	8.47	4.19	6.69	6.00	7.56	1.00	0.94	3/8	3.21	2.55	0.08	0.88	3.29	4.08	25
QVFNL16V070S	70 mm																	
QVFNL17V215S	2 15/16 in.	22217	282.0	240.0	106.4	190.0	170.0	212.0	25.4	25.4	16	83.8	69.9	1.0	22.4	84.6	106.2	13.6
QVFNL17V300S	3 in.		11.12	9.45	4.19	7.48	6.68	8.35	1.00	1.00	3/8	3.30	2.75	0.04	0.88	3.33	4.18	30
QVFNL17V075S	75 mm																	
QVFNL19V303S	3 3/16 in.	22219	282.0	240.0	124.5	190.0	170.0	212.0	25.4	25.4	16	87.9	69.9	5.8	26.4	93.7	114.0	13.6
QVFNL19V304S	3 1/4 in.		11.12	9.45	4.90	7.48	6.68	8.35	1.00	1.00	3/8	3.46	2.75	0.23	1.04	3.69	4.49	30
QVFNL19V080S	80 mm																	
QVFNL20V307S	3 7/16 in.	22220	330.0	280.0	124.5	230.0	198.0	248.0	31.8	28.7	20	106.7	94.2	11.4	10.9	95.3	117.3	18.1
QVFNL20V308S	3 1/2 in.		13.00	11.02	4.90	9.06	7.79	9.76	1.25	1.13	3/4	4.20	3.71	0.45	0.43	3.75	4.62	40
QVFNL20V090S	90 mm																	
QVFNL22V315S	3 15/16 in.	22222	367.0	309.9	139.7	255.0	219.0	280.0	44.5	26.4	20	112.0	101.1	7.4	14.7	104.9	126.7	27.2
QVFNL22V400S	4 in.		14.45	12.20	5.50	10.04	8.63	11.00	1.75	1.04	3/4	4.41	3.98	0.29	0.58	4.13	4.99	60
QVFNL22V100S	100 mm																	

⁽¹⁾Bearing part numbers use QV to designate single-nut units (uses Rv and Sv dimensions) and QVV to designate double-nut units (uses Rvv and Sv dimensions).

⁽²⁾Single-nut (QV) part number shown. Double-nut (QVV) version available upon request.

QVfy AND QVfy ROUND FLANGE BLOCKS – STRAIGHT BORE EQUIVALENT

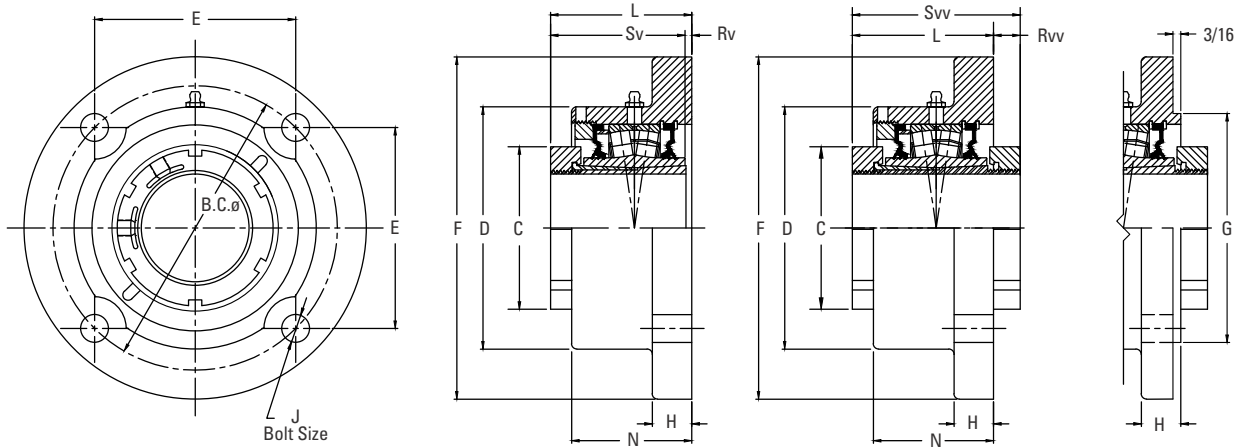

Bearing Part No. ⁽¹⁾⁽²⁾	Shaft Dia.	Bearing No.	C	D	E	B.C.	F	G ⁽³⁾⁽⁴⁾⁽⁵⁾	H	J	L FIX	L EXP	N	Rv ⁽¹⁾	Rvv	Sv ⁽¹⁾	Svv	Wt.
			mm in.	mm in.	mm in.	mm in.	mm in.	mm in.	mm in.	mm in.	mm in.	mm in.	mm in.	mm in.	mm in.	mm in.	mm in.	mm in.
QVfy11V115S	1 15/16 in.	22211	75.9	115.3	103.4	146.1	177.8	111.13	19.1	12	78.5	80.5	58.4	1.5	23.9	79.8	102.1	5.4
QVfy11V200S	2 in.		2.99	4.54	4.07	5.75	7.00	4.375	0.75	1/2	3.09	3.17	2.30	0.06	0.94	3.14	4.02	12
QVfy11V050S	50 mm																	
QVfy12V203S	2 3/8 in.	22212	80.3	130.3	114.6	162.1	196.9	127.00	19.1	16	80.0	82.0	62.0	0.3	22.1	79.8	102.1	6.8
QVfy12V204S	2 1/4 in.		3.16	5.13	4.51	6.38	7.75	5.000	0.75	5/8	3.15	3.23	2.44	0.01	0.87	3.14	4.02	15
QVfy12V055S	55 mm																	
QVfy14V060S	60 mm	22214	94.0	146.1	121.2	171.5	206.5	138.13	23.9	16	84.8	86.9	72.4	3.8	16.5	81.0	101.3	8.6
QVfy14V207S	2 7/8 in.		3.70	5.75	4.77	6.75	8.13	5.438	0.94	5/8	3.34	3.42	2.85	0.15	0.65	3.19	3.99	19
QVfy14V208S	2 1/2 in.																	
QVfy14V065S	65 mm																	
QVfy16V211S	2 11/16 in.	22216	106.4	168.4	141.5	199.9	241.3	160.35	23.9	20	88.4	90.4	76.2	4.8	15.2	83.6	103.6	12.7
QVfy16V212S	2 3/4 in.		4.19	6.63	5.57	7.87	9.50	6.313	0.94	3/4	3.48	3.56	3.00	0.19	0.60	3.29	4.08	28
QVfy16V070S	70 mm																	
QVfy16V215S	2 15/16 in.																	
QVfy16V300S	3 in.																	
QVfy16V075S	75 mm																	
QVfy19V303S	3 3/16 in.	22219	124.5	193.8	170.7	241.3	282.7	187.33	28.7	24	98.3	116.1	85.3	4.8	15.7	93.7	114.0	19.1
QVfy19V304S	3 1/4 in.		4.90	7.63	6.72	9.50	11.13	7.375	1.13	7/8	3.87	4.57	3.36	0.19	0.62	3.69	4.49	42
QVfy19V080S	80 mm																	
QVfy19V085S	85 mm																	
QVfy19V307S	3 7/8 in.																	
QVfy19V308S	3 1/2 in.																	
QVfy19V090S	90 mm																	
QVfy22V311S	3 11/16 in.	22222	139.7	222.5	193.0	273.1	320.8	N/A	28.7	24	115.3	117.3	103.1	10.4	11.4	104.9	126.7	29.9
QVfy22V312S	3 3/4 in.		5.50	8.76	7.60	10.75	12.63		1.13	1	4.54	4.62	4.06	0.41	0.45	4.13	4.99	66
QVfy22V100S	100 mm																	
QVfy22V315S	3 15/16 in.																	
QVfy22V400S	4 in.																	
QVfy26V110S ⁽⁶⁾	110 mm	22226	174.8	230.1	163.6	327.2	384.3	N/A	38.1	24	140.5	142.7	106.9	7.4	37.8	147.8	178.3	49.0
QVfy26V407S ⁽⁶⁾	4 7/8 in.		6.88	9.06	6.44 ⁽⁶⁾	12.88 ⁽⁶⁾	15.13		1.50	1 ⁽⁶⁾	5.53	5.62	4.21	0.29	1.49	5.82	7.02	108
QVfy26V408S ⁽⁶⁾	4 1/2 in.																	
QVfy26V115S ⁽⁶⁾	115 mm																	
QVfy28V125S ⁽⁶⁾	125 mm																	
QVfy28V415S ⁽⁶⁾	4 15/16 in.	22228	190.0	284.2	177.8	355.6	419.1	N/A	38.1	24	166.1	168.1	138.4	18.3	12.2	147.8	178.3	52.2
QVfy28V500S ⁽⁶⁾	5 in.		7.48	11.19	7.00 ⁽⁶⁾	14.00 ⁽⁶⁾	16.50		1.50	1 1/8 ⁽⁶⁾	6.54	6.62	5.45	0.72	0.48	5.82	7.02	115
QVfy28V130S ⁽⁶⁾	130 mm																	

⁽¹⁾Bearing part numbers use QV to designate single-nut units (uses Rv and Sv dimensions) and QVV to designate double-nut units (uses Rvv and Svv dimensions).

⁽²⁾Single-nut (QV) part number shown. Double-nut (QVV) version available upon request.

⁽³⁾Pilot tolerance: +0/-0.05 mm (+0/-0.002 in.).

⁽⁴⁾Add (p) to the end of the housing designation in the part number to order with pilot using G dimension.

⁽⁵⁾Piloted flange blocks will be quoted (price and delivery) upon request. For optional spigot on flange side, insert the letter P as seen in the following example: QMFP**J***S.

⁽⁶⁾Six-bolt round housing.

QVC AND QVVC PILOTED FLANGE CARTRIDGES – STRAIGHT BORE EQUIVALENT

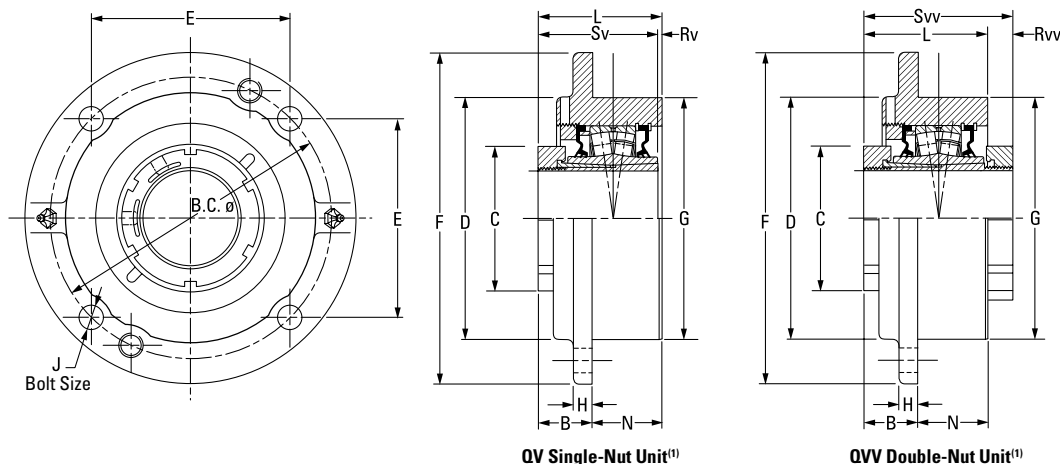

Bearing Part No. ⁽¹⁾⁽²⁾	Shaft Dia.	Bearing No.	B FIX	B EXP	C	D	B.C.	E	F	G ⁽³⁾	H	J	L	N	Rv ⁽¹⁾	Rvv	Sv ⁽¹⁾	Svv	Wt.	
	mm in.		mm in.	mm in.	mm in.	mm in.	mm in.	mm in.	mm in.	mm in.	mm in.	mm in.	mm in.	mm in.	mm in.	mm in.	mm in.	mm in.	mm in.	kg lbs.
QVC11V115S	1 15/16 in.	22211	53.8	55.9	75.9	113.5	136.7	96.5	162.1	114.3	16.0	10	80.8	26.9	0.8	21.6	79.8	102.1	4.5	
QVC11V200S	2 in.		2.12	2.20	2.99	4.47	5.38	3.80	6.38	4.50	0.63	7/16	3.18	1.06	0.03	0.85	3.14	4.02	10	
QVC11V050S	50 mm																			
QVC12V203S	2 3/8 in.	22212	51.3	53.3	80.3	127.0	152.4	107.7	185.4	127.0	14.7	12	80.0	28.7	0.3	22.1	79.8	102.1	5.9	
QVC12V204S	2 1/4 in.		2.02	2.10	3.16	5.00	6.00	4.24	7.30	5.00	0.58	1/2	3.15	1.13	0.01	0.87	3.14	4.02	13	
QVC12V055S	55 mm																			
QVC14V060S	60 mm	22214	56.1	58.2	94.0	139.7	165.1	116.8	193.8	139.7	17.5	12	84.6	28.7	3.8	16.5	81.0	101.3	7.3	
QVC14V207S	2 7/8 in.		2.21	2.29	3.70	5.50	6.50	4.60	7.63	5.50	0.69	1/2	3.33	1.13	0.15	0.65	3.19	3.99	16	
QVC14V208S	2 1/2 in.																			
QVC14V065S	65 mm																			
QVC16V211S	2 11/16 in.	22216	52.8	54.9	106.4	162.1	190.5	134.6	222.3	161.9	20.6	16	84.6	31.8	1.0	19.3	83.6	103.6	10.0	
QVC16V212S	2 3/4 in.		2.08	2.16	4.19	6.38	7.50	5.30	8.75	6.36	0.81	5/8	3.33	1.25	0.04	0.76	3.29	4.08	22	
QVC16V070S	70 mm																			
QVC16V215S	2 15/16 in.		2.08	2.16	4.19	6.38	7.50	5.30	8.75	6.36	0.81	5/8	3.33	1.25	0.04	0.76	3.29	4.08	22	
QVC16V300S	3 in.																			
QVC16V075S	75 mm																			
QVC19V303S	3 3/16 in.	22219	62.5	64.5	124.5	199.1	219.2	154.9	262.6	187.3	25.4	20	95.8	33.3	2.0	18.5	93.7	114.0	14.5	
QVC19V304S	3 1/4 in.		2.46	2.54	4.90	7.84	8.63	6.10	10.34	7.38	1.00	3/4	3.77	1.31	0.08	0.73	3.69	4.49	32	
QVC19V080S	80 mm																			
QVC19V085S	85 mm																			
QVC19V307S	3 7/16 in.																			
QVC19V308S	3 1/2 in.																			
QVC19V090S	90 mm																			
QVC22V311S	3 11/16 in.	22222	60.2	62.2	139.7	222.5	238.3	168.4	276.4	206.4	25.4	20	115.3	54.1	10.4	11.7	104.9	126.7	19.5	
QVC22V312S	3 3/4 in.		2.37	2.45	5.50	8.76	9.38	6.63	10.88	8.13	1.00	3/4	4.54	2.13	0.41	0.46	4.13	4.99	43	
QVC22V100S	100 mm																			
QVC22V315S	3 15/16 in.																			
QVC22V400S	4 in.																			
QVC26V110S ⁽⁴⁾	110 mm	22226	86.4	88.4	174.8	260.4	298.5	149.4	342.9	260.4	25.4	20	134.6	48.3	13.2	43.7	147.8	178.3	32.7	
QVC26V407S ⁽⁴⁾	4 7/8 in.		3.40	3.48	6.88	10.25	11.75 ⁽⁴⁾	5.88 ⁽⁴⁾	13.50	10.25	1.00	3/4 ⁽⁴⁾	5.30	1.90	0.52	1.72	5.82	7.02	72	
QVC26V408S ⁽⁴⁾	4 1/2 in.																			
QVC26V115S ⁽⁴⁾	115 mm																			

⁽¹⁾Bearing part numbers use QV to designate single-nut units (uses Rv and Sv dimensions) and QVV to designate double-nut units (uses Rvv and Svv dimensions).

⁽²⁾Single-nut (QV) part number shown. Double-nut (QVV) version available upon request.

⁽³⁾Pilot tolerance: +0/-0.05 mm (+0/-0.002 in.).

⁽⁴⁾Six-bolt round housing.

QVCW AND QVVCW PILOTED FLANGE CARTRIDGES – STRAIGHT BORE EQUIVALENT

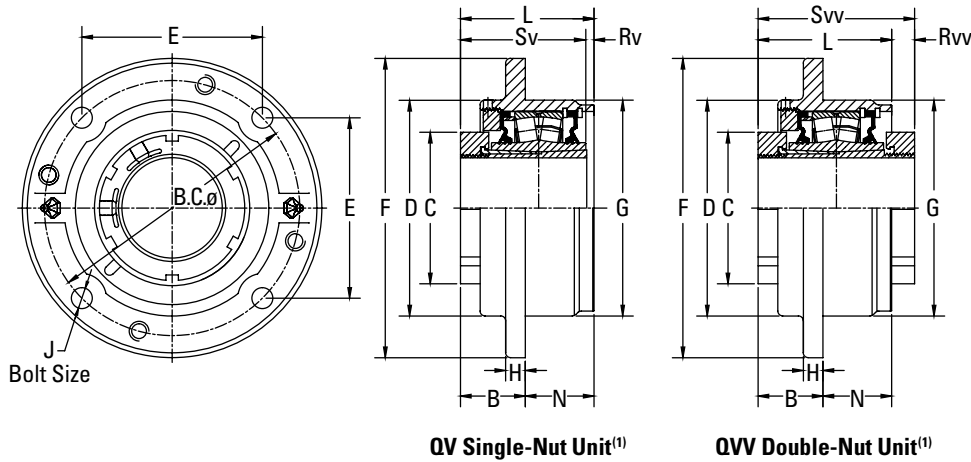

QV Single-Nut Unit⁽¹⁾

QVV Double-Nut Unit⁽¹⁾

Bearing Part No. ⁽¹⁾⁽²⁾	Shaft Dia.	Bearing No.	B FIX	B EXP	C	D	B.C.	E	F	G ⁽³⁾	H	J	L	N	Rv ⁽¹⁾	Rvv	Sv ⁽¹⁾	Svv	Wt.	
	mm in.		mm in.	mm in.	mm in.	mm in.	mm in.	mm in.	mm in.	mm in.	mm in.	mm in.	mm in.	mm in.	mm in.	mm in.	mm in.	mm in.	mm in.	kg lbs.
QVCW11V115S	1 15/16 in.	22211	42.2	44.2	75.9	113.5	136.7	96.5	162.1	114.3	9.7	10	80.3	38.1	0.8	21.8	79.8	102.1	4.5	
QVCW11V200S	2 in.		1.66	1.74	2.99	4.47	5.38	3.80	6.38	4.50	0.38	7/16	3.16	1.50	0.03	0.86	3.14	4.02	10	
QVCW11V050S	50 mm																			
QVCW12V203S	2 3/8 in.	22212	43.2	45.5	80.3	126.7	152.4	107.7	181.1	127.0	14.2	12	84.6	41.4	4.8	17.5	79.8	102.1	5.9	
QVCW12V204S	2 1/4 in.		1.70	1.79	3.16	4.99	6.00	4.24	7.13	5.00	0.56	1/2	3.33	1.63	0.19	0.69	3.14	4.02	13	
QVCW12V055S	55 mm																			
QVCW14V060S	60 mm	22214	41.9	43.9	94.0	139.7	165.1	116.8	193.8	139.7	12.7	12	86.4	42.9	5.3	15.0	81.0	101.3	7.3	
QVCW14V207S	2 7/8 in.		1.65	1.73	3.70	5.50	6.50	4.60	7.63	5.50	0.50	1/2	3.40	1.69	0.21	0.59	3.19	3.99	16	
QVCW14V208S	2 1/2 in.																			
QVCW14V065S	65 mm																			
QVCW16V211S	2 1/8 in.	22216	37.6	39.6	106.4	162.1	190.5	134.6	222.3	161.9	12.7	16	85.1	47.8	1.8	18.5	83.6	103.6	10.0	
QVCW16V212S	2 3/4 in.		1.48	1.56	4.19	6.38	7.50	5.30	8.75	6.36	0.50	5/8	3.35	1.88	0.07	0.73	3.29	4.08	22	
QVCW16V070S	70 mm																			
QVCW16V215S	2 15/16 in.																			
QVCW16V300S	3 in.																			
QVCW16V075S	75 mm																			
QVCW19V303S	3 3/8 in.	22219	49.8	51.8	124.5	199.1	219.2	154.9	260.4	187.3	22.4	20	97.5	47.8	3.8	16.8	93.7	114.0	14.5	
QVCW19V304S	3 1/4 in.		1.96	2.04	4.90	7.84	8.63	6.10	10.25	7.36	0.88	3/4	3.84	1.88	0.15	0.66	3.69	4.49	32	
QVCW19V080S	80 mm																			
QVCW19V085S	85 mm																			
QVCW19V307S	3 7/8 in.																			
QVCW19V308S	3 1/2 in.																			
QVCW19V090S	90 mm																			
QVCW22V311S	3 11/16 in.	22222	51.6	53.6	139.7	222.5	238.3	168.4	276.4	206.4	25.4	20	109.7	57.2	4.8	17.3	104.9	126.7	19.5	
QVCW22V312S	3 3/4 in.		2.03	2.11	5.50	8.76	9.38	6.63	10.88	8.13	1.00	3/4	4.32	2.25	0.19	0.68	4.13	4.99	43	
QVCW22V100S	100 mm																			
QVCW22V315S	3 15/16 in.																			
QVCW22V400S	4 in.																			
QVCW26V110S ⁽⁴⁾	110 mm	22226	72.4	74.4	174.8	260.4	298.5	149.4	342.9	260.4	25.4	20	140.5	68.3	7.4	37.8	147.8	178.3	32.7	
QVCW26V407S ⁽⁴⁾	4 7/8 in.		2.85	2.93	6.88	10.25	11.75 ⁽⁴⁾	5.88 ⁽⁴⁾	13.50	10.25	1.00 ⁽⁴⁾	3/4	5.53	2.69	0.29	1.49	5.82	7.02	72	
QVCW26V408S ⁽⁴⁾	4 1/2 in.																			
QVCW26V115S ⁽⁴⁾	115 mm																			
QVCW28V125S ⁽⁴⁾	125 mm																			
QVCW28V415S ⁽⁴⁾	4 15/16 in.	22228	66.5	68.6	190.0	266.7	323.9	162.1	374.7	279.4	26.2	24	144.5	78.0	3.3	33.8	147.8	178.3	46.3	
QVCW28V500S ⁽⁴⁾	5 in.		2.62	2.70	7.48	10.50	12.75 ⁽⁴⁾	6.38 ⁽⁴⁾	14.75	11.00	1.03 ⁽⁴⁾	7/8	5.69	3.07	0.13	1.33	5.82	7.02	102	
QVCW28V130S ⁽⁴⁾	130 mm																			

⁽¹⁾Bearing part numbers use QV to designate single-nut units (uses Rv and Sv dimensions) and QVV to designate double-nut units (uses Rvv and Svv dimensions).

⁽²⁾Single-nut (QV) part number shown. Double-nut (QVV) version available upon request.

⁽³⁾Pilot tolerance: +0/-0.05 mm (+0/-0.002 in.).

⁽⁴⁾Six-bolt round housing.

QVMC AND QVVMC CARTRIDGE BLOCKS – TAPERED BORE EQUIVALENT

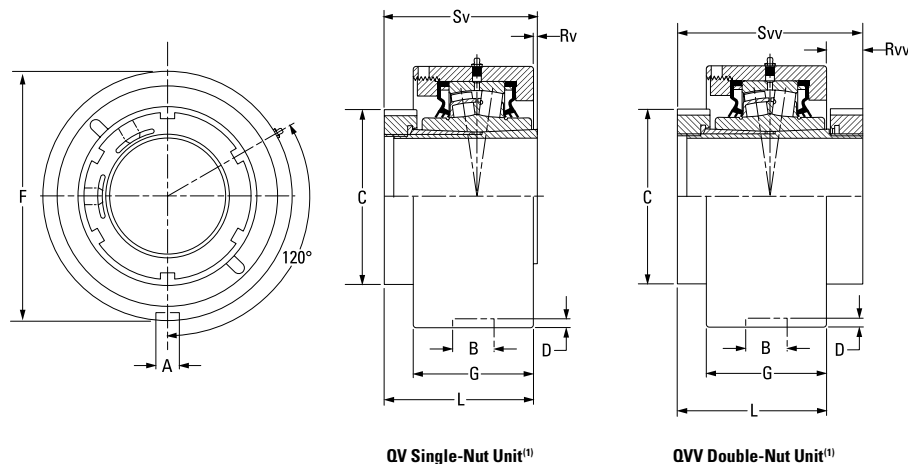

Bearing Part No. ⁽¹⁾⁽²⁾	Shaft Dia.	Bearing No.	A	B	C	D	F	G	L	L	Rv ⁽¹⁾	Rvv	Sv ⁽¹⁾	Svv	Wt.
			mm in.	mm in.	mm in.	mm in.	mm in.	mm in.	mm in.	mm in.	mm in.	mm in.	mm in.	mm in.	mm in.
QVMC11V115S	1 15/16 in.	22211	13.5	23.0	75.9	4.8	115.09 (+0/-0.05)	55.4	79.0	81.0	0.8	23.1	79.8	102.1	4.5
QVMC11V200S	2 in.		0.530	0.91	2.99	0.19	4.53 (+0/-0.002)	2.18	3.11	3.19	0.03	0.91	3.14	4.02	10
QVMC11V050S	50 mm														
QVMC13V203S	2 3/8 in.	22213	13.5	23.0	80.3	4.8	127.00 (+0/-0.05)	67.1	85.9	87.9	0.5	21.8	85.3	107.7	5.4
QVMC13V204S	2 1/4 in.		0.530	0.91	3.16	0.19	5.00 (+0/-0.002)	2.64	3.38	3.46	0.02	0.86	3.36	4.24	12
QVMC13V055S	55 mm														
QVMC15V060S	60 mm	22215	15.1	26.2	94.0	6.4	149.23 (+0/-0.05)	70.6	87.4	89.4	5.1	16.5	82.6	103.9	8.2
QVMC15V207S	2 7/8 in.		0.594	1.03	3.70	0.25	5.86 (+0/-0.002)	2.78	3.44	3.52	0.20	0.65	3.25	4.09	18
QVMC15V208S	2 1/2 in.														
QVMC15V065S	65 mm	22217	15.1	27.5	106.4	7.1	171.45 (+0/-0.05)	74.9	91.2	93.2	6.4	15.0	84.6	106.2	11.8
QVMC17V211S	2 11/16 in.		0.594	1.08	4.19	0.28	6.75 (+0/-0.002)	2.95	3.59	3.67	0.25	0.59	3.33	4.18	26
QVMC17V212S	2 3/4 in.														
QVMC17V070S	70 mm	22220	19.8	32.5	124.5	8.0	206.38 (+0/-0.05)	85.6	102.1	104.1	6.9	15.2	95.3	117.3	14.5
QVMC17V215S	2 5/8 in.		0.781	1.28	4.90	0.31	8.13 (+0/-0.002)	3.37	4.02	4.10	0.27	0.60	3.75	4.62	32
QVMC17V300S	3 in.														
QVMC17V075S	75 mm	22222	19.8	32.5	139.7	8.0	222.25 (+0/-0.08)	97.8	113.0	115.1	8.1	14.0	104.9	126.7	18.1
QVMC20V303S	3 3/8 in.		0.781	1.28	5.50	0.31	8.75 (+0/-0.003)	3.85	4.45	4.53	0.32	0.55	4.13	4.99	40
QVMC20V304S	3 1/4 in.														
QVMC20V080S	80 mm	22226	19.8	38.1	174.8	8.0	265.10 (+0/-0.08)	104.4	141.5	143.5	6.4	36.8	147.8	178.3	23.6
QVMC20V085S	85 mm		0.781	1.50	6.88	0.31	10.44 (+0/-0.003)	4.11	5.57	5.65	0.25	1.45	5.82	7.02	52
QVMC20V307S	3 7/8 in.														
QVMC20V308S	3 1/2 in.	22226	19.8	38.1	174.8	8.0	265.10 (+0/-0.08)	104.4	141.5	143.5	6.4	36.8	147.8	178.3	23.6
QVMC20V090S	90 mm		0.781	1.50	6.88	0.31	10.44 (+0/-0.003)	4.11	5.57	5.65	0.25	1.45	5.82	7.02	52
QVMC22V311S	3 11/16 in.														
QVMC22V312S	3 3/4 in.	22226	19.8	38.1	174.8	8.0	265.10 (+0/-0.08)	104.4	141.5	143.5	6.4	36.8	147.8	178.3	23.6
QVMC22V100S	100 mm		0.781	1.50	6.88	0.31	10.44 (+0/-0.003)	4.11	5.57	5.65	0.25	1.45	5.82	7.02	52
QVMC22V315S	3 15/16 in.														
QVMC22V400S	4 in.	22226	19.8	38.1	174.8	8.0	265.10 (+0/-0.08)	104.4	141.5	143.5	6.4	36.8	147.8	178.3	23.6
QVMC26V110S	110 mm		0.781	1.50	6.88	0.31	10.44 (+0/-0.003)	4.11	5.57	5.65	0.25	1.45	5.82	7.02	52
QVMC26V407S	4 7/8 in.														
QVMC26V408S	4 1/2 in.	22226	19.8	38.1	174.8	8.0	265.10 (+0/-0.08)	104.4	141.5	143.5	6.4	36.8	147.8	178.3	23.6
QVMC26V115S	115 mm		0.781	1.50	6.88	0.31	10.44 (+0/-0.003)	4.11	5.57	5.65	0.25	1.45	5.82	7.02	52

⁽¹⁾Bearing part numbers use QV to designate single-nut units (uses Rv and Sv dimensions) and QVV to designate double-nut units (uses Rvv and Sv dimensions).

⁽²⁾Single-nut (QV) part number shown. Double-nut (QVV) version available upon request.

QVVTU TAKE-UP BLOCKS – STRAIGHT BORE EQUIVALENT

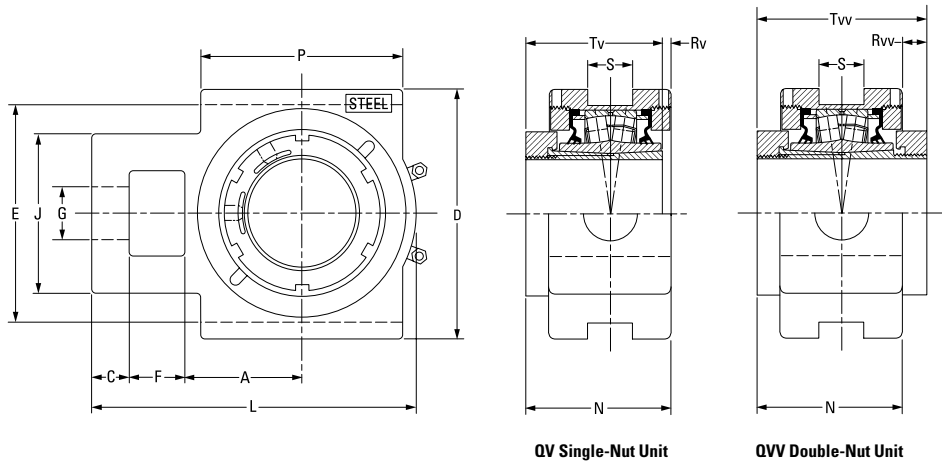

Bearing Part No. ⁽¹⁾	Shaft Dia.	Bearing No.	A	C	D	E	F	G	J	L	N	P	S	Rv ⁽¹⁾	Rv'	Tv ⁽¹⁾	Tv'	Wt.	
	mm in.		mm in.	mm in.	mm in.	mm in.	mm in.	mm in.	mm in.	mm in.	mm in.	mm in.	mm in.	mm in.	mm in.	mm in.	mm in.	kg lbs.	
QVVTU14V060S	60 mm	22214	69.9 2.75	22.4 0.88	149.4 5.88	130.3 5.13	33.3 1.31	35.1 1.38	95.3 3.75	193.8 7.63	88.4 3.48	120.7 4.75	26.9 1.06	3.3 0.13	15.5 0.61	85.1 3.35	103.9 4.09	7.7 17	
QVVTU14V207S	2 7/16 in.																		
QVVTU14V208S	2 1/2 in.																		
QVVTU14V065S	65 mm																		
QVVTU16V211S	2 1/16 in.	22216	76.2 3.00	25.4 1.00	171.5 6.75	150.9 5.94	39.6 1.56	39.6 1.56	108.0 4.25	219.7 8.65	90.2 3.55	120.7 4.75	46.0 1.81	2.3 0.09	16.3 0.64	87.6 3.45	106.2 4.18	15.9 35	
QVVTU16V212S	2 3/4 in.																		
QVVTU16V070S	70 mm																		
QVVTU16V215S	2 15/16 in.																		
QVVTU16V300S	3 in.	22219	92.2 3.63	25.4 1.00	193.8 7.63	173.0 6.81	46.0 1.81	49.3 1.94	124.0 4.88	257.0 10.12	99.6 3.92	158.8 6.25	46.0 1.81	0.5 0.02	18.0 0.71	99.1 3.90	117.6 4.63	20.0 44	
QVVTU16V075S	75 mm																		
QVVTU19V303S	3 3/16 in.																		
QVVTU19V304S	3 1/4 in.																		
QVVTU19V080S	80 mm	22222	104.9 4.13	28.7 1.13	239.8 9.44	219.2 8.63	54.1 2.13	50.8 2.00	143.0 5.63	296.9 11.69	111.3 4.21	177.8 7.00	52.3 2.06	1.5 0.32	18.8 0.55	110.0 4.13	130.3 4.99	26.3 58	
QVVTU19V085S	85 mm																		
QVVTU19V307S	3 7/16 in.																		
QVVTU19V308S	3 1/2 in.																		
QVVTU19V090S	90 mm																		
QVVTU22V311S	3 1/16 in.																		
QVVTU22V312S	3 3/4 in.																		
QVVTU22V100S	100 mm																		
QVVTU22V315S	3 15/16 in.																		
QVVTU22V400S	4 in.																		

⁽¹⁾Double-nut (QVV) part number shown. Single-nut (QV) version available upon request.

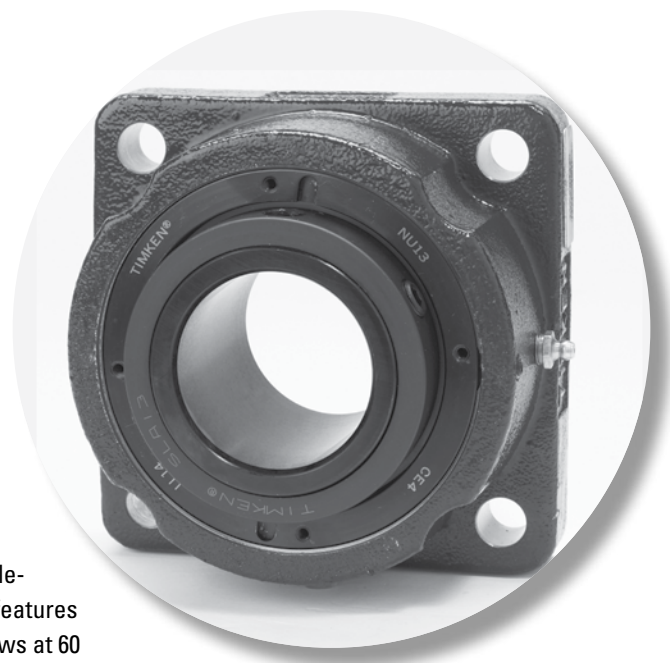

CL SERIES

Available in both single-collar (QA) and double-collar (QAA) versions, the CL bearing series features a concentric locking collar with two set screws at 60 degrees to provide maximum positive locking power with minimal run out.

The following topics are covered within this section:

Introduction	118
QAP and QAAP Stainless Steel Two-Bolt Pillow Blocks	119
QAPL and QAAPL Two-Bolt Pillow Blocks	121
QASN and QAASN SN-Style Two-Bolt Pillow Blocks	123
QAAPXT 5000 Series Two-Bolt Pillow Blocks	125
QAPF and QAAPF Four-Bolt Pillow Blocks	126
QAPR and QAAPR Four-Bolt Pillow Blocks	128
QAAPX 5000 Series Four-Bolt Pillow Blocks	129
QAC and QAAC Piloted Flange Cartridges	130
QACW and QAACW Piloted Flange Cartridges	132
QAF and QAAF Square Flange Blocks	134
QAFI and QAAFI Square Flange Blocks	136
QAAF5 5000 Series Flange Blocks	138
QAFY and QAAFY Round Flange Blocks	139
QAMC and QAAMC Cartridge Blocks	141
QATU and QAATU Take-Up Blocks	143
QATP and QAATP Top Pull Take-Up Blocks	145
QAMH and QAAMH Hanger Blocks	147

CL SERIES

Fig. 47. CL series single-collar (QA) insert available up to 100 mm (4 in.).



Fig. 48. CL series double-collar (QAA) insert for size ranges 50 mm – 130 mm (1 15/16 in. – 5 in.).

YOU HAVE CHOICES

For the CL series, you can select either single-collar or double-collar versions and choose from many seal configurations and housing styles, which are shown on page 15.

HOUSINGS

- Two-bolt pillow blocks
- Four-bolt pillow blocks
- Flange blocks
- Piloted flange cartridges
- Take-up blocks
- Cartridge blocks
- Hanger blocks

SEALS

- Labyrinth: DuPont™ Teflon® (T)
- Triple-lip: nitrile rubber (M), urethane (O) and Viton® (N)
- Double-lip: nitrile rubber (B) and Viton (C)
- Steel and urethane closed-end covers (CS)
- Steel and urethane open-end covers (CJ) with:
 - DuPont Teflon (T)
 - Triple-lip seal (DR)
 - V-ring seal (VR)
- Piloted flange cartridge backing plates (HSY) with:
 - Triple-lip seal (DR)
- Flange block backing plates (UFP)
 - V-ring (VR)

QAP AND QAAP STAINLESS STEEL TWO-BOLT PILLOW BLOCKS

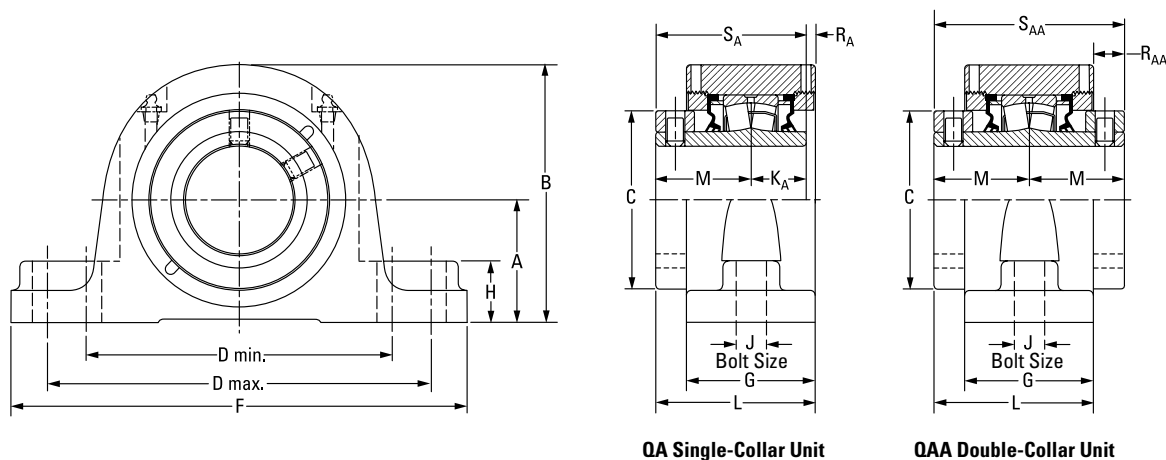

OA Single-Collar Unit

QAA Double-Collar Unit

Bearing Part No. ⁽¹⁾⁽²⁾	Shaft Dia.	Bearing No.	A	B	C	D min.	D max.	F	G	H	J	K _A	L	M	R _A	R _{AA}	S _A	S _{AA}	Wt.
			mm in.	mm in.	mm in.	mm in.	mm in.	mm in.	mm in.	mm in.	mm in.	mm in.	mm in.	mm in.	mm in.	mm in.	mm in.	mm in.	mm in.
QAP08A035SOSS	35 mm	22208	47.8	94.7	60.5	119.1	152.4	174.8	57.2	25.4	12	25.4	73.2	44.5	3.3	—	69.9	—	4.1
QAP08A107SOSS	1 7/16 in.		1.88	3.73	2.38	4.69	6.00	6.88	2.25	1.00	1/2	1.00	2.88	1.75	0.13	—	2.75	—	9
QAP08A108SOSS	1 1/2 in.	22208	54.1	101.1	60.5	119.1	165.1	200.2	57.2	25.4	1/2	25.4	73.2	44.5	3.3	—	69.9	—	4.1
			2.13	3.98	2.38	4.69	6.50	7.88	2.25	1.00	1/2	1.00	2.88	1.75	0.13	—	2.75	—	9
QAP09A111SOSS	1 1/16 in.	22209	54.1	104.9	66.8	144.8	165.1	200.2	60.2	31.8	12	25.4	78.0	47.8	4.8	—	73.2	—	4.5
			2.13	4.13	2.63	5.70	6.50	7.88	2.37	1.25	1/2	1.00	3.07	1.88	0.19	—	2.88	—	10
QAP09A040SOSS	40 mm	22209																	
QAP09A112SOSS	1 3/4 in.		57.2	108.0	66.8	158.8	180.8	225.6	62.0	31.8	16	25.4	78.7	47.8	5.6	—	73.2	—	4.5
			2.25	4.25	2.63	6.25	7.12	8.88	2.44	1.25	5/8	1.00	3.10	1.88	0.22	—	2.88	—	10
QAP09A045SOSS	45 mm																		
QAP10A115SOSS	1 9/16 in.	22210																	
QAAP10A115SOSS																			
QAP10A200SOSS	2 in.		57.2	122.2	73.2	152.4	181.1	225.6	62.0	31.8	16	25.4	79.0	47.5	6.1	17.0	72.9	95.3	5.9
QAAP10A200SOSS			2.25	4.81	2.88	6.00	7.13	8.88	2.44	1.25	5/8	1.00	3.11	1.87	0.24	0.67	2.87	3.75	13
QAP10A050SOSS	50 mm																		
QAAP10A050SOSS																			
QAP11A203SOSS	2 3/16 in.	22211																	
QAAP11A203SOSS																			
QAP11A204SOSS	2 1/4 in.		63.5	133.4	82.6	165.1	200.2	244.6	66.8	31.8	16	28.7	84.3	50.8	4.8	17.5	79.5	101.6	7.7
QAAP11A204SOSS			2.50	5.25	3.25	6.50	7.88	9.63	2.63	1.25	5/8	1.13	3.32	2.00	0.19	0.69	3.13	4.00	17
QAP11A055SOSS	55 mm																		
QAAP11A055SOSS																			
QAP13A060SOSS	60 mm	22213																	
QAAP13A060SOSS																			
QAP13A207SOSS	2 7/16 in.		69.9	147.3	96.8	174.8	219.2	260.4	73.7	35.1	16	31.5	91.4	54.6	5.3	17.8	86.1	109.2	10.0
QAAP13A207SOSS			2.75	5.80	3.81	6.88	8.63	10.25	2.90	1.38	5/8	1.24	3.60	2.15	0.21	0.70	3.39	4.30	22
QAP13A208SOSS	2 1/2 in.																		
QAAP13A208SOSS																			
QAP13A065SOSS	65 mm																		
QAAP13A065SOSS																			

⁽¹⁾Bearing part numbers use QA to designate single-collar units (use S_A and R_A dimensions) and QAA to designate double-collar units (use S_{AA} and R_{AA} dimensions).

⁽²⁾Part number shown with 'O' seals – additional seals available upon request.

Continued on next page.

QAP AND QAAP STAINLESS STEEL TWO-BOLT PILLOW BLOCKS – continued

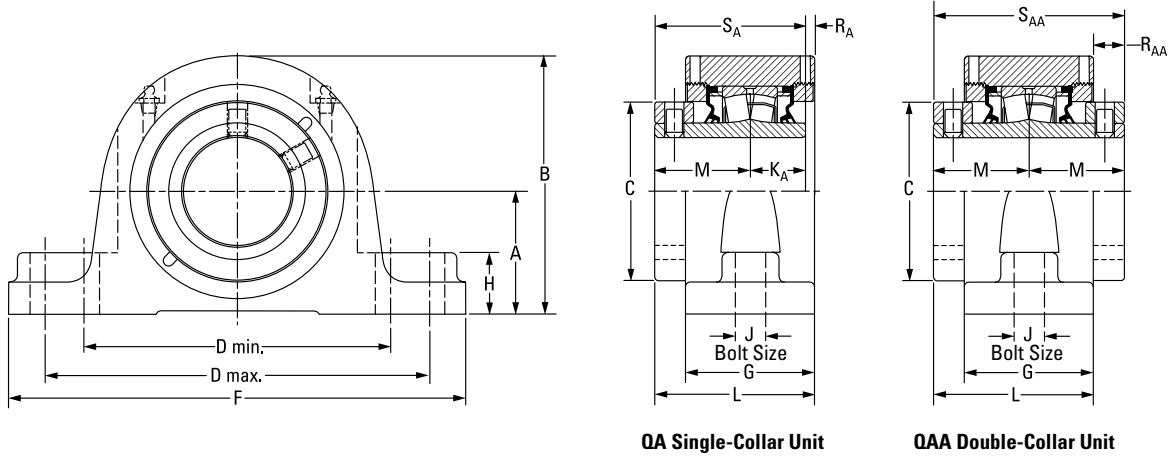

QA Single-Collar Unit

QAA Double-Collar Unit

Continued from previous page.

Bearing Part No. ⁽¹⁾⁽²⁾	Shaft Dia.	Bearing No.	A	B	C	D min.	D max.	F	G	H	J	K _A	L	M	R _A	R _{AA}	S _A	S _{AA}	Wt.
			mm in.	mm in.	mm in.	mm in.	mm in.	mm in.	mm in.	mm in.	mm in.	mm in.	mm in.	mm in.	mm in.	mm in.	mm in.	mm in.	mm in.
QAP15A211SOSS QAAP15A211SOSS	2 1/16 in.	22215	79.5 3.13	164.3 6.47	109.0 4.29	200.2 7.88	244.6 9.63	295.4 11.63	76.2 3.00	35.1 1.38	20 3/4	31.8 1.25	98.3 3.87	60.2 2.37	6.4 0.25	22.1 0.87	91.9 3.62	120.4 4.74	12.7 28
QAP15A212SOSS QAAP15A212SOSS	2 3/4 in.																		
QAP15A070SOSS QAAP15A070SOSS	70 mm																		
QAP15A215SOSS QAAP15A215SOSS	2 15/16 in.																		
QAP15A300SOSS QAAP15A300SOSS	3 in.																		
QAP15A075SOSS QAAP15A075SOSS	75 mm																		
QAP18A303SOSS QAAP18A303SOSS	3 3/16 in.	22218	95.3 3.75	195.3 7.69	130.3 5.13	238.3 9.38	285.8 11.25	342.9 13.50	86.6 3.41	47.8 1.88	24 7/8	36.6 1.44	109.2 4.30	65.8 2.59	6.9 0.27	22.6 0.89	102.4 4.03	131.6 5.18	20.4 45
QAP18A304SOSS QAAP18A304SOSS	3 1/4 in.																		
QAP18A080SOSS QAAP18A080SOSS	80 mm																		
QAP18A085SOSS QAAP18A085SOSS	85 mm																		
QAP18A307SOSS QAAP18A307SOSS	3 7/16 in.																		
QAP18A308SOSS QAAP18A308SOSS	3 1/2 in.																		
QAP18A090SOSS QAAP18A090SOSS	90 mm	22220	104.9 4.13	209.8 8.26	152.4 6.00	255.0 10.04	320.0 12.60	362.0 14.25	94.7 3.73	50.8 2.00	24 1	41.4 1.63	122.9 4.84	75.4 2.97	6.1 0.24	28.2 1.11	116.8 4.60	150.9 5.94	26.8 59
QAP20A315SOSS QAAP20A315SOSS	3 15/16 in.																		
QAP20A400SOSS QAAP20A400SOSS	4 in.																		
QAP20A100SOSS QAAP20A100SOSS	100 mm																		

⁽¹⁾Bearing part numbers use QA to designate single-collar units (use S_A and R_A dimensions) and QAA to designate double-collar units (use S_{AA} and R_{AA} dimensions).

⁽²⁾Part number shown with 'O' seals – additional seals available upon request.

QAPL AND QAAPL TWO-BOLT PILLOW BLOCKS

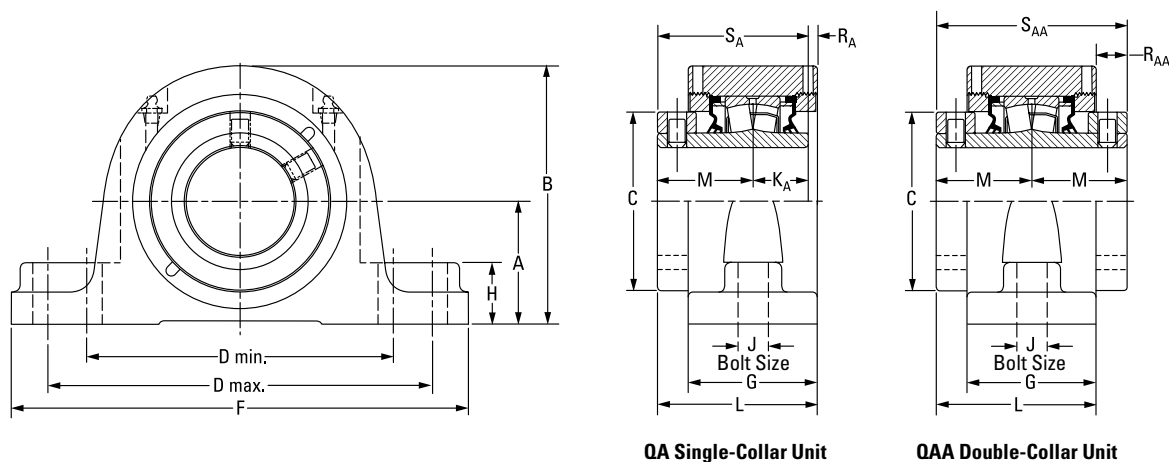

Bearing Part No. ⁽¹⁾	Shaft Dia.	Bearing No.	A	B	C	D min.	D max.	F	G	H	J	K _A	L	M	R _A	R _{AA}	S _A	S _{AA}	Wt.	
			mm in.	mm in.	mm in.	mm in.	mm in.	mm in.	mm in.	mm in.	mm in.	mm in.	mm in.	mm in.	mm in.	mm in.	mm in.	mm in.	mm in.	mm in.
QAPL08A035S	35 mm	22208	47.8 1.88	94.7 3.73	60.5 2.38	119.1 4.69	152.4 6.00	174.8 6.88	57.2 2.25	25.4 1.00	12 ½	25.4 1.00	73.2 2.88	44.5 1.75	3.3 0.13	-	69.9 2.75	-	4.1 9	
QAPL08A107S	1 7/16 in.																			
QAPL08A108S	1 ½ in.																			
QAPL09A040S	40 mm	22209	54.1 2.13	104.9 4.13	66.8 2.63	133.4 5.25	146.1 5.75	181.1 7.13	60.2 2.37	31.8 1.25	12 ½	25.4 1.00	78.0 3.07	47.8 1.88	4.8 0.19	-	73.2 2.88	-	4.5 10	
QAPL09A111S	1 1/16 in.																			
QAPL09A112S	1 ¾ in.																			
QAPL09A045S	45 mm	22210	57.2 2.25	122.2 4.81	73.2 2.88	150.6 5.93	161.5 6.36	212.9 8.38	62.0 2.44	31.8 1.25	16 5/8	25.4 1.00	79.0 3.11	47.5 1.87	6.1 0.24	17.0 0.67	72.9 2.87	95.3 3.75	5.9 13	
QAPL10A115S QAAPL10A115S	1 1/16 in.																			
QAPL10A200S QAAPL10A200S	2 in.																			
QAPL10A050S QAAPL10A050S	50 mm	22211	63.5 2.50	133.4 5.25	82.6 3.25	165.1 6.50	179.3 7.06	225.6 8.88	65.5 2.58	31.8 1.25	16 5/8	28.7 1.13	83.6 3.29	50.8 2.00	4.1 0.16	18.0 0.71	79.5 3.13	101.6 4.00	7.7 17	
QAPL11A203S QAAPL11A203S	2 3/16 in.																			
QAPL11A204S QAAPL11A204S	2 ¼ in.																			
QAPL11A055S QAAPL11A055S	55 mm	22213	69.9 2.75	147.3 5.80	96.8 3.81	173.0 6.81	189.0 7.44	235.0 9.25	73.7 2.90	35.1 1.38	16 5/8	31.5 1.24	91.4 3.60	54.6 2.15	5.3 0.21	17.8 0.70	86.1 3.39	109.2 4.30	10.0 22	
QAPL13A060S QAAPL13A060S	60 mm																			
QAPL13A207S QAAPL13A207S	2 7/16 in.																			
QAPL13A208S QAAPL13A208S	2 ½ in.																			
QAPL13A065S QAAPL13A065S	65 mm																			

⁽¹⁾Bearing part numbers use QA to designate single-collar units (use S_A and R_A dimensions) and QAA to designate double-collar units (use S_{AA} and R_{AA} dimensions).

Continued on next page.

QAPL AND QAAPL TWO-BOLT PILLOW BLOCKS – continued

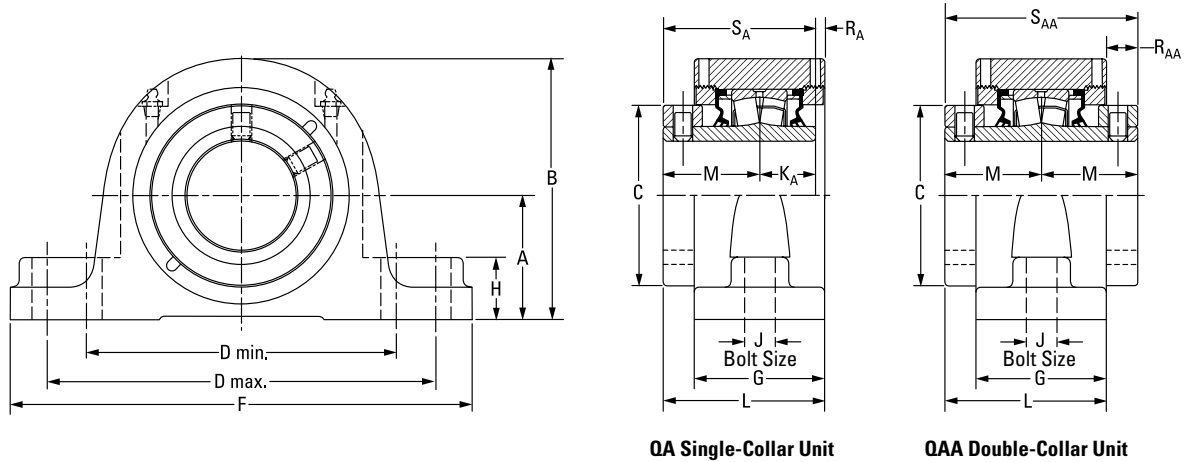

Continued from previous page.

Bearing Part No. ⁽¹⁾	Shaft Dia.	Bearing No.	A	B	C	D min.	D max.	F	G	H	J	K _A	L	M	R _A	R _{AA}	S _A	S _{AA}	Wt.	
	mm in.		mm in.	mm in.	mm in.	mm in.	mm in.	mm in.	mm in.	mm in.	mm in.	mm in.	mm in.	mm in.	mm in.	mm in.	mm in.	mm in.	mm in.	kg lbs.
QAPL15A211S QAAPL15A211S	2 1/16 in.	22215	82.6 3.25	167.4 6.59	109.0 4.29	195.6 7.70	213.4 8.40	265.2 10.44	76.2 3.00	35.1 1.38	20 3/4	31.8 1.25	98.3 3.87	60.2 2.37	6.4 0.25	22.1 0.87	91.9 3.62	120.4 4.74	12.7 28	
QAPL15A212S QAAPL15A212S	2 3/4 in.																			
QAPL15A070S QAAPL15A070S	70 mm																			
QAPL15A215S QAAPL15A215S	2 15/16 in.																			
QAPL15A300S QAAPL15A300S	3 in.																			
QAPL15A075S QAAPL15A075S	75 mm	22218	95.3 3.75	195.3 7.69	130.3 5.13	235.0 9.25	273.1 10.75	330.2 13.00	86.6 3.41	47.8 1.88	24 7/8	36.6 1.44	109.2 4.30	65.8 2.59	6.9 0.27	22.6 0.89	102.4 4.03	131.6 5.18	20.4 45	
QAPL18A303S QAAPL18A303S	3 3/16 in.																			
QAPL18A304S QAAPL18A304S	3 1/4 in.																			
QAPL18A080S QAAPL18A080S	80 mm																			
QAPL18A085S QAAPL18A085S	85 mm																			
QAPL18A307S QAAPL18A307S	3 7/16 in.	22220	108.0 4.25	212.9 8.38	152.4 6.00	255.0 10.04	320.0 12.60	362.0 14.25	94.7 3.73	54.1 2.13	24 1	41.4 1.63	122.9 4.84	75.4 2.97	6.1 0.24	28.2 1.11	116.8 4.60	150.9 5.94	26.8 59	
QAPL18A308S QAAPL18A308S	3 1/2 in.																			
QAPL18A090S QAAPL18A090S	90 mm																			
QAPL20A315S QAAPL20A315S	3 15/16 in.																			
QAPL20A400S QAAPL20A400S	4 in.																			
QAPL20A100S QAAPL20A100S	100 mm																			

⁽¹⁾Bearing part numbers use QA to designate single-collar units (use S_A and R_A dimensions) and QAA to designate double-collar units (use S_{AA} and R_{AA} dimensions).

QASN AND QAASN SN-STYLE TWO-BOLT PILLOW BLOCKS – PURE METRIC DESIGN

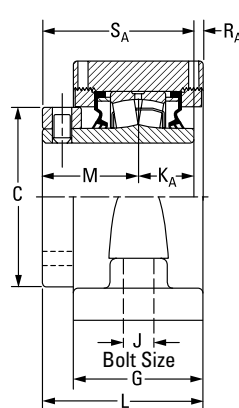
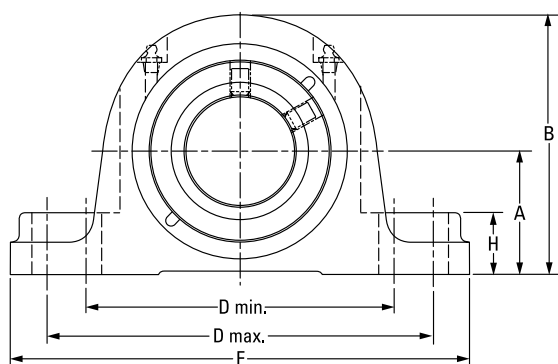

QA Single-Collar Unit

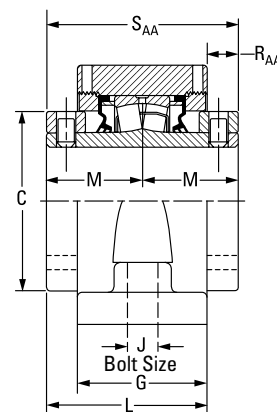

QAA Double-Collar Unit

Bearing Part No. ⁽¹⁾	Shaft Dia.	Bearing No.	A	B	C	D min.	D max.	F	G	H	J	K _A	L	M	R _A	R _{AA}	S _A	S _{AA}	Wt.
			mm in.	mm in.	mm in.	mm in.	mm in.	mm in.	mm in.	mm in.	mm in.	mm in.	mm in.	mm in.	mm in.	mm in.	mm in.	mm in.	mm in.
QASN08A035S	35 mm	22208	60	111	60.5	159	175	205	62	35	12	25	75	44	5	-	70	-	10.5
QASN08A107S	1 7/16 in.		2.36	4.37	2.38	6.26	6.89	8.07	2.44	1.38	1/2	1.00	2.95	1.75	0.20	-	2.75	-	23
QASN08A108S	1 1/2 in.																		
QASN09A040S	40 mm	22209	60	111	66.8	159	175	205	62	35	12	25	79	48	6	-	73	-	10.5
QASN09A111S	1 11/16 in.		2.36	4.37	2.63	6.26	6.89	8.07	2.44	1.38	1/2	1.00	3.10	1.88	0.22	-	2.88	-	23
QASN09A112S	1 3/4 in.																		
QASN09A045S	45 mm	22210	60	111	66.8	159	175	205	62	35	12	25	79	48	6	-	73	-	10.5
QASN10A115S	1 15/16 in.		2.36	4.37	2.63	6.26	6.89	8.07	2.44	1.38	1/2	1.00	3.10	1.88	0.22	-	2.88	-	23
QAASN10A115S																			
QASN10A200S	50 mm	22211	70	136	73	183	216	254	68	25	16	25.4	82	48	9	14	73	95	12.7
QAASN10A200S	2 in.		2.76	5.35	2.87	7.20	8.50	10.00	2.68	0.98	5/8	1.00	3.23	1.87	0.35	0.55	2.87	3.75	28
QASN10A050S	50 mm																		
QAASN10A050S																			
QASN11A203S	55 mm	22213	80	157	96.8	196	235	275	74	35	16	31	92	55	6	18	86	110	15.9
QAASN11A204S	2 3/16 in.		2.76	5.55	3.27	7.20	8.50	10.00	2.68	0.98	5/8	1.14	3.35	2.01	0.20	0.67	3.15	4.02	29
QASN11A204S	2 1/4 in.																		
QAASN11A204S																			
QASN11A055S	60 mm	22215	95	183	109.0	241	279	316	76	34	20	32	98	60	6	22	92	120	20.9
QAASN11A055S	2 3/8 in.		3.15	6.18	3.81	7.72	9.25	10.83	2.91	1.38	5/8	1.22	3.62	2.17	0.24	0.71	3.39	4.33	35
QASN13A060S	60 mm																		
QAASN13A060S																			
QASN13A207S	65 mm	22215	95	183	109.0	241	279	316	76	34	20	32	98	60	6	22	92	120	20.9
QAASN13A207S	2 7/16 in.		3.15	6.18	3.81	7.72	9.25	10.83	2.91	1.38	5/8	1.22	3.62	2.17	0.24	0.71	3.39	4.33	35
QASN13A208S	2 1/2 in.																		
QAASN13A208S																			
QASN13A065S	70 mm	22215	95	183	109.0	241	279	316	76	34	20	32	98	60	6	22	92	120	20.9
QAASN13A065S	2 7/8 in.		3.15	6.18	3.81	7.72	9.25	10.83	2.91	1.38	5/8	1.22	3.62	2.17	0.24	0.71	3.39	4.33	35
QASN15A211S	70 mm																		
QAASN15A211S																			
QASN15A212S	75 mm	22215	95	183	109.0	241	279	316	76	34	20	32	98	60	6	22	92	120	20.9
QAASN15A212S	2 3/4 in.		3.15	6.18	3.81	7.72	9.25	10.83	2.91	1.38	5/8	1.22	3.62	2.17	0.24	0.71	3.39	4.33	35
QASN15A070S	70 mm																		
QAASN15A070S																			
QASN15A215S	75 mm	22215	95	183	109.0	241	279	316	76	34	20	32	98	60	6	22	92	120	20.9
QAASN15A215S	2 15/16 in.		3.15	6.18	3.81	7.72	9.25	10.83	2.91	1.38	5/8	1.22	3.62	2.17	0.24	0.71	3.39	4.33	35
QASN15A300S	3 in.																		
QAASN15A300S																			
QASN15A075S	75 mm	22215	95	183	109.0	241	279	316	76	34	20	32	98	60	6	22	92	120	20.9
QAASN15A075S	3 in.		3.15	6.18	3.81	7.72	9.25	10.83	2.91	1.38	5/8	1.22	3.62	2.17	0.24	0.71	3.39	4.33	35

⁽¹⁾Bearing part numbers use QA to designate single-collar units (use S_A and R_A dimensions) and QAA to designate double-collar units (use S_{AA} and R_{AA} dimensions).

Continued on next page.

QASN AND QAASN SN-STYLE TWO-BOLT PILLOW BLOCKS – PURE METRIC DESIGN – continued

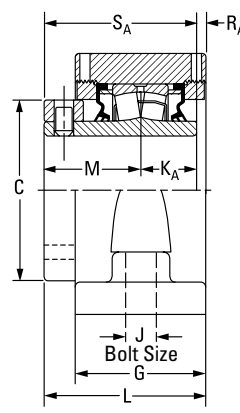
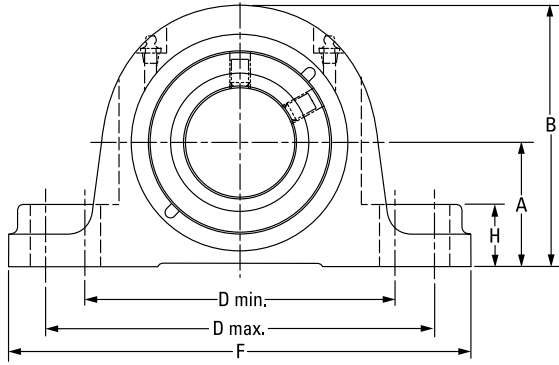

QA Single-Collar Unit

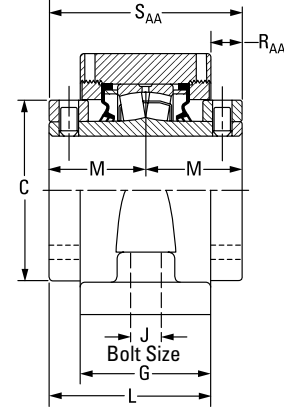

QAA Double-Collar Unit

Continued from previous page.

Bearing Part No. ⁽¹⁾	Shaft Dia.	Bearing No.	A	B	C	D min.	D max.	F	G	H	J	K _A	L	M	R _A	R _{AA}	S _A	S _{AA}	Wt.
			mm in.	mm in.	mm in.	mm in.	mm in.	mm in.	mm in.	mm in.	mm in.	mm in.	mm in.	mm in.	mm in.	mm in.	mm in.	mm in.	mm in.
QASN18A303S QAASN18A303S	3 3/16 in.	22218	100 3.94	200 7.87	130 5.12	279 10.98	292 11.50	345 13.58	86 3.39	39 1.54	20 3/4	37 1.46	109 4.29	66 2.60	6 0.24	23 0.91	102 4.02	132 5.20	25.5 56
QASN18A304S QAASN18A304S	3 1/4 in.																		
QASN18A080S QAASN18A080S	80 mm																		
QASN18A085S QAASN18A085S	85 mm	22218	112 4.41	212 8.35	130 5.12	279 10.98	292 11.50	345 13.58	86 3.39	39 1.54	20 3/4	37 1.46	109 4.29	66 2.60	6 0.24	23 0.91	102 4.02	132 5.20	25.5 56
QASN18A307S QAASN18A307S	3 7/16 in.	22218	112 4.41	212 8.35	130 5.12	290 11.42	327 12.87	380 14.96	86 3.39	39 1.54	24 7/8	37 1.46	109 4.29	66 2.60	6 0.24	23 0.91	102 4.02	132 5.20	25.5 56
QASN18A308S QAASN18A308S	3 1/2 in.																		
QASN18A090S QAASN18A090S	90 mm																		
QASN20A315S QAASN20A315S	3 15/16 in.	22220	125 4.92	241 9.49	152 5.98	319 12.56	366 14.41	410 16.14	101 3.98	50 1.97	24 7/8	41 1.61	126 4.96	75 2.95	10 0.39	25 0.98	117 4.61	150 5.91	35.9 79
QASN20A400S QAASN20A400S	4 in.																		
QASN20A100S QAASN20A100S	100 mm																		
QAASN22A110S	110 mm	22222	140 5.51	255 10.04	160 6.30	332 13.07	365 14.37	410 16.14	105 4.13	39 1.54	24 7/8	-	133 5.24	80 3.15	-	28 1.10	-	160 6.30	35.9 79
QAASN22A407S	4 7/16 in.	22222	150 5.91	265 10.43	160 6.30	367 14.45	400 15.75	445 17.52	105 4.13	49 1.93	24 7/8	-	133 5.24	80 3.15	-	28 1.10	-	160 6.30	40.0 88
QAASN22A408S	4 1/2 in.																		
QAASN22A115S	115 mm																		
QAASN26A125S	125 mm	22226	150 5.91	282 11.10	175 6.89	402 15.83	435 17.13	500 19.69	113 4.45	49 1.93	30 1 1/4	-	151 5.94	94 3.70	-	38 1.50	-	188 7.40	40.0 88
QAASN26A415S	4 15/16 in.																		
QAASN26A500S	5 in.																		
QAASN26A130S	130 mm																		

⁽¹⁾Bearing part numbers use QA to designate single-collar units (use S_A and R_A dimensions) and QAA to designate double-collar units (use S_{AA} and R_{AA} dimensions).

QAAPXT 5000 SERIES TWO-BOLT PILLOW BLOCKS

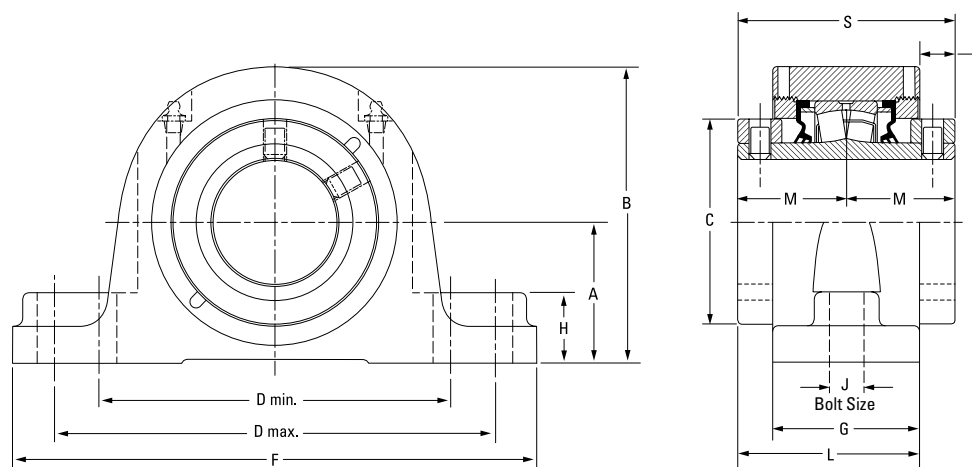

Bearing Part No.	Shaft Dia.	Bearing No.	A	B	C	D min.	D max.	F	G	H	J	L	M	R	S	Wt.
	mm in.		mm in.	mm in.	mm in.	mm in.	mm in.	mm in.	mm in.	mm in.	mm in.	mm in.	mm in.	mm in.	mm in.	kg lbs.
QAAPXT13A060S	60 mm	22213	76.2 3.00	153.7 6.05	96.8 3.81	194.6 7.66	223.0 8.78	285.8 11.25	73.7 2.90	35.1 1.38	20 3/4	91.4 3.60	54.6 2.15	17.8 0.70	109.2 4.30	10.0 22
QAAPXT13A207S	2 7/16 in.															
QAAPXT13A208S	2 1/2 in.															
QAAPXT13A065S	65 mm															
QAAPXT15A211S	2 11/16 in.	22215	88.9 3.50	173.7 6.84	109.0 4.29	230.1 9.06	265.2 10.44	330.2 13.00	75.7 2.98	35.1 1.38	24 7/8	98.0 3.86	60.2 2.37	22.4 0.88	120.4 4.74	12.7 28
QAAPXT15A212S	2 3/4 in.															
QAAPXT15A070S	70 mm															
QAAPXT15A215S	2 15/16 in.															
QAAPXT15A300S	3 in.															
QAAPXT15A075S	75 mm															

QAPF AND QAAPF FOUR-BOLT PILLOW BLOCKS

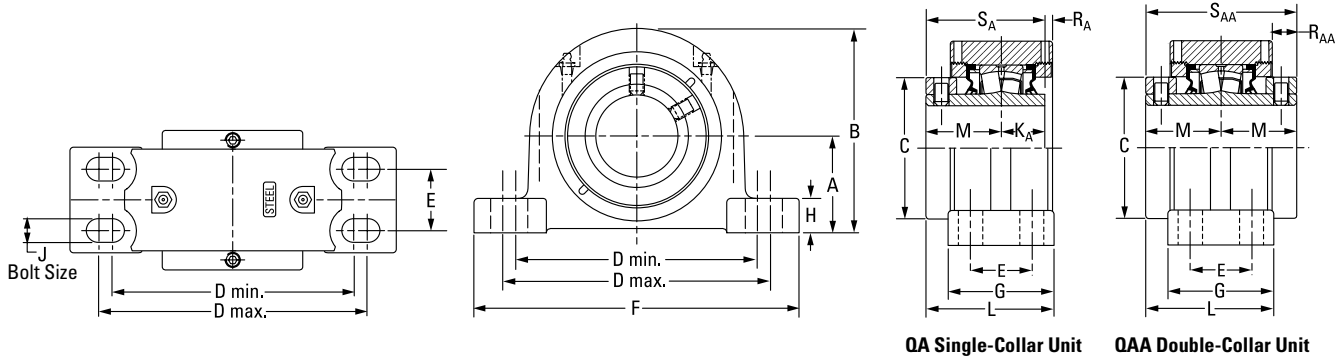

Bearing Part No. ⁽¹⁾	Shaft Dia.	Bearing No.	A	B	C	D min.	D max.	E	F	G	H	J	K _A	L	M	R _A	R _{AA}	S _A	S _{AA}	Wt.	
	mm in.		mm in.	mm in.	mm in.	mm in.	mm in.	mm in.	mm in.	mm in.	mm in.	mm in.	mm in.	mm in.	mm in.	mm in.	mm in.	mm in.	mm in.	mm in.	kg lbs.
QAPF13A060S QAAPF13A060S	60 mm	22213	69.9 2.75	147.3 5.80	96.8 3.81	174.8 6.88	193.8 7.63	44.5 1.75	235.0 9.25	76.2 3.00	24.9 0.98	16 5/8	31.5 1.24	92.7 3.65	54.6 2.15	5.3 0.21	17.8 0.70	86.1 3.39	109.2 4.30	9.1 20	
QAPF13A207S QAAPF13A207S	2 7/8 in.																				
QAPF13A208S QAAPF13A208S	2 1/2 in.																				
QAPF13A065S QAAPF13A065S	65 mm																				
QAPF15A211S QAAPF15A211S	2 11/16 in.	22215	82.6 3.25	167.6 6.60	109.0 4.29	193.0 7.60	231.1 9.10	47.8 1.88	265.2 10.44	79.5 3.13	32.8 1.29	16 5/8	31.8 1.25	100.1 3.94	60.2 2.37	6.1 0.24	22.4 0.88	91.9 3.62	120.4 4.74	12.2 27	
QAPF15A212S QAAPF15A212S	2 3/4 in.																				
QAPF15A070S QAAPF15A070S	70 mm																				
QAPF15A215S QAAPF15A215S	2 15/16 in.																				
QAPF15A300S QAAPF15A300S	3 in.	22218	95.3 3.75	195.3 7.69	130.3 5.13	225.6 8.88	276.4 10.88	50.8 2.00	312.4 12.30	95.3 3.75	39.6 1.56	20 3/4	36.6 1.44	113.5 4.47	65.8 2.59	7.9 0.31	21.3 0.84	102.4 4.03	131.6 5.18	22.2 49	
QAPF15A075S QAAPF15A075S	75 mm																				
QAPF18A303S QAAPF18A303S	3 3/8 in.																				
QAPF18A304S QAAPF18A304S	3 1/4 in.																				
QAPF18A080S QAAPF18A080S	80 mm																				
QAPF18A085S QAAPF18A085S	85 mm																				
QAPF18A307S QAAPF18A307S	3 7/8 in.																				
QAPF18A308S QAAPF18A308S	3 1/2 in.																				
QAPF18A090S QAAPF18A090S	90 mm																				

⁽¹⁾Bearing part numbers use QA to designate single-collar units (use S_A and R_A dimensions) and QAA to designate double-collar units (use S_{AA} and R_{AA} dimensions).

Continued on next page.

QAPF AND QAAPF FOUR-BOLT PILLOW BLOCKS

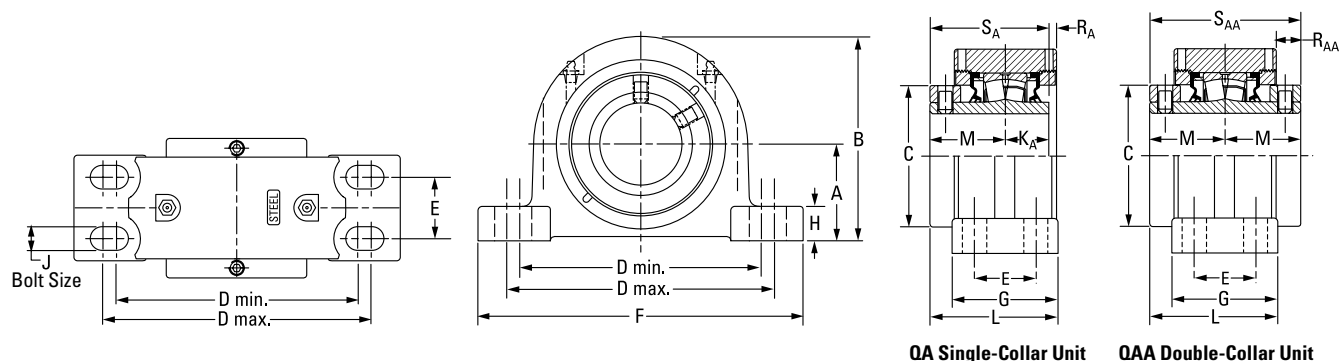

Continued from previous page.

Bearing Part No. ⁽¹⁾	Shaft Dia.	Bearing No.	A	B	C	D min.	D max.	E	F	G	H	J	K _A	L	M	R _A	R _{AA}	S _A	S _{AA}	Wt.
			mm in.	mm in.	mm in.	mm in.	mm in.	mm in.	mm in.	mm in.	mm in.	mm in.	mm in.	mm in.	mm in.	mm in.	mm in.	mm in.	mm in.	mm in.
QAPF20A315S QAAPF20A315S	3 15/16 in.	22220	108.0	223.0	152.4	276.4	339.9	57.2	378.0	109.5	35.6	20	41.4	130.3	75.4	8.9	25.1	116.6	150.9	30.4
QAPF20A400S QAAPF20A400S	4 in.		4.25	8.78	6.00	10.88	13.38	2.25	14.88	4.31	1.40	3/4	1.63	5.13	2.97	0.35	0.99	4.59	5.94	67
QAPF20A100S QAAPF20A100S	100 mm																			
QAAPF22A110S	110 mm	22222	120.7	233.4	160.0	301.8	368.3	63.5	409.7	120.7	40.1	20	-	140.0	79.5	-	28.7	-	158.8	37.2
QAAPF22A407S	4 7/16 in.		4.75	9.19	6.30	11.88	14.50	2.50	16.13	4.75	1.58	3/4	-	5.51	3.13	-	1.13	-	6.25	82
QAAPF22A408S	4 1/2 in.																			
QAAPF22A115S	115 mm	22226	139.7	279.7	175.0	349.3	403.4	69.9	444.5	128.0	39.1	24	-	158.5	94.5	-	36.8	-	189.0	60.8
QAAPF26A125S	125 mm		5.50	11.01	6.89	13.75	15.88	2.75	17.50	5.04	1.54	7/8	-	6.24	3.72	-	1.45	-	7.44	134
QAAPF26A415S	4 15/16 in.																			
QAAPF26A500S	5 in.																			
QAAPF26A130S	130 mm																			

⁽¹⁾Bearing part numbers use QA to designate single-collar units (use S_A and R_A dimensions) and QAA to designate double-collar units (use S_{AA} and R_{AA} dimensions).

QAPR AND QAAPR FOUR-BOLT PILLOW BLOCKS

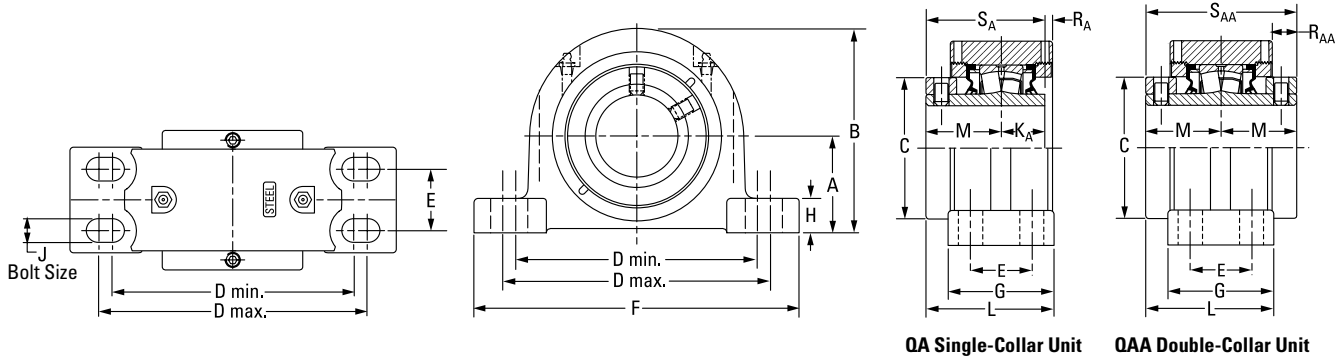

Bearing Part No. ⁽¹⁾	Shaft Dia.	Bearing No.	A	B	C	D min.	D max.	E	F	G	H	J	K _A	L	M	R _A	R _{AA}	S _A	S _{AA}	Wt.	
			mm in.	mm in.	mm in.	mm in.	mm in.	mm in.	mm in.	mm in.	mm in.	mm in.	mm in.	mm in.	mm in.	mm in.	mm in.	mm in.	mm in.	mm in.	mm in.
QAPR13A060S QAAPR13A060S	60 mm	22213	69.9 2.75	147.3 5.80	96.8 3.81	181.1 7.13	222.3 8.75	47.8 1.88	260.4 10.25	82.6 3.25	24.9 0.98	16 5/8	31.5 1.24	95.8 3.77	54.6 2.15	5.3 0.21	17.8 0.70	86.1 3.39	109.2 4.30	9.1 20	
QAPR13A207S QAAPR13A207S	2 7/8 in.																				
QAPR13A208S QAAPR13A208S	2 1/2 in.																				
QAPR13A065S QAAPR13A065S	65 mm																				
QAPR15A211S QAAPR15A211S	2 11/16 in.	22215	79.5 3.13	164.3 6.47	109.0 4.29	203.2 8.00	243.8 9.60	54.1 2.13	275.1 10.83	85.9 3.38	29.5 1.16	16 5/8	31.8 1.25	102.1 4.02	60.2 2.37	6.1 0.24	22.4 0.88	91.9 3.62	120.4 4.74	12.2 27	
QAPR15A212S QAAPR15A212S	2 3/4 in.																				
QAPR15A070S QAAPR15A070S	70 mm																				
QAPR15A215S QAAPR15A215S	2 15/16 in.																				
QAPR15A300S QAAPR15A300S	3 in.	22218	95.3 3.75	195.3 7.69	130.3 5.13	235.0 9.25	285.8 11.25	60.5 2.38	346.2 13.63	95.3 3.75	39.6 1.56	20 3/4	36.6 1.44	113.5 4.47	65.8 2.59	7.9 0.31	21.3 0.84	102.4 4.03	131.6 5.18	22.2 49	
QAPR15A075S QAAPR15A075S	75 mm																				
QAPR18A303S QAAPR18A303S	3 3/16 in.																				
QAPR18A304S QAAPR18A304S	3 1/4 in.																				
QAPR18A080S QAAPR18A080S	80 mm	22218	95.3 3.75	195.3 7.69	130.3 5.13	235.0 9.25	285.8 11.25	60.5 2.38	346.2 13.63	95.3 3.75	39.6 1.56	20 3/4	36.6 1.44	113.5 4.47	65.8 2.59	7.9 0.31	21.3 0.84	102.4 4.03	131.6 5.18	22.2 49	
QAPR18A085S QAAPR18A085S	85 mm																				
QAPR18A307S QAAPR18A307S	3 7/16 in.																				
QAPR18A308S QAAPR18A308S	3 1/2 in.																				
QAPR18A090S QAAPR18A090S	90 mm																				

⁽¹⁾Bearing part numbers use QA to designate single-collar units (use S_A and R_A dimensions) and QAA to designate double-collar units (use S_{AA} and R_{AA} dimensions).

QAAPX 5000 SERIES FOUR-BOLT PILLOW BLOCKS

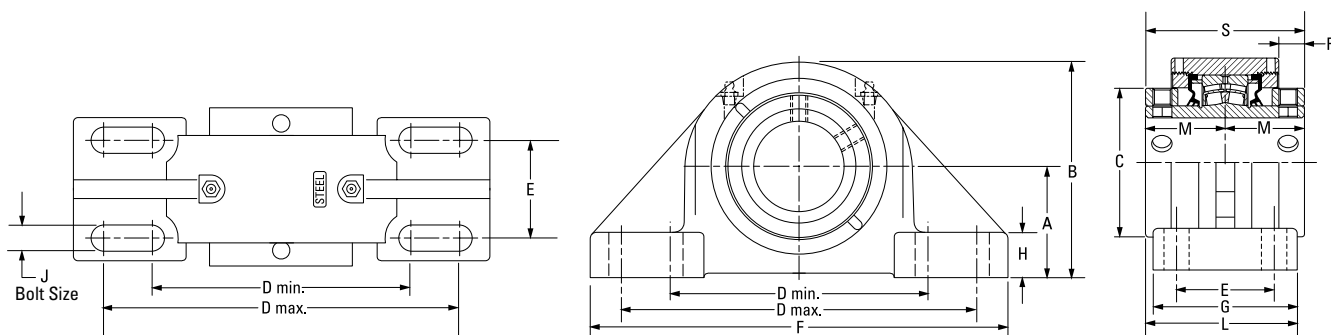

Bearing Part No. ⁽¹⁾	Shaft Dia.	Bearing No.	A	B	C	D min.	D max.	E	F	G	H	J	L	M	R	S	Wt.
			mm in.	mm in.	mm in.	mm in.	mm in.	mm in.	mm in.	mm in.	mm in.	mm in.	mm in.	mm in.	mm in.	mm in.	mm in.
QAAPX13A060S	60 mm	22213	76.2 3.00	153.7 6.05	96.8 3.81	176.3 6.94	242.8 9.56	66.8 2.63	285.8 11.25	98.6 3.88	31.0 1.22	16 %	103.9 4.09	54.6 2.15	17.8 0.70	109.2 4.30	13.2 29
QAAPX13A207S	2 7/16 in.																
QAAPX13A208S	2 1/2 in.																
QAAPX13A065S	65 mm																
QAAPX15A211S	2 11/16 in.	22215	88.9 3.50	173.5 6.83	109.0 4.29	230.1 9.06	265.2 10.44	69.9 2.75	330.2 13.00	108.0 4.25	39.1 1.54	20 3/4	114.3 4.50	60.2 2.37	21.3 0.84	120.4 4.74	20.4 45
QAAPX15A212S	2 3/4 in.																
QAAPX15A070S	70 mm																
QAAPX15A215S	2 15/16 in.																
QAAPX15A300S	3 in.	22218	101.6 4.00	201.2 7.92	130.3 5.13	274.6 10.81	309.6 12.19	76.2 3.00	381.0 15.00	120.7 4.75	38.1 1.50	20 3/4	126.2 4.97	65.8 2.59	21.3 0.84	131.6 5.18	29.0 64
QAAPX15A075S	75 mm																
QAAPX18A303S	3 3/16 in.																
QAAPX18A304S	3 1/4 in.																
QAAPX18A080S	80 mm	22220	127.0 5.00	239.8 9.44	152.4 6.00	317.5 12.50	355.6 14.00	88.9 3.50	425.5 16.75	139.7 5.50	41.4 1.63	24 %	145.0 5.71	75.2 2.96	25.4 1.00	150.4 5.92	44.9 99
QAAPX18A085S	85 mm																
QAAPX18A307S	3 3/8 in.																
QAAPX18A308S	3 1/2 in.																
QAAPX18A090S	90 mm	22222	146.1 5.75	273.8 10.78	159.8 6.29	354.1 13.94	395.2 15.56	101.6 4.00	469.9 18.50	158.8 6.25	45.7 1.80	24 1	158.8 6.25	79.5 3.13	28.7 1.13	158.8 6.25	63.0 139
QAAPX20A315S	3 15/16 in.																
QAAPX20A400S	4 in.																
QAAPX20A100S	100 mm																
QAAPX22A110S	110 mm	22226	155.7 6.13	283.2 11.15	174.8 6.88	387.4 15.25	425.5 16.75	108.0 4.25	514.4 20.25	171.5 6.75	50.8 2.00	24.0 1 1/8	180.3 7.10	94.5 3.72	37.3 1.47	189.0 7.44	67.6 149
QAAPX22A407S	4 7/16 in.																
QAAPX22A408S	4 1/2 in.																
QAAPX22A115S	115 mm																
QAAPX26A125S	125 mm	22226	155.7 6.13	283.2 11.15	174.8 6.88	387.4 15.25	425.5 16.75	108.0 4.25	514.4 20.25	171.5 6.75	50.8 2.00	24.0 1 1/8	180.3 7.10	94.5 3.72	37.3 1.47	189.0 7.44	67.6 149
QAAPX26A415S	4 15/16 in.																
QAAPX26A500S	5 in.																
QAAPX26A130S	130 mm																

⁽¹⁾Bearing part numbers use QA to designate single-collar units (use S_A and R_A dimensions) and QAA to designate double-collar units (use S_{AA} and R_{AA} dimensions).

QAC AND QAAC PILOTED FLANGE CARTRIDGES

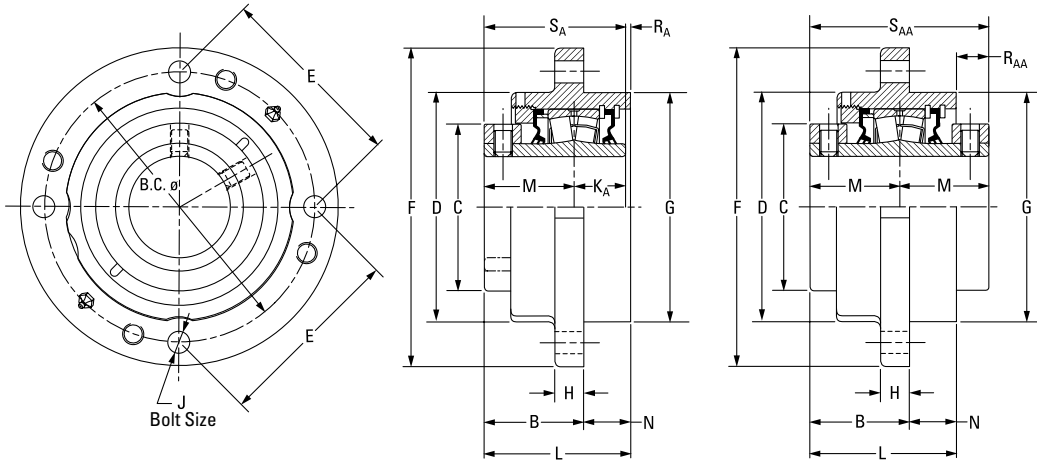

Bearing Part No. ⁽¹⁾	Shaft Dia.	Bearing No.	B FIX	B EXP	B.C.	C	D	E	F	G ⁽²⁾	H	J	K _A	L FIX	L EXP	M	N	R _A	R _{AA}	S _A	S _{AA}	Wt.	
	mm in.		mm in.	mm in.	mm in.	mm in.	mm in.	mm in.	mm in.	mm in.	mm in.	mm in.	mm in.	mm in.	mm in.	mm in.	mm in.	mm in.	mm in.	mm in.	mm in.	mm in.	kg lbs.
QAC08A035S	35 mm	22208	49.8 1.96	51.8 2.04	111.3 4.38	60.5 2.38	92.2 3.63	78.5 3.09	133.4 5.25	92.1 3.625	12.7 0.50	10 7/16	25.4 1.00	73.7 2.90	75.7 2.98	44.5 1.75	23.9 0.94	3.8 0.15	-	69.9 2.75	-	-	3.6 8
QAC08A107S	1 7/16 in.																						
QAC08A108S	1 1/2 in.																						
QAC09A040S	40 mm	22209	54.6 2.15	56.6 2.23	130.3 5.13	66.8 2.63	111.3 4.38	91.9 3.62	155.7 6.13	108.0 4.250	12.7 0.50	10 7/16	25.4 1.00	77.0 3.03	78.2 3.08	47.8 1.88	22.4 0.88	3.8 0.15	-	73.2 2.88	-	-	4.1 9
QAC09A111S	1 11/16 in.																						
QAC09A112S	1 3/4 in.																						
QAC09A045S	45 mm	22210	50.5 1.99	52.6 2.07	136.7 5.38	73.2 2.88	113.5 4.47	96.5 3.80	162.1 6.38	114.3 4.500	16.0 0.63	10 7/16	25.4 1.00	77.5 3.05	79.5 3.13	47.5 1.87	26.9 1.06	4.6 0.18	18.5 0.73	72.9 2.87	95.3 3.75	4.5 10	
QAC10A115S QAAC10A115S	1 11/16 in.																						
QAC10A200S QAAC10A200S	2 in.																						
QAC10A050S QAAC10A050S	50 mm	22211	54.4 2.14	56.4 2.22	152.4 6.00	82.6 3.25	127.0 5.00	107.7 4.24	185.4 7.30	127.0 5.000	14.7 0.58	12 1/2	28.7 1.13	83.1 3.27	85.1 3.35	50.8 2.00	28.7 1.13	3.6 0.14	18.5 0.73	79.5 3.13	101.6 4.00	5.9 13	
QAC11A203S QAAC11A203S	2 3/16 in.																						
QAC11A204S QAAC11A204S	2 1/4 in.																						
QAC11A055S QAAC11A055S	55 mm	22213	60.5 2.38	62.5 2.46	165.1 6.50	96.8 3.81	139.7 5.50	116.8 4.60	193.8 7.63	139.7 5.500	17.5 0.69	12 1/2	31.5 1.24	88.9 3.50	90.9 3.58	54.6 2.15	28.7 1.13	3.0 0.12	20.3 0.80	86.1 3.39	109.2 4.30	7.3 16	
QAC13A060S QAAC13A060S	60 mm																						
QAC13A207S QAAC13A207S	2 7/16 in.																						
QAC13A208S QAAC13A208S	2 1/2 in.	22213	60.5 2.38	62.5 2.46	165.1 6.50	96.8 3.81	139.7 5.50	116.8 4.60	193.8 7.63	139.7 5.500	17.5 0.69	12 1/2	31.5 1.24	88.9 3.50	90.9 3.58	54.6 2.15	28.7 1.13	3.0 0.12	20.3 0.80	86.1 3.39	109.2 4.30	7.3 16	
QAC13A065S QAAC13A065S	65 mm																						

⁽¹⁾Bearing part numbers use QA to designate single-collar units (use S_A and R_A dimensions) and QAA to designate double-collar units (use S_{AA} and R_{AA} dimensions).

⁽²⁾Pilot tolerance: +0/-0.051 mm (+0/-0.002 in.).

⁽³⁾Six-bolt housing.

Continued on next page.

QAC AND QAAC PILOTED FLANGE CARTRIDGES

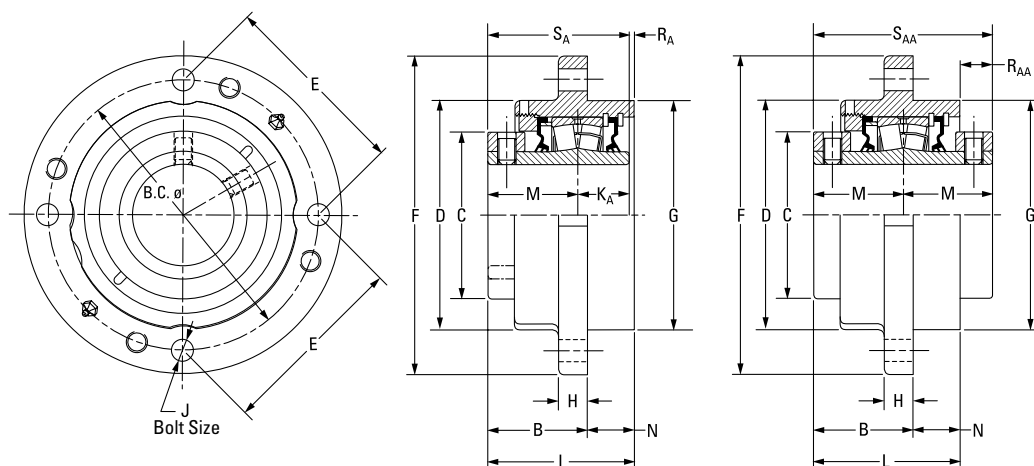

Continued from previous page.

Bearing Part No. ⁽¹⁾	Shaft Dia.	Bearing No.	B FIX	B EXP	B.C.	C	D	E	F	G ⁽²⁾	H	J	K _A	L FIX	L EXP	M	N	R _A	R _{AA}	S _A	S _{AA}	Wt.
	mm in.		mm in.	mm in.	mm in.	mm in.	mm in.	mm in.	mm in.	mm in.	mm in.	mm in.	mm in.	mm in.	mm in.	mm in.	mm in.	mm in.	mm in.	mm in.	mm in.	kg lbs.
QAC15A211S QAAC15A211S	2 1 ¹ / ₁₆ in.	22215	62.5 2.46	64.5 2.54	190.5 7.50	109.0 4.29	162.1 6.38	134.6 5.30	222.3 8.75	161.9 6.375	20.6 0.81	16 5/8	31.8 1.25	94.2 3.71	96.3 3.79	60.2 2.37	31.8 1.25	2.3 0.09	21.6 0.85	91.9 3.62	120.4 4.74	10.0 22
QAC15A212S QAAC15A212S	2 3/4 in.																					
QAC15A070S QAAC15A070S	70 mm																					
QAC15A215S QAAC15A215S	2 15/16 in.																					
QAC15A300S QAAC15A300S	3 in.																					
QAC15A075S QAAC15A075S	75 mm																					
QAC18A303S QAAC18A303S	3 3/16 in.	22218	73.2 2.88	75.2 2.96	219.2 8.63	130.3 5.13	187.5 7.38	154.9 6.10	262.6 10.34	187.3 7.375	25.4 1.00	20 3/4	36.6 1.44	106.4 4.19	108.5 4.27	65.8 2.59	33.3 1.31	4.1 0.16	25.1 0.99	102.4 4.03	131.6 5.18	14.5 32
QAC18A304S QAAC18A304S	3 1/4 in.																					
QAC18A080S QAAC18A080S	80 mm																					
QAC18A085S QAAC18A085S	85 mm																					
QAC18A307S QAAC18A307S	3 7/16 in.																					
QAC18A308S QAAC18A308S	3 1/2 in.																					
QAC18A090S QAAC18A090S	90 mm																					
QAC20A315S QAAC20A315S	3 15/16 in.	22220	72.1 2.84	74.2 2.92	238.3 9.38	152.4 6.00	206.5 8.13	168.4 6.63	276.4 10.88	206.4 8.125	25.4 1.00	20 3/4	41.4 1.63	126.0 4.96	128.0 5.04	75.4 2.97	54.1 2.13	9.4 0.37	24.9 0.98	116.6 4.59	150.9 5.94	19.5 43
QAC20A400S QAAC20A400S	4 in.																					
QAC20A100S QAAC20A100S	100 mm																					
QAAC22A110S	110 mm																					
QAAC22A407S ⁽³⁾	4 7/16 in.	22222	78.0 3.07	80.0 3.15	298.5 11.75 ⁽³⁾	160.0 6.30	254.0 10.00	149.4 5.88 ⁽³⁾	342.9 13.50	260.4 10.250	25.4 1.00	20 3/4 ⁽³⁾	-	126.2 4.97	128.3 5.05	79.5 3.13	48.3 1.90	-	32.8 1.29	-	158.8 6.25	32.7 72
QAAC22A408S ⁽³⁾	4 1/2 in.																					
QAAC22A115S ⁽³⁾	115 mm																					

⁽¹⁾Bearing part numbers use QA to designate single-collar units (use S_A and R_A dimensions) and QAA to designate double-collar units (use S_{AA} and R_{AA} dimensions).

⁽²⁾Pilot tolerance: +0/-0.051 mm (+0/-0.002 in.).

⁽³⁾Six-bolt housing.

QACW AND QAACW PILOTED FLANGE CARTRIDGES

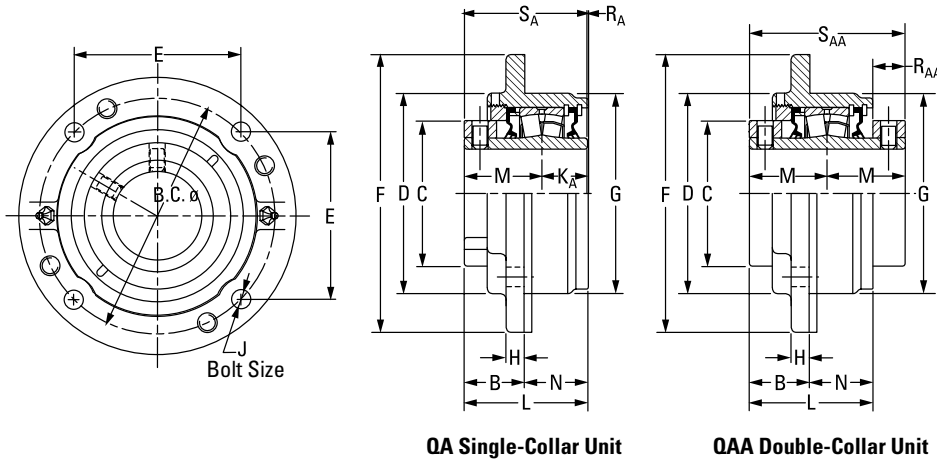

QA Single-Collar Unit

QAA Double-Collar Unit

Bearing Part No. ⁽¹⁾	Shaft Dia.	Bearing No.	B FIX	B EXP	B.C.	C	D	E	F	G ⁽²⁾	H	J	K _A	L FIX	L EXP	M	N	R _A	R _{AA}	S _A	S _{AA}	Wt.	
	mm in.		mm in.	mm in.	mm in.	mm in.	mm in.	mm in.	mm in.	mm in.	mm in.	mm in.	mm in.	mm in.	mm in.	mm in.	mm in.	mm in.	mm in.	mm in.	mm in.	mm in.	kg lbs.
QACW08A035S	35 mm	22208	38.9	40.9	111.3	60.5	92.2	78.5	133.4	92.1	12.7	10	25.4	73.7	75.7	44.5	35.1	3.8	-	69.9	-	3.6	
QACW08A107S	1 7/16 in.		1.53	1.61	4.38	2.38	3.63	3.09	5.25	3.625	0.50	7/16	1.00	2.90	2.98	1.75	1.38	0.15	-	2.75	-	8	
QACW08A108S	1 1/2 in.																						
QACW09A040S	40 mm	22209	38.9	40.1	130.3	66.8	111.3	91.9	155.7	108.0	10.2	10	25.4	77.0	78.2	47.8	38.1	4.1	-	73.2	-	4.1	
QACW09A111S	1 1/8 in.		1.53	1.58	5.13	2.63	4.38	3.62	6.13	4.250	0.40	7/16	1.00	3.03	3.08	1.88	1.5	0.16	-	2.88	-	9	
QACW09A112S	1 3/4 in.																						
QACW09A045S	45 mm	22210	35.3	37.3	136.7	73.2	113.5	96.5	162.1	114.3	9.7	10	25.4	73.4	75.4	47.5	38.1	0.5	22.6	72.9	95.3	4.5	
QACW10A115S	1 15/16 in.		1.39	1.47	5.38	2.88	4.47	3.80	6.38	4.500	0.38	7/16	1.00	2.89	2.97	1.87	1.50	0.02	0.89	2.87	3.75	10	
QAACW10A115S	2 in.																						
QACW10A050S	50 mm	22211	38.9	40.9	152.4	82.6	126.7	107.7	181.1	127.0	14.2	12	28.7	80.3	82.3	50.8	41.4	0.8	14.7	79.5	101.6	5.9	
QACW11A203S	2 3/16 in.		1.53	1.61	6.00	3.25	4.99	4.24	7.13	5.000	0.56	1/2	1.13	3.16	3.24	2.00	1.63	0.03	0.58	3.13	4.00	13	
QAACW11A203S	2 1/4 in.																						
QACW11A204S	55 mm	22213	47.2	49.3	165.1	96.8	139.7	116.8	193.8	139.7	12.7	12	31.5	90.2	92.2	54.6	42.9	4.3	19.1	86.1	109.2	7.3	
QACW13A060S	60 mm		1.86	1.94	6.50	3.81	5.50	4.60	7.63	5.500	0.50	1/2	1.24	3.55	3.63	2.15	1.69	0.17	0.75	3.39	4.30	16	
QAACW13A060S	2 7/16 in.																						
QACW13A207S	65 mm	22215	46.0	48.0	190.5	109.0	162.1	134.6	222.3	161.9	12.7	16	31.8	93.5	95.5	60.2	47.8	1.5	26.9	91.9	120.4	10.0	
QACW13A208S	2 1/2 in.		1.81	1.89	7.50	4.29	6.38	5.30	8.75	6.375	0.50	5/8	1.25	3.68	3.76	2.37	1.88	0.06	1.06	3.62	4.74	22	
QAACW13A208S	2 3/4 in.																						
QACW15A070S	70 mm	22215	46.0	48.0	190.5	109.0	162.1	134.6	222.3	161.9	12.7	16	31.8	93.5	95.5	60.2	47.8	1.5	26.9	91.9	120.4	10.0	
QACW15A215S	2 15/16 in.		1.81	1.89	7.50	4.29	6.38	5.30	8.75	6.375	0.50	5/8	1.25	3.68	3.76	2.37	1.88	0.06	1.06	3.62	4.74	22	
QAACW15A215S	3 in.																						
QACW15A300S	75 mm	22215	46.0	48.0	190.5	109.0	162.1	134.6	222.3	161.9	12.7	16	31.8	93.5	95.5	60.2	47.8	1.5	26.9	91.9	120.4	10.0	
QAACW15A300S	3 in.																						
QACW15A075S	75 mm	22215	46.0	48.0	190.5	109.0	162.1	134.6	222.3	161.9	12.7	16	31.8	93.5	95.5	60.2	47.8	1.5	26.9	91.9	120.4	10.0	
QAACW15A075S	3 in.																						

⁽¹⁾Bearing part numbers use QA to designate single-collar units (use S_A and R_A dimensions) and QAA to designate double-collar units (use S_{AA} and R_{AA} dimensions).

⁽²⁾Pilot tolerance: +0/-0.051 mm (+0/-0.002 in.).

⁽³⁾Six-bolt housing.

Continued on next page.

QACW AND QAACW PILOTED FLANGE CARTRIDGES

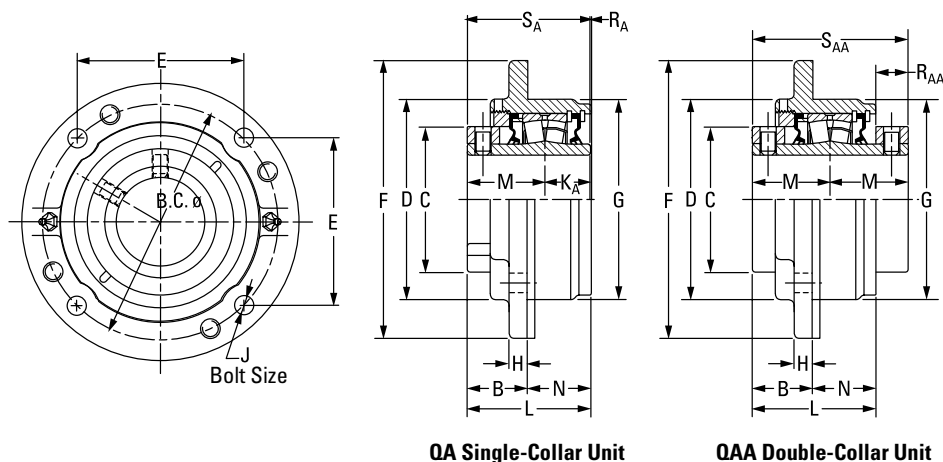

Continued from previous page.

Bearing Part No. ⁽¹⁾	Shaft Dia.	Bearing No.	B FIX	B EXP	B.C.	C	D	E	F	G ⁽²⁾	H	J	KA	L FIX	L EXP	M	N	RA	RAA	SA	SAA	Wt.																					
	mm in.		mm in.	mm in.	mm in.	mm in.	mm in.	mm in.	mm in.	mm in.	mm in.	mm in.	mm in.	mm in.	mm in.	mm in.	mm in.	mm in.	mm in.	mm in.	mm in.	mm in.	kg lbs.																				
QACW18A303S QAACW18A303S	3 3/16 in.	22218	58.2 2.29	60.2 2.37	219.2 8.63	130.3 5.13	187.5 7.38	154.9 6.10	260.4 10.25	187.3 7.375	22.4 0.88	20 3/4	36.6 1.44	105.9 4.17	108.0 4.25	65.8 2.59	47.8 1.88	3.3 0.13	21.3 0.84	102.4 4.03	131.6 5.18	14.5 32																					
QACW18A304S QAACW18A304S	3 1/4 in.																																										
QACW18A080S QAACW18A080S	80 mm																																										
QACW18A085S QAACW18A085S	85 mm																																										
QACW18A307S QAACW18A307S	3 7/16 in.																																										
QACW18A308S QAACW18A308S	3 1/2 in.																																										
QACW18A090S QAACW18A090S	90 mm																																										
QACW20A315S QAACW20A315S	3 15/16 in.																						22220	65.5 2.58	67.6 2.66	238.3 9.38	152.4 6.00	206.5 8.13	168.4 6.63	276.4 10.88	206.4 8.125	25.4 1.00	20 3/4	41.4 1.63	123.4 4.86	125.5 4.94	75.4 2.97	57.9 2.28	6.9 0.27	30.2 1.19	116.6 4.59	150.9 5.94	19.5 43
QACW20A400S QAACW20A400S	4 in.																																										
QACW20A100S QAACW20A100S	100 mm																																										
QAACW22A110S	110 mm																																										
QAACW22A407S ⁽³⁾	4 7/16 in.	22222	62.0 2.44	64.0 2.52	298.5 11.75 ⁽³⁾	160.0 6.30	254.0 10.00	149.4 5.88 ⁽³⁾	342.9 13.50	260.4 10.250	25.4 1.00	20 3/4 ⁽³⁾	-	130.0 5.12	132.1 5.20	79.5 3.13	68.3 2.69	-	28.7 1.13	-	158.8 6.25	32.7 72																					
QAACW22A408S ⁽³⁾	4 1/2 in.																																										
QAACW22A115S ⁽³⁾	115 mm																																										
QAACW26A125S ⁽³⁾	125 mm	22226	73.7 2.90	75.7 2.98	323.9 12.75 ⁽³⁾	175.0 6.89	266.7 10.50	162.1 6.38 ⁽³⁾	374.7 14.75	279.4 11.000	26.2 1.03	24 7/8 ⁽³⁾	-	153.2 6.03	155.2 6.11	94.5 3.72	78.0 3.07	-	35.8 1.41	-	189.0 7.44	46.3 102																					
QAACW26A415S ⁽³⁾	4 15/16 in.																																										
QAACW26A500S ⁽³⁾	5 in.																																										
QAACW26A130S ⁽³⁾	130 mm																																										

⁽¹⁾Bearing part numbers use QA to designate single-collar units (use SA and RA dimensions) and QAA to designate double-collar units (use SAA and RAA dimensions).

⁽²⁾Pilot tolerance: +0/-0.051 mm (+0/-0.002 in.).

⁽³⁾Six-bolt housing.

QAF AND QAAF SQUARE FLANGE BLOCKS

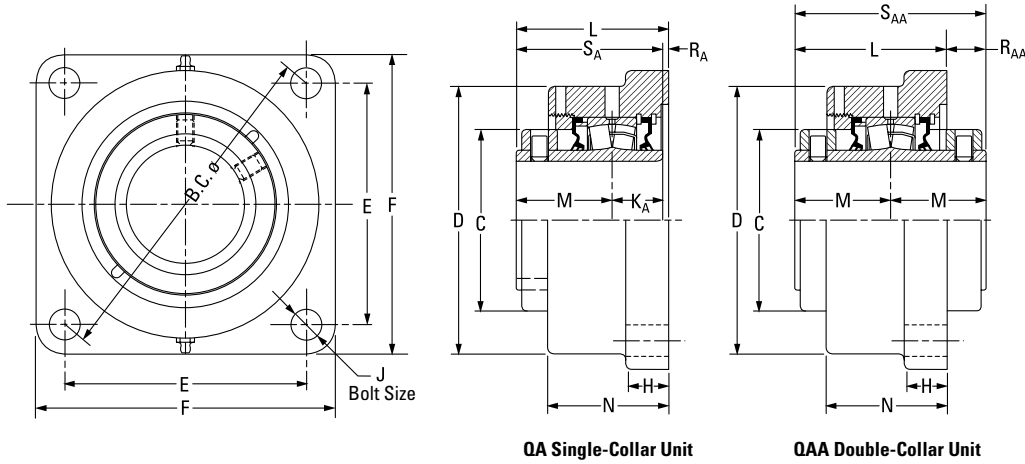

Bearing Part No. ⁽¹⁾	Shaft Dia.	Bearing No.	B.C.	C	D	E	F	H	J	KA	L FIX	L EXP	M	N	RA	RAA	SA	SAA	Wt.
	mm in.		mm in.	mm in.	mm in.	mm in.	mm in.	mm in.	mm in.	mm in.	mm in.	mm in.	mm in.	mm in.	mm in.	mm in.	mm in.	mm in.	kg lbs.
QAF08A035S	35 mm	22208	125.7	60.5	93.7	88.9	117.6	22.4	12	25.4	72.9	74.9	44.5	57.2	3.0	-	69.9	-	4.5
QAF08A107S	1 7/16 in.		4.95	2.38	3.69	3.50	4.63	0.88	1/2	1.00	2.87	2.95	1.75	2.25	0.12	-	2.75	-	10
QAF08A108S	1 1/2 in.	22208	148.3	60.5	108.0	104.9	136.7	22.4	12	25.4	73.7	75.7	44.5	59.4	3.8	-	69.9	-	4.5
			5.84	2.38	4.25	4.13	5.38	0.88	1/2	1.00	2.90	2.98	1.75	2.34	0.15	-	2.75	-	10
QAF09A040S	40 mm	22209	148.3	66.8	118.4	104.9	136.7	22.4	12	25.4	79.5	81.5	47.8	63.5	6.4	-	73.2	-	5.0
QAF09A111S	1 1/16 in.		5.84	2.63	4.66	4.13	5.38	0.88	1/2	1.00	3.13	3.21	1.88	2.50	0.25	-	2.88	-	11
QAF09A112S	1 3/4 in.	22209	157.2	66.8	118.4	111.3	143.0	22.4	12	25.4	79.5	81.5	47.8	63.5	6.4	-	73.2	-	5.0
QAF09A045S	45 mm		6.19	2.63	4.66	4.38	5.63	0.88	1/2	1.00	3.13	3.21	1.88	2.50	0.25	-	2.88	-	11
QAF10A115S	1 15/16 in.	22210	157.2	73.2	120.7	111.3	139.7	22.4	12	25.4	80.8	82.8	47.5	65.0	7.9	15.2	72.9	95.3	5.0
QAAF10A115S																			
QAF10A200S	2 in.		6.19	2.88	4.75	4.38	5.50	0.88	1/2	1.00	3.18	3.26	1.87	2.56	0.31	0.60	2.87	3.75	11
QAAF10A200S	50 mm																		
QAF10A050S	2 3/16 in.	22211	175.0	82.6	130.3	124.0	157.2	25.4	16	28.7	83.1	85.1	50.8	66.8	3.8	18.5	79.5	101.6	6.4
QAAF11A203S																			
QAF11A204S	2 1/4 in.		6.89	3.25	5.13	4.88	6.19	1.00	5/8	1.13	3.27	3.35	2.00	2.63	0.15	0.73	3.13	4.00	14
QAAF11A204S	55 mm																		
QAF11A055S	2 7/16 in.	22213	193.0	96.8	146.1	136.7	168.4	25.4	16	31.5	89.2	91.2	54.6	72.4	3.0	20.1	86.1	109.2	7.7
QAAF11A055S																			
QAF13A060S	60 mm		7.60	3.81	5.75	5.38	6.63	1.00	5/8	1.24	3.51	3.59	2.15	2.85	0.12	0.79	3.39	4.30	17
QAF13A207S	2 7/16 in.																		
QAAF13A207S	65 mm																		
QAF13A208S	2 1/2 in.																		
QAAF13A208S																			
QAF13A065S																			
QAAF13A065S																			

⁽¹⁾Bearing part numbers use QA to designate single-collar units (use SA and RA dimensions) and QAA to designate double-collar units (use SAA and RAA dimensions).

Continued on next page.

QAF AND QAAF SQUARE FLANGE BLOCKS

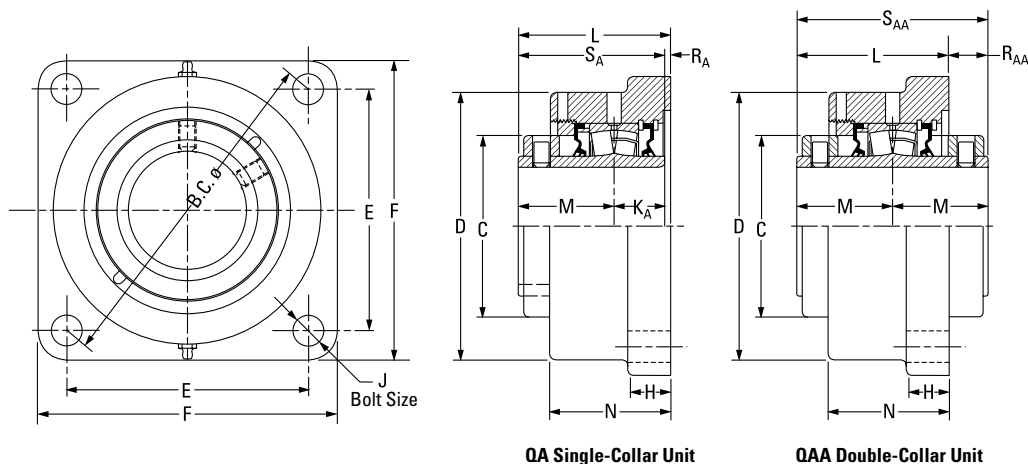

QA Single-Collar Unit

QAA Double-Collar Unit

Continued from previous page.

Bearing Part No. ⁽¹⁾	Shaft Dia.	Bearing No.	B.C.	C	D	E	F	H	J	KA	L FIX	L EXP	M	N	RA	RAA	SA	SAA	Wt.
	mm in.		mm in.	mm in.	mm in.	mm in.	mm in.	mm in.	mm in.	mm in.	mm in.	mm in.	mm in.	mm in.	mm in.	mm in.	mm in.	mm in.	kg lbs.
QAF15A211S QAAF15A211S	2 1/16 in.	22215	215.4 8.48	109.0 4.29	168.9 6.65	152.4 6.00	189.0 7.44	26.9 1.06	20 3/4	31.8 1.25	95.8 3.77	97.8 3.85	60.2 2.37	76.2 3.00	3.8 0.15	24.6 0.97	91.9 3.62	120.4 4.74	10.4 23
QAF15A212S QAAF15A212S	2 3/4 in.																		
QAF15A070S QAAF15A070S	70 mm																		
QAF15A215S QAAF15A215S	2 15/16 in.																		
QAF15A300S QAAF15A300S	3 in.																		
QAF15A075S QAAF15A075S	75 mm																		
QAF18A303S QAAF18A303S	3 3/16 in.	22218	251.7 9.91	130.3 5.13	193.8 7.63	177.8 7.00	219.2 8.63	33.3 1.31	20 3/4	36.6 1.44	107.2 4.22	109.2 4.30	65.8 2.59	84.1 3.31	4.8 0.19	24.4 0.96	102.4 4.03	131.6 5.18	15.9 35
QAF18A304S QAAF18A304S	3 1/4 in.																		
QAF18A080S QAAF18A080S	80 mm																		
QAF18A085S QAAF18A085S	85 mm																		
QAF18A307S QAAF18A307S	3 7/16 in.																		
QAF18A308S QAAF18A308S	3 1/2 in.																		
QAF18A090S QAAF18A090S	90 mm	22220	278.4 10.96	152.4 6.00	224.0 8.82	196.9 7.75	253.2 9.97	38.1 1.50	24 7/8	41.4 1.63	126.0 4.96	128.0 5.04	75.4 2.97	103.1 4.06	9.4 0.37	24.1 0.95	116.6 4.59	150.4 5.92	24.9 55
QAF20A315S QAAF20A315S	3 15/16 in.																		
QAF20A400S QAAF20A400S	4 in.																		
QAF20A100S QAAF20A100S	100 mm	22222	314.5 12.38	155.70 6.13	256.8 10.11	222.3 8.75	276.4 10.88	38.1 1.50	24 7/8	-	135.6 5.34	137.7 5.42	79.5 3.13	106.9 4.21	-	23.4 0.92	-	158.8 6.25	28.6 63
QAAF22A110S	110 mm																		
QAAF22A407S	4 7/16 in.																		
QAAF22A408S	4 1/2 in.																		
QAAF22A115S	115 mm																		

⁽¹⁾Bearing part numbers use QA to designate single-collar units (use SA and RA dimensions) and QAA to designate double-collar units (use SAA and RAA dimensions).

QAFL AND QAAFL SQUARE FLANGE BLOCKS

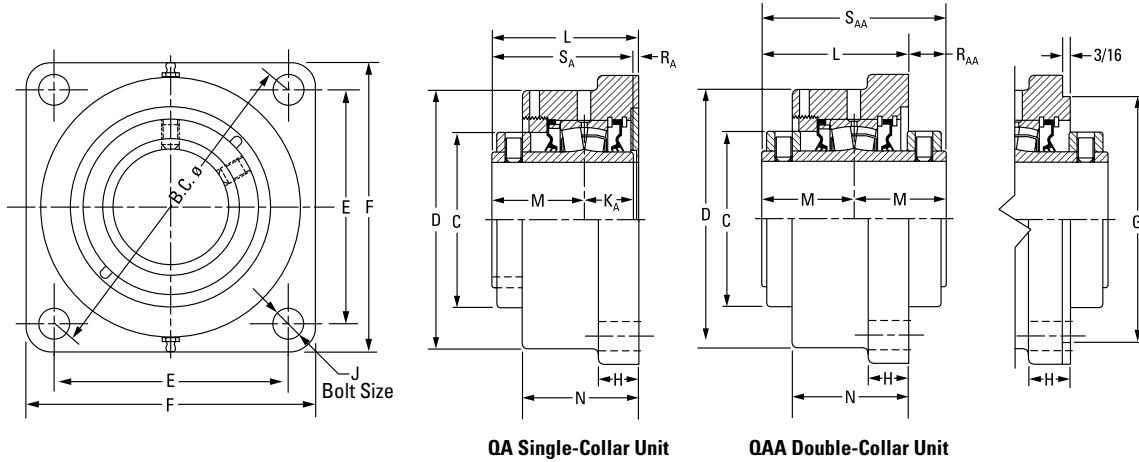

Bearing Part No. ⁽¹⁾	Shaft Dia.	Bearing No.	B.C.	C	D	E	F	G ⁽²⁾⁽³⁾⁽⁴⁾	H	J	K _A	L FIX	L EXP	M	N	R _A	R _{AA}	S _A	S _{AA}	Wt.	
	mm in.		mm in.	mm in.	mm in.	mm in.	mm in.	mm in.	mm in.	mm in.	mm in.	mm in.	mm in.	mm in.	mm in.	mm in.	mm in.	mm in.	mm in.	kg lbs.	
QAFL08A035S	35 mm	22208	127.0	60.5	93.7	89.9	117.6	N/A	22.4	12	25.4	72.9	74.9	44.5	57.2	3.0	-	69.9	-	4.5	
QAFL08A107S	1 7/16 in.		5.00	2.38	3.69	3.54	4.63		0.88	1/2	1.00	2.87	2.95	1.75	2.25	0.12		2.75		10	
QAFL08A108S	1 1/2 in.																				
QAFL09A040S	40 mm	22209	139.7	66.8	118.4	98.8	136.7	N/A	22.4	12	25.4	79.5	81.5	47.8	63.5	6.6	-	73.2	-	5.0	
QAFL09A111S	1 1/4 in.		5.50	2.63	4.66	3.89	5.38		0.88	1/2	1.00	3.13	3.21	1.88	2.50	0.26		2.88		11	
QAFL09A112S	1 3/4 in.																				
QAFL09A045S	45 mm																				
QAFL10A115S	1 1/4 in.	22210	146.1	73.2	115.3	103.4	131.8	N/A	23.1	12	25.4	80.8	82.8	47.5	62.5	7.9	15.2	72.9	95.3	5.0	
QAFL10A200S	2 in.		5.75	2.88	4.54	4.07	5.19		0.91	1/2	1.00	3.18	3.26	1.87	2.46	0.31	0.60	2.87	3.75	11	
QAFL10A050S	50 mm																				
QAFL10A050S	50 mm																				
QAFL11A203S	2 3/16 in.	22211	162.1	82.6	131.8	114.3	149.4	N/A	19.1	16	28.7	83.3	85.3	50.8	66.8	3.8	18.3	79.5	101.6	6.4	
QAFL11A204S	2 1/4 in.		6.38	3.25	5.19	4.50	5.88		0.75	5/8	1.13	3.28	3.36	2.00	2.63	0.15	0.72	3.13	4.00	14	
QAFL11A055S	55 mm																				
QAFL11A055S	55 mm																				
QAFL13A060S	60 mm	22213	171.5	96.8	146.1	121.2	157.2	N/A	25.4	16	31.5	89.2	91.2	54.6	72.6	3.0	20.1	86.1	109.2	7.7	
QAFL13A207S	2 7/16 in.		6.75	3.81	5.75	4.77	6.19		1.00	5/8	1.24	3.51	3.59	2.15	2.86	0.12	0.79	3.39	4.30	17	
QAFL13A207S	2 7/16 in.																				
QAFL13A208S	2 1/2 in.																				
QAFL13A208S	2 1/2 in.																				
QAFL13A065S	65 mm																				
QAFL13A065S	65 mm																				

⁽¹⁾ Bearing part numbers use QA to designate single-collar units (use S_A and R_A dimensions) and QAA to designate double-collar units (use S_{AA} and R_{AA} dimensions).

⁽²⁾ Pilot tolerance: +0/-0.05 mm (+0/-0.002 in.).

⁽³⁾ Add (p) to the end of the housing designation in the part number to order with pilot using G dimension.

⁽⁴⁾ Piloted flange blocks will be quoted (price and delivery) upon request. For optional spigot on flange side, insert the letter P as seen in the following example: QMFP**J***S.

Continued on next page.

QAFL AND QAAFL SQUARE FLANGE BLOCKS

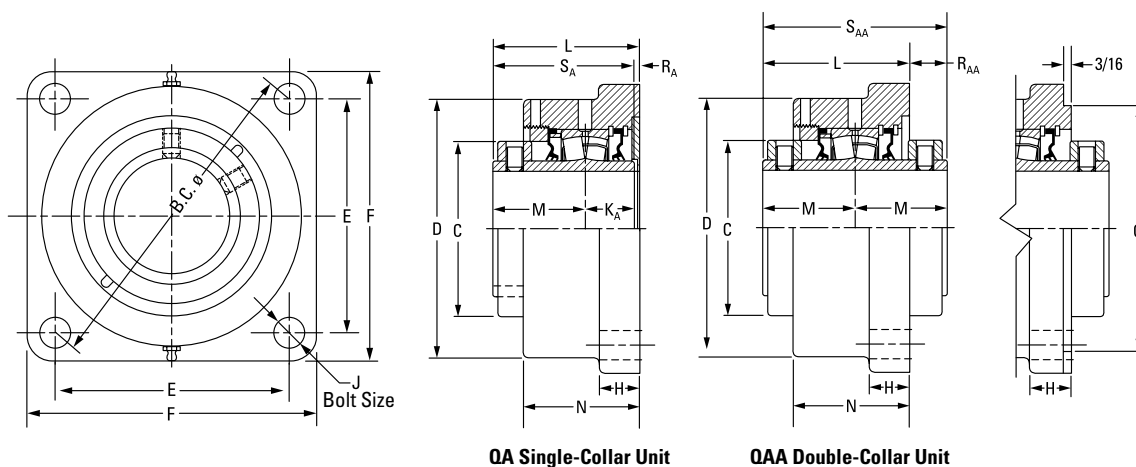

Continued from previous page.

Bearing Part No. ⁽¹⁾	Shaft Dia.	Bearing No.	B.C.	C	D	E	F	G ⁽²⁾⁽³⁾⁽⁴⁾	H	J	K _A	L FIX	L EXP	M	N	R _A	R _{AA}	S _A	S _{AA}	Wt.
			mm in.	mm in.	mm in.	mm in.	mm in.	mm in.	mm in.	mm in.	mm in.	mm in.	mm in.	mm in.	mm in.	mm in.	mm in.	mm in.	mm in.	mm in.
QAFL15A211S QAAFL15A211S	2 1/16 in.	22215	200.2 7.88	109.0 4.29	168.4 6.63	141.2 5.56	182.6 7.19	N/A	26.9 1.06	20 3/4	31.8 1.25	95.8 3.77	97.8 3.85	60.2 2.37	74.4 2.93	3.8 0.15	24.6 0.97	91.9 3.62	120.4 4.74	10.4 23
QAFL15A212S QAAFL15A212S	2 3/4 in.																			
QAFL15A070S QAAFL15A070S	70 mm																			
QAFL15A215S QAAFL15A215S	2 15/16 in.																			
QAFL15A300S QAAFL15A300S	3 in.																			
QAFL15A075S QAAFL15A075S	75 mm																			
QAFL18A303S QAAFL18A303S	3 3/16 in.	22218	241.3 9.50	130.3 5.13	193.8 7.63	170.7 6.72	212.9 8.38	187.33 7.375	32.5 1.28	20 3/4	36.6 1.44	106.4 4.19	108.5 4.27	65.8 2.59	86.4 3.40	4.1 0.16	25.1 0.99	102.4 4.03	131.6 5.18	15.9 35
QAFL18A304S QAAFL18A304S	3 1/4 in.																			
QAFL18A080S QAAFL18A080S	80 mm																			
QAFL18A085S QAAFL18A085S	85 mm																			
QAFL18A307S QAAFL18A307S	3 7/16 in.																			
QAFL18A308S QAAFL18A308S	3 1/2 in.																			
QAFL18A090S QAAFL18A090S	90 mm	22220	273.1 10.75	152.4 6.00	229.6 9.04	193.0 7.60	241.3 9.50	215.90 8.500	38.1 1.50	24 1	41.4 1.63	132.3 5.21	134.4 5.29	75.4 2.97	104.6 4.12	15.7 0.62	18.0 0.71	116.6 4.59	150.4 5.92	24.9 55
QAFL20A315S QAAFL20A315S	3 15/16 in.																			
QAFL20A400S QAAFL20A400S	4 in.																			
QAFL20A100S QAAFL20A100S	100 mm																			

⁽¹⁾ Bearing part numbers use QA to designate single-collar units (use S_A and R_A dimensions) and QAA to designate double-collar units (use S_{AA} and R_{AA} dimensions).

⁽²⁾ Pilot tolerance: +0/-0.05 mm (+0/-0.002 in.).

⁽³⁾ Add (p) to the end of the housing designation in the part number to order with pilot using G dimension.

⁽⁴⁾ Piloted flange blocks will be quoted (price and delivery) upon request. For optional spigot on flange side, insert the letter P as seen in the following example: QAFL**A***S

QAAF 5000 SERIES FLANGE BLOCKS

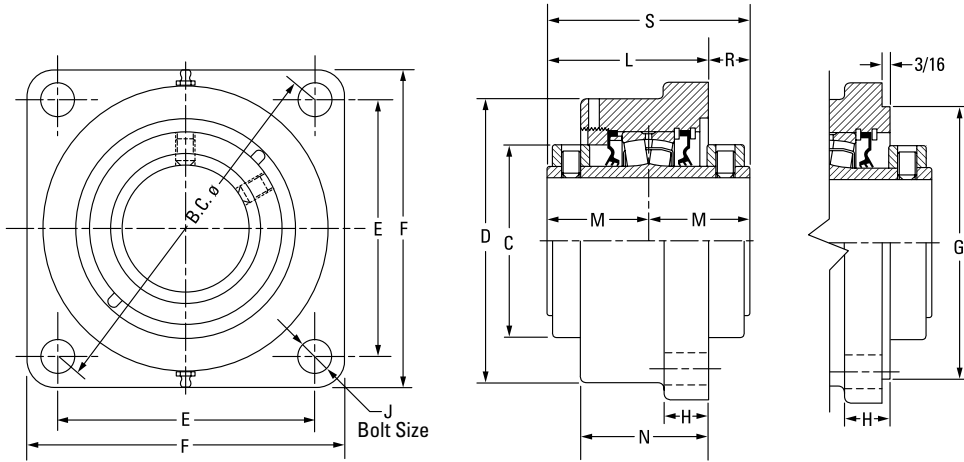

Bearing Part No.	Shaft Dia.	Bearing No.	B.C.	C	D	E	F	G ⁽¹⁾⁽²⁾⁽³⁾	H	J	L FIX	L EXP	M	N	R	S	Wt.
	mm in.		mm in.	mm in.	mm in.	mm in.	mm in.	mm in.	mm in.	mm in.	mm in.	mm in.	mm in.	mm in.	mm in.	mm in.	kg lbs.
QAAF10A115S	1 15/16 in.	22210	146.1	73.2	120.7	103.1	134.9	111.13	22.4	12	80.8	82.8	47.5	65.0	15.2	95.3	5.4
QAAF10A200S	2 in.		5.75	2.88	4.75	4.06	5.31	4.375	0.88	1/2	3.18	3.26	1.87	2.56	0.60	3.75	12
QAAF10A050S	50 mm																
QAAF11A203S	2 3/8 in.	22211	161.5	82.6	130.3	114.3	149.4	127.00	25.4	16	83.1	85.1	50.5	66.8	18.5	101.6	6.8
QAAF11A204S	2 1/4 in.		6.36	3.25	5.13	4.50	5.88	5.000	1.00	5/8	3.27	3.35	1.99	2.63	0.73	4.00	15
QAAF11A055S	55 mm																
QAAF13A060S	60 mm	22213	180.8	96.8	146.1	127.8	157.2	138.13	25.4	16	89.2	91.2	54.6	72.4	19.6	109.2	8.6
QAAF13A207S	2 7/8 in.		7.12	3.81	5.75	5.03	6.19	5.438	1.00	5/8	3.51	3.59	2.15	2.85	0.77	4.30	19
QAAF13A208S	2 1/2 in.																
QAAF13A065S	65 mm																
QAAF15A211S	2 15/16 in.	22215	215.9	109.0	168.9	152.7	189.0	160.35	26.9	20	96.0	98.0	60.2	76.2	24.4	120.4	12.7
QAAF15A212S	2 3/4 in.		8.50	4.29	6.65	6.01	7.44	6.313	1.06	3/4	3.78	3.86	2.37	3.00	0.96	4.74	28
QAAF15A070S	70 mm																
QAAF15A215S	2 15/16 in.																
QAAF15A300S	3 in.																
QAAF15A075S	75 mm																
QAAF18A303S	3 3/8 in.	22218	241.3	130.3	193.8	170.7	212.9	187.33	33.3	20	107.2	109.2	65.8	84.1	24.6	131.6	19.1
QAAF18A304S	3 1/4 in.		9.50	5.13	7.63	6.72	8.38	7.375	1.31	3/4	4.22	4.30	2.59	3.31	0.97	5.18	42
QAAF18A080S	80 mm																
QAAF18A085S	85 mm																
QAAF18A307S	3 7/8 in.																
QAAF18A308S	3 1/2 in.																
QAAF18A090S	90 mm																
QAAF20A315S	3 15/16 in.	22220	298.5	152.4	215.9	211.1	268.2	225.43	38.1	24	126.0	128.0	75.4	103.1	24.6	150.4	29.9
QAAF20A400S	4 in.		11.75	6.00	8.50	8.31	10.56	8.875	1.50	7/8	4.96	5.04	2.97	4.06	0.97	5.92	66
QAAF20A100S	100 mm																
QAAF22A110S	110 mm																
QAAF22A407S ⁽⁴⁾	4 7/8 in.	22222	327.2	160.0	256.5	163.6	384.3	263.53	31.8	24	143.8	145.8	94.0	106.9	15.0	158.8	46.3
QAAF22A408S ⁽⁴⁾	4 1/2 in.		12.88 ⁽⁴⁾	6.30	10.10	6.44 ⁽⁴⁾	15.13	10.375	1.25	7/8	5.66	5.74	3.70	4.21	0.59	6.25	102
QAAF22A115S ⁽⁴⁾	115 mm																
QAAF26A125S ⁽⁴⁾	125 mm																
QAAF26A415S ⁽⁴⁾	4 15/16 in.	22226	355.6	175.0	284.2	177.8	419.1	284.18	38.1	24	174.8	176.8	94.5	135.1	14.2	189.0	52.2
QAAF26A500S ⁽⁴⁾	5 in.		14.00 ⁽⁴⁾	6.89	11.19	7.00 ⁽⁴⁾	16.50	11.188	1.50	1	6.88	6.96	3.72	5.32	0.56	7.44	115
QAAF26A130S ⁽⁴⁾	130 mm																

⁽¹⁾Pilot tolerance: +0/-0.05 mm (+0/-0.002 in.).

⁽²⁾Add (p) to the end of the housing designation in the part number to order with pilot using G dimension.

⁽³⁾Piloted flange blocks will be quoted (price and delivery) upon request. For optional spigot on flange side, insert the letter P as seen in the following example: QMFP**J***S.

⁽⁴⁾Six-bolt round housing.

QAFY AND QAAFY ROUND FLANGE BLOCKS

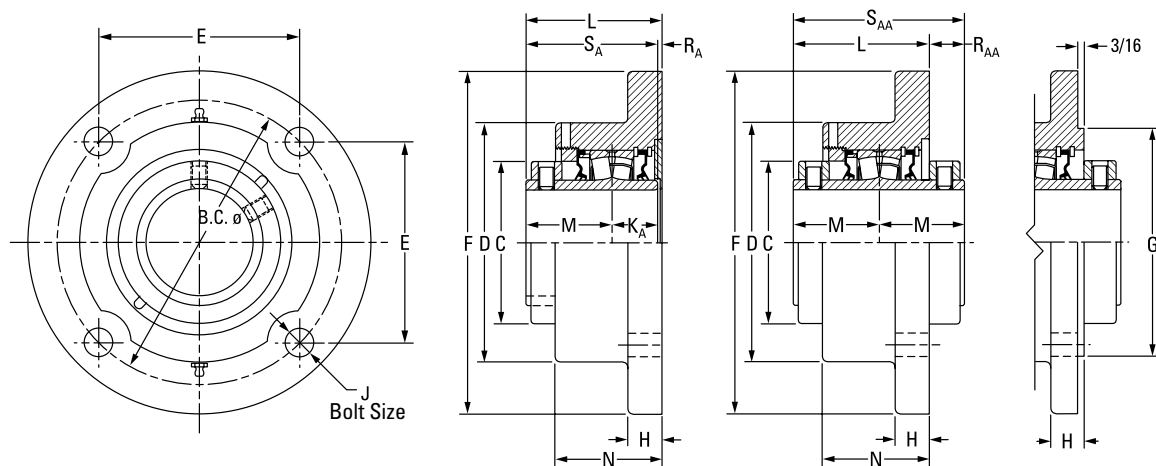

Bearing Part No. ⁽¹⁾	Shaft Dia.	Bearing No.	B.C.	C	D	E	F	G ⁽²⁾⁽³⁾⁽⁴⁾	H	J	K _A	L FIX	L EXP	M	N	R _A	R _{AA}	S _A	S _{AA}	Wt.
	mm in.		mm in.	mm in.	mm in.	mm in.	mm in.	mm in.	mm in.	mm in.	mm in.	mm in.	mm in.	mm in.	mm in.	mm in.	mm in.	mm in.	mm in.	kg lbs.
QAFY08A035S ⁽⁵⁾	35 mm																			
QAFY08A107S ⁽⁵⁾	1 7/16 in.	22208	127.0 5.00	60.5 2.38	108.0 4.25	110.0 4.33	158.8 6.25	90.50 3.563	19.1 0.75	12 1/2	25.4 1.00	73.2 2.88	75.2 2.96	44.5 1.75	57.4 2.26	3.3 0.13	—	69.9 2.75	—	4.5 10
QAFY08A108S ⁽⁵⁾	1 1/2 in.																			
QAFY09A040S	40 mm																			
QAFY09A111S	1 11/16 in.	22209	139.7 5.50	66.8 2.63	104.9 4.13	98.8 3.89	171.5 6.75	103.20 4.063	20.6 0.81	12 1/2	25.4 1.00	76.2 3.00	78.2 3.08	47.8 1.88	60.5 2.38	3.0 0.12	—	73.2 2.88	—	5.0 11
QAFY09A112S	1 3/4 in.																			
QAFY09A045S	45 mm																			
QAFY10A115S	1 15/16 in.																			
QAAFY10A115S																				
QAFY10A200S	2 in.	22210	146.1 5.75	73.2 2.88	115.3 4.54	103.4 4.07	177.8 7.00	111.13 4.375	19.1 0.75	12 1/2	25.4 1.00	75.9 2.99	78.0 3.07	47.5 1.87	57.2 2.25	3.0 0.12	20.1 0.79	72.9 2.87	95.3 3.75	5.4 12
QAAFY10A200S																				
QAFY10A050S	50 mm																			
QAAFY10A050S																				
QAFY11A203S	2 3/16 in.																			
QAAFY11A203S																				
QAFY11A204S	2 1/4 in.	22211	162.1 6.38	82.6 3.25	130.3 5.13	114.3 4.50	196.9 7.75	127.00 5.000	19.1 0.75	16 5/8	28.7 1.13	82.3 3.24	84.3 3.32	50.8 2.00	62.0 2.44	3.0 0.12	19.3 0.76	79.5 3.13	101.6 4.00	6.8 15
QAAFY11A204S																				
QAFY11A055S	55 mm																			
QAAFY11A055S																				
QAFY13A060S	60 mm																			
QAAFY13A060S																				
QAFY13A207S	2 7/16 in.	22213	171.5 6.75	96.8 3.81	146.1 5.75	121.2 4.77	206.5 8.13	138.13 5.438	23.9 0.94	16 5/8	31.5 1.24	91.2 3.49	93.2 3.67	54.6 2.15	72.4 2.85	5.1 0.20	20.6 0.81	86.1 3.39	109.2 4.30	8.6 19
QAAFY13A207S																				
QAFY13A208S	2 1/2 in.																			
QAAFY13A208S																				
QAFY13A065S	65 mm																			
QAAFY13A065S																				

⁽¹⁾ Bearing part numbers use QA to designate single-collar units (use S_A and R_A dimensions) and QAA to designate double-collar units (use S_{AA} and R_{AA} dimensions).

⁽²⁾ Pilot tolerance: +0/-0.05 mm (+0/-0.002 in.).

⁽³⁾ Add (p) to the end of the housing designation in the part number to order with pilot using G dimension.

⁽⁴⁾ Piloted flange blocks will be quoted (price and delivery) upon request. For optional spigot on flange side, insert the letter P as seen in the following example: QMFP**J***S.

⁽⁵⁾ Three-bolt housing.

⁽⁶⁾ Six-bolt housing.

Continued on next page.

QAFY AND QAAFY ROUND FLANGE BLOCKS – continued

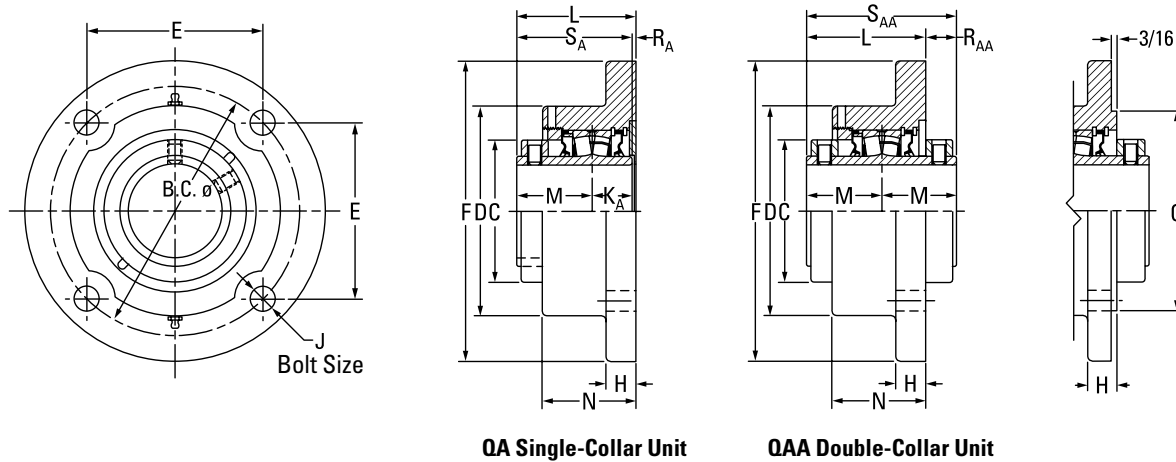

QA Single-Collar Unit

QAA Double-Collar Unit

Continued from previous page.

Bearing Part No. ⁽¹⁾	Shaft Dia.	Bearing No.	B.C.	C	D	E	F	G ⁽²⁾⁽³⁾⁽⁴⁾	H	J	KA	L FIX	L EXP	M	N	RA	RAA	SA	SAA	Wt.	
	mm in.		mm in.	mm in.	mm in.	mm in.	mm in.	mm in.	mm in.	mm in.	mm in.	mm in.	mm in.	mm in.	mm in.	mm in.	mm in.	mm in.	mm in.	kg lbs.	
QAFY15A211S QAAFY15A211S	2 1/16 in.	22215	200.2 7.88	109.0 4.29	168.4 6.63	141.5 5.57	241.3 9.50	160.35 6.313	23.9 0.94	20 3/4	31.8 1.25	98.3 3.87	100.3 3.95	60.2 2.37	74.4 2.93	6.4 0.25	21.8 0.86	91.9 3.62	120.4 4.74	12.7 28	
QAFY15A212S QAAFY15A212S	2 3/4 in.																				
QAFY15A070S QAAFY15A070S	70 mm																				
QAFY15A215S QAAFY15A215S	2 1/8 in.																				
QAFY15A300S QAAFY15A300S	3 in.																				
QAFY15A075S QAAFY15A075S	75 mm																				
QAFY18A303S QAAFY18A303S	3 3/16 in.	22218	241.3 9.50	130.3 5.13	193.8 7.63	170.7 6.72	282.7 11.13	N/A	28.7 1.13	24 7/8	36.6 1.44	108.7 4.28	110.7 4.36	65.8 2.59	85.3 3.36	6.4 0.25	22.9 0.90	102.4 4.03	131.6 5.18	19.1 42	
QAFY18A304S QAAFY18A304S	3 1/4 in.																				
QAFY18A080S QAAFY18A080S	80 mm																				
QAFY18A085S QAAFY18A085S	85 mm																				
QAFY18A307S QAAFY18A307S	3 7/16 in.																				
QAFY18A308S QAAFY18A308S	3 1/2 in.																				
QAFY18A090S QAAFY18A090S	90 mm	22220	273.1 10.75	152.4 6.00	222.5 8.76	193.0 7.60	320.8 12.63	N/A	28.7 1.13	24 1	41.4 1.63	123.7 4.87	125.7 4.95	75.4 2.97	103.1 4.06	6.9 0.27	26.7 1.05	116.6 4.59	150.4 5.92	29.9 66	
QAFY20A315S QAAFY20A315S	3 1/8 in.																				
QAFY20A400S QAAFY20A400S	4 in.																				
QAFY20A100S QAAFY20A100S	100 mm																				
QAFY22A110S ⁽⁶⁾ QAAFY22A110S ⁽⁶⁾	110 mm																				
QAFY22A407S ⁽⁶⁾ QAAFY22A407S ⁽⁶⁾	4 7/16 in.																				
QAFY22A408S ⁽⁶⁾ QAAFY22A408S ⁽⁶⁾	4 1/2 in.	22222	327.2 12.88 ⁽⁵⁾	160.0 6.30	254.0 10.00	163.6 6.44 ⁽⁵⁾	384.3 15.13	N/A	31.8 1.25	24 1 ⁽⁵⁾	-	129.0 5.08	131.1 5.16	79.5 3.13	100.3 3.95	-	30.0 1.18	-	158.8 6.25	46.3 102	
QAFY22A115S ⁽⁶⁾ QAAFY22A115S ⁽⁶⁾	115 mm																				
QAFY26A125S ⁽⁶⁾ QAAFY26A125S ⁽⁶⁾	125 mm	22226	355.6 14.00 ⁽⁵⁾	175.0 6.89	284.2 11.19	177.8 7.00 ⁽⁵⁾	419.1 16.50	N/A	38.1 1.50	27 1 1/8 ⁽⁵⁾	-	169.9 6.69	172.0 6.77	94.5 3.72	139.7 5.50	-	19.1 0.75	-	189.0 7.44	52.2 115	
QAFY26A415S ⁽⁶⁾ QAAFY26A415S ⁽⁶⁾	4 1/8 in.																				
QAFY26A500S ⁽⁶⁾ QAAFY26A500S ⁽⁶⁾	5 in.																				
QAFY26A130S ⁽⁶⁾ QAAFY26A130S ⁽⁶⁾	130 mm																				

⁽¹⁾ Bearing part numbers use QA to designate single-collar units (use SA and RA dimensions) and QAA to designate double-collar units (use SAA and RAA dimensions).

⁽²⁾ Pilot tolerance: +0/-0.05 mm (+0/-0.002 in.).

⁽³⁾ Add (p) to the end of the housing designation in the part number to order with pilot using G dimension.

⁽⁴⁾ Piloted flange blocks will be quoted (price and delivery) upon request. For optional spigot on flange side, insert the letter P as seen in the following example: QMFP**J***S.

⁽⁵⁾ Three-bolt housing.

⁽⁶⁾ Six-bolt housing.

QAMC AND QAAMC CARTRIDGE BLOCKS

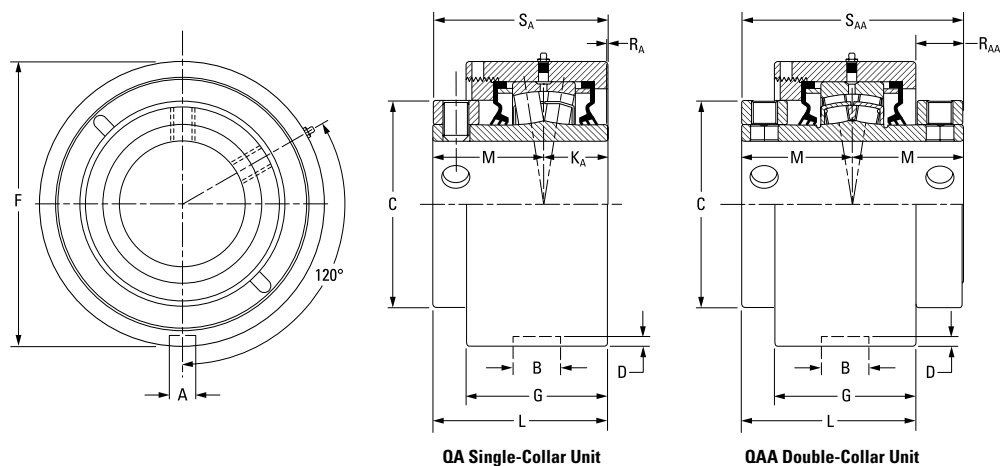

Bearing Part No. ⁽¹⁾	Shaft Dia.	Bearing No.	A	B	C	D	F	G	K _A	L FIX	L EXP	M	R _A	R _{AA}	S _A	S _{AA}	Wt.
	mm in.		mm in.	mm in.	mm in.	mm in.	mm in.	mm in.	mm in.	mm in.	mm in.	mm in.	mm in.	mm in.	mm in.	mm in.	kg lbs.
QAMC10A115S QAAMC10A115S	1 1/8 in.	22210	13.5 0.53	23.1 0.91	73.2 2.88	4.8 0.19	104.78 (+0/-0.05) 4.125 (+0/-0.002)	62.2 2.45	25.4 1.00	79.2 3.12	81.3 3.20	47.5 1.87	6.1 0.24	16.8 0.66	72.9 2.87	95.3 3.75	3.6 8
QAMC10A200S QAAMC10A200S	2 in.																
QAMC10A050S QAAMC10A050S	50 mm																
QAMC11A203S QAAMC11A203S	2 3/8 in.	22211	13.5 0.53	23.1 0.91	82.6 3.25	4.8 0.19	115.09 (+0/-0.05) 4.531 (+0/-0.002)	65.5 2.58	28.7 1.13	83.8 3.30	85.9 3.38	50.8 2.00	4.1 0.16	18.0 0.71	79.5 3.13	101.6 4.00	4.5 10
QAMC11A204S QAAMC11A204S	2 1/4 in.																
QAMC11A055S QAAMC11A055S	55 mm																
QAMC13A060S QAAMC13A060S	60 mm	22213	13.5 0.53	23.1 0.91	96.8 3.81	3.6 0.14	127.00 (+0/-0.05) 5.000 (+0/-0.002)	69.3 2.73	31.5 1.24	85.9 3.38	87.9 3.46	54.6 2.15	0.0 0.00	14.0 0.55	86.1 3.39	109.2 4.30	5.4 12
QAMC13A207S QAAMC13A207S	2 7/8 in.																
QAMC13A208S QAAMC13A208S	2 1/2 in.																
QAMC13A065S QAAMC13A065S	65 mm	22215	15.0 0.59	26.2 1.03	109.0 4.29	6.4 0.25	149.225 (+0/-0.05) 5.875 (+0/-0.002)	79.8 3.14	31.8 1.25	100.6 3.96	102.6 4.04	60.2 2.37	8.1 0.32	19.8 0.78	91.9 3.62	120.4 4.74	8.2 18
QAMC15A211S QAAMC15A211S	2 11/16 in.																
QAMC15A212S QAAMC15A212S	2 3/4 in.																
QAMC15A070S QAAMC15A070S	70 mm																
QAMC15A215S QAAMC15A215S	2 15/16 in.																
QAMC15A300S QAAMC15A300S	3 in.																
QAMC15A075S QAAMC15A075S	75 mm																

⁽¹⁾Bearing part numbers use QA to designate single-collar units (use S_A and R_A dimensions) and QAA to designate double-collar units (use S_{AA} and R_{AA} dimensions).

Continued on next page.

QAMC AND QAAMC CARTRIDGE BLOCKS – continued

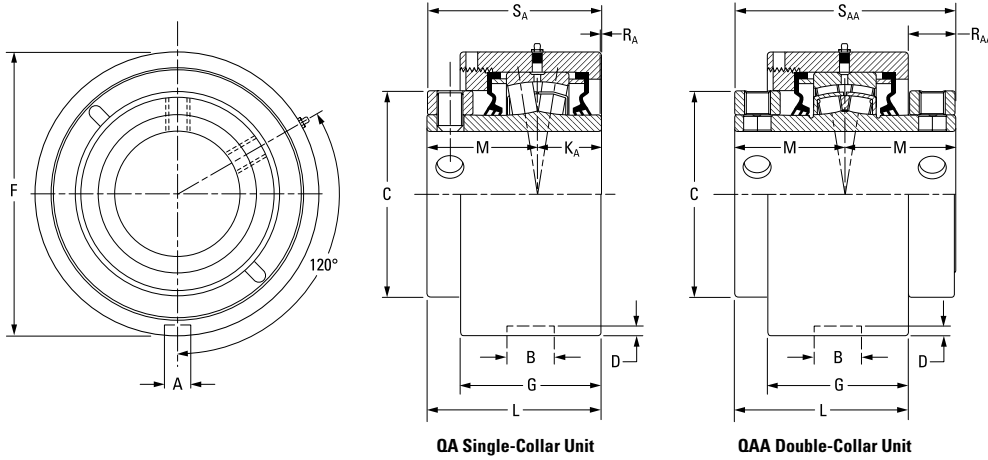

Continued from previous page.

Bearing Part No. ⁽¹⁾	Shaft Dia.	Bearing No.	A	B	C	D	F	G	K _A	L FIX	L EXP	M	R _A	R _{AA}	S _A	S _{AA}	Wt.
	mm in.		mm in.	mm in.	mm in.	mm in.	mm in.	mm in.	mm in.	mm in.	mm in.	mm in.	mm in.	mm in.	mm in.	mm in.	kg lbs.
QAMC18A303S QAAMC18A303S	3 3/8 in.	22218	15.0 0.59	26.9 1.06	130.3 5.13	5.8 0.23	171.45 (+0/-0.05) 6.750 (+0/-0.002)	87.6 3.45	36.6 1.44	110.2 4.34	112.3 4.42	65.8 2.59	7.4 0.29	21.3 0.84	102.4 4.03	131.6 5.18	11.8 26
QAMC18A304S QAAMC18A304S	3 1/4 in.																
QAMC18A080S QAAMC18A080S	80 mm																
QAMC18A085S QAAMC18A085S	85 mm																
QAMC18A307S QAAMC18A307S	3 7/8 in.																
QAMC18A308S QAAMC18A308S	3 1/2 in.																
QAMC18A090S QAAMC18A090S	90 mm																
QAMC20A315S QAAMC20A315S	3 15/16 in.	22220	19.8 0.78	32.5 1.28	152.4 6.00	7.9 0.31	206.375 (+0/-0.05) 8.125 (+0/-0.002)	105.2 4.14	41.4 1.63	128.3 5.05	130.3 5.13	75.4 2.97	11.4 0.45	22.6 0.89	116.6 4.59	150.9 5.94	14.5 32
QAMC20A400S QAAMC20A400S	4 in.																
QAMC20A100S QAAMC20A100S	100 mm																
QAAMC22A110S	110 mm	22222	19.8 0.78	38.1 1.50	160.0 6.30	7.9 0.31	222.25 (+0/-0.08) 8.75 (+0/-0.003)	108.5 4.27	-	133.6 5.26	135.6 5.34	79.5 3.13	-	25.1 0.99	-	158.8 6.25	18.1 40
QAAMC22A407S	4 7/8 in.																
QAAMC22A408S	4 1/2 in.																
QAAMC22A115S	115 mm	22226	19.8 0.78	38.1 1.50	175.0 6.89	7.9 0.31	265.13 (+0/-0.08) 10.438 (+0/-0.003)	141.7 5.58	-	165.4 6.51	167.4 6.59	94.5 3.72	-	23.6 0.93	-	189.0 7.44	18.1 40
QAAMC26A125S	125 mm																
QAAMC26A415S	4 15/16 in.																
QAAMC26A500S	5 in.																
QAAMC26A130S	130 mm																

⁽¹⁾Bearing part numbers use QA to designate single-collar units (use S_A and R_A dimensions) and QAA to designate double-collar units (use S_{AA} and R_{AA} dimensions).

QATU AND QAATU TAKE-UP BLOCKS

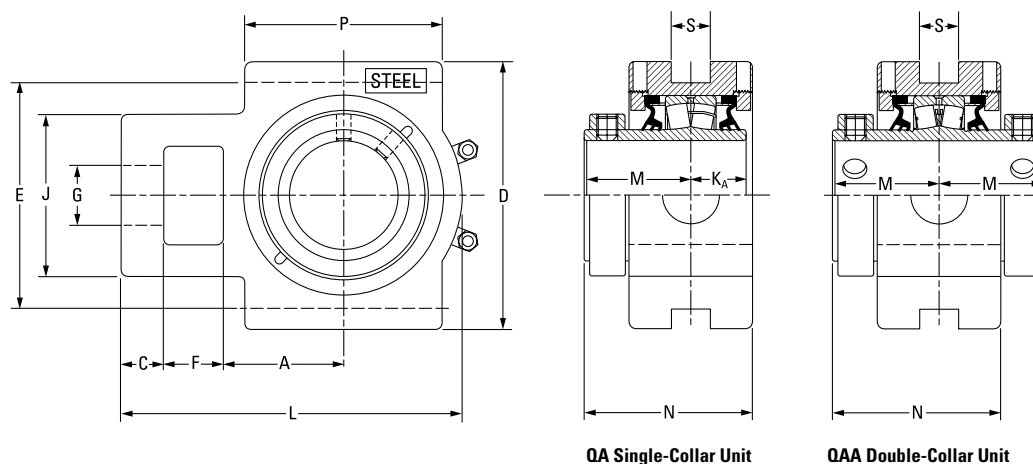

Bearing Part No. ⁽¹⁾	Shaft Dia.	Bearing No.	A	C	D	E	F	G	J	K _A	L	M	N	P	S	Wt.
	mm in.		mm in.	mm in.	mm in.	mm in.	mm in.	mm in.	mm in.	mm in.	mm in.	mm in.	mm in.	mm in.	mm in.	kg lbs.
QATU10A115S QAATU10A115S	1 15/16 in.	22210	54.1 2.13	19.1 0.75	120.7 4.75	101.6 4.00	26.9 1.06	26.9 1.06	73.2 2.88	25.4 1.00	153.4 6.04	47.5 1.87	75.7 2.98	88.9 3.50	17.5 0.69	7.7 17
QATU10A200S QAATU10A200S	2 in.															
QATU10A050S QAATU10A050S	50 mm															
QATU11A203S QAATU11A203S	2 3/16 in.	22211	60.5 2.38	19.1 0.75	133.4 5.25	114.3 4.50	28.7 1.13	30.2 1.19	88.9 3.50	28.7 1.13	167.9 6.61	50.8 2.00	81.8 3.22	95.3 3.75	20.6 0.81	9.5 21
QATU11A204S QAATU11A204S	2 1/4 in.															
QATU11A055S QAATU11A055S	55 mm															
QATU13A060S QAATU13A060S	60 mm	22213	69.9 2.75	22.4 0.88	149.4 5.88	130.3 5.13	33.3 1.31	35.1 1.38	95.3 3.75	31.5 1.24	193.8 7.63	54.6 2.15	91.2 3.59	120.7 4.75	26.9 1.06	12.2 27
QATU13A207S QAATU13A207S	2 7/16 in.															
QATU13A208S QAATU13A208S	2 1/2 in.															
QATU13A065S QAATU13A065S	65 mm	22215	76.2 3.00	25.4 1.00	171.5 6.75	150.9 5.94	39.6 1.56	39.6 1.56	108.0 4.25	31.8 1.25	219.7 8.65	60.2 2.37	97.0 3.82	120.7 4.75	46.0 1.81	15.9 35
QATU15A211S QAATU15A211S	2 11/16 in.															
QATU15A212S QAATU15A212S	2 3/4 in.															
QATU15A070S QAATU15A070S	70 mm															
QATU15A215S QAATU15A215S	2 15/16 in.															
QATU15A300S QAATU15A300S	3 in.															
QATU15A075S QAATU15A075S	75 mm															

⁽¹⁾Bearing part numbers use QA to designate single-collar units and QAA to designate double-collar units.
NOTE: Please refer to page 206 for take-up frames.

Continued on next page.

QATU AND QAATU TAKE-UP BLOCKS – continued

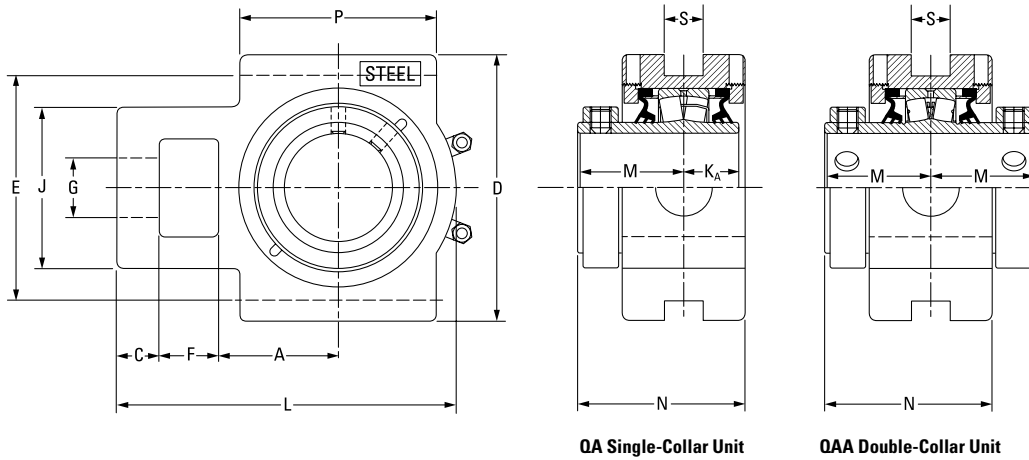

Continued from previous page.

Bearing Part No. ⁽¹⁾	Shaft Dia.	Bearing No.	A	C	D	E	F	G	J	K _A	L	M	N	P	S	Wt.															
	mm in.		mm in.	mm in.	mm in.	mm in.	mm in.	mm in.	mm in.	mm in.	mm in.	mm in.	mm in.	mm in.	mm in.	kg lbs.															
QATU18A303S QAATU18A303S	3 3/8 in.	22218	92.2 3.63	25.4 1.00	193.8 7.63	173.0 6.81	46.0 1.81	47.8 1.88	124.0 4.88	36.6 1.44	257.0 10.12	65.8 2.59	107.2 4.22	158.8 6.25	46.0 1.81	20.0 44															
QATU18A304S QAATU18A304S	3 1/4 in.																														
QATU18A080S QAATU18A080S	80 mm																														
QATU18A085S QAATU18A085S	85 mm																														
QATU18A307S QAATU18A307S	3 7/8 in.																														
QATU18A308S QAATU18A308S	3 1/2 in.																														
QATU18A090S QAATU18A090S	90 mm																														
QATU20A315S QAATU20A315S	3 15/16 in.																22220	104.9 4.13	28.7 1.13	239.8 9.44	219.2 8.63	54.1 2.13	52.3 2.06	143.0 5.63	41.4 1.63	296.9 11.69	75.4 2.97	121.7 4.79	177.8 7.00	52.3 2.06	26.3 58
QATU20A400S QAATU20A400S	4 in.																														
QATU20A100S QAATU20A100S	100 mm																														
QAATU22A110S	110 mm	22222	128.5 5.06	38.1 1.50	263.7 10.38	241.3 9.50	54.1 2.13	54.1 2.13	162.1 6.38	-	341.4 13.44	79.5 3.13	143.8 5.66	199.9 7.87	52.3 2.06	36.4 80															
QAATU22A407S	4 7/8 in.																														
QAATU22A408S	4 1/2 in.																														
QAATU22A115S	115 mm	22226	134.9 5.31	63.5 2.50	285.8 11.25	260.4 10.25	63.5 2.50	60.5 2.38	177.8 7.00	-	396.7 15.62	94.5 3.72	150.9 5.94	228.6 9.00	52.3 2.06	60.8 134															
QAATU26A125S	125 mm																														
QAATU26A415S	4 15/16 in.																														
QAATU26A500S	5 in.																														
QAATU26A130S	130 mm																														

⁽¹⁾Bearing part numbers use QA to designate single-collar units and QAA to designate double-collar units.
NOTE: Please refer to page 206 for take-up frames.

QATP AND QAATP TOP PULL TAKE-UP BLOCKS

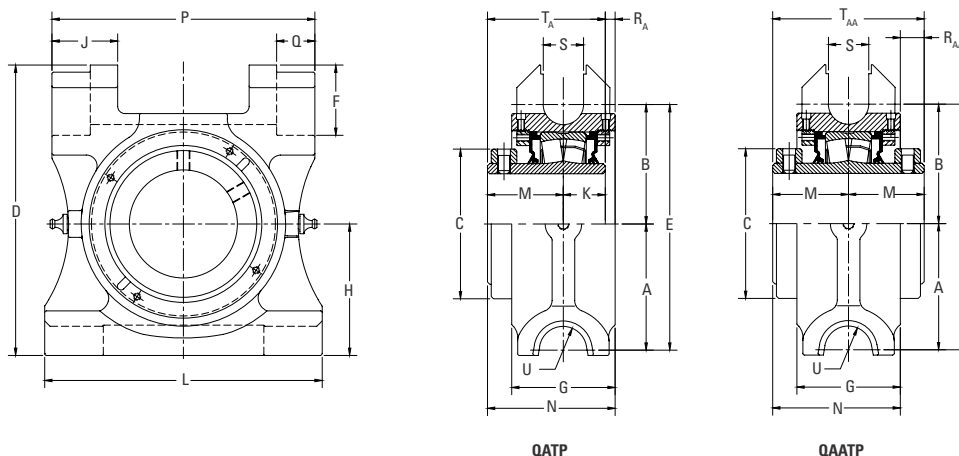

Bearing Part No.	Shaft Dia.	Bearing No.	A	B	C	D	E	F	G	H	J	K	L	M	N	P	Q	R _A	R _{AA}	S	T _A	T _{AA}	U
	mm in.		mm in.	mm in.	mm in.	mm in.	mm in.	mm in.	mm in.	mm in.	mm in.	mm in.	mm in.	mm in.	mm in.	mm in.	mm in.	mm in.	mm in.	mm in.	mm in.	mm in.	kg lbs.
QATP10A115S QAATP10A115S	1 15/16 in.	22210	71.4 2.81	60.5 2.38	73.0 2.88	163.6 6.44	131.8 5.19	42.2 1.66	62.7 2.47	77.8 3.06	41.9 1.65	25.0 0.98	165.1 6.50	48.0 1.89	79.3 3.12	152.4 6.00	20.6 0.81	6.3 0.25	16.7 0.66	22.4 0.88	73.0 2.87	96.0 3.78	20.6 0.81
QATP10A200S QAATP10A200S	2 in.																						
QATP10A050S QAATP10A050S	50 mm																						
QATP11A203S QAATP11A203S	2 3/16 in.	22211	82.6 3.25	72.8 2.87	82.6 3.25	193.8 7.63	158.8 6.25	49.3 1.94	69.9 2.75	88.9 3.50	44.4 1.75	28.7 1.13	190.6 7.50	50.8 2.00	88.5 3.49	177.8 7.0	26.9 1.06	9.0 0.36	13.1 0.51	98.4 1.12	79.5 3.13	101.6 4.0	20.6 0.81
QATP11A204S QAATP11A204S	2 1/4 in.																						
QATP11A055S QAATP11A055S	55 mm																						
QATP13A207S QAATP13A207S	2 7/16 in.	22213	96.8 3.81	84.6 3.33	96.6 3.81	210.3 8.28	181.4 7.14	47.8 1.88	81.0 3.19	97.5 3.84	44.5 1.75	31.5 1.24	215.9 8.50	54.5 2.15	95.0 3.74	203.2 8.00	26.9 1.06	9.0 0.35	14.0 0.55	28.4 1.12	86.0 3.39	109.0 4.29	20.6 0.81
QATP13A208S QAATP13A208S	2 1/2 in.																						
QATP13A060S QAATP13A060S	60 mm																						
QATP15A211S QAATP15A211S	2 11/16 in.	22215	97.0 3.82	84.1 3.31	108.9 4.29	215.9 8.50	181.1 7.13	49.3 1.94	81.0 3.19	101.4 3.99	44.4 1.75	31.8 1.25	215.9 8.50	60.2 2.37	100.7 3.96	203.2 8.00	26.9 1.06	8.7 0.34	19.7 0.78	28.4 1.12	92.0 3.62	120.4 4.74	20.6 0.81
QATP15A212S QAATP15A212S	2 3/4 in.																						
QATP15A070S QAATP15A070S	70 mm																						
QATP15A215S QAATP15A215S	2 15/16 in.																						
QATP15A300S QAATP15A300S	3 in.																						
QATP15A075S QAATP15A075S	75 mm																						

Continued on next page.

QATP AND QAATP TOP PULL TAKE-UP BLOCKS – continued

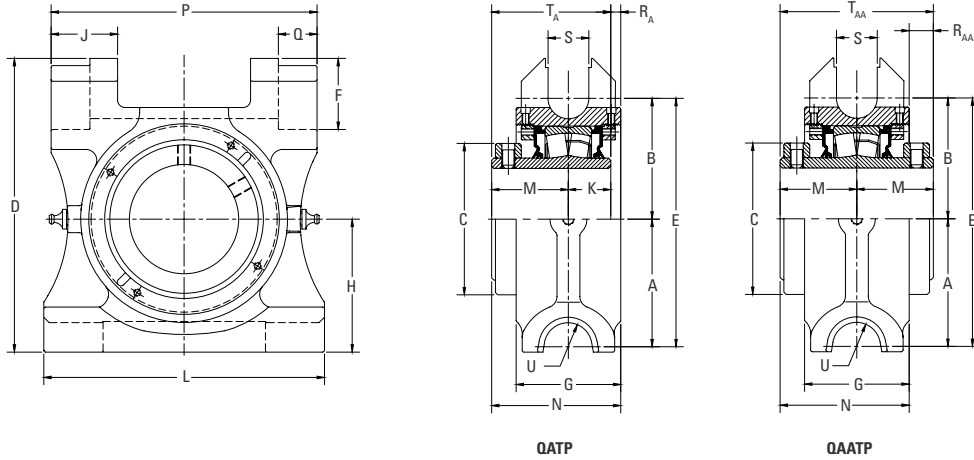

Continued from previous page.

Bearing Part No.	Shaft Dia.	Bearing No.	A	B	C	D	E	F	G	H	J	K	L	M	N	P	Q	R _A	R _{AA}	S	T _A	T _{AA}	U																						
	mm in.		mm in.	mm in.	mm in.	mm in.	mm in.	mm in.	mm in.	mm in.	mm in.	mm in.	mm in.	mm in.	mm in.	mm in.	mm in.	mm in.	mm in.	mm in.	mm in.	mm in.	kg lbs.																						
QATP18A303S QAATP18A303S	3 3/8 in.	22218	109.7 4.32	103.9 4.09	130.2 5.13	252.5 9.94	213.6 8.41	61.3 2.41	90.0 3.54	114.3 4.50	57.1 2.25	36.5 1.44	241.3 9.50	65.9 2.59	110.9 4.37	228.6 9.00	33.3 1.31	8.6 0.34	20.8 0.82	35.1 1.38	102.4 4.03	131.8 5.19	20.6 0.81																						
QATP18A304S QAATP18A304S	3 1/4 in.																																												
QATP18A080S QAATP18A080S	80 mm																																												
QATP18A085S QAATP18A085S	85 mm																																												
QATP18A307S QAATP18A307S	3 7/8 in.																																												
QATP18A308S QAATP18A308S	3 1/2 in.																																												
QATP18A090S QAATP18A090S	90 mm																																												
QATP20A311S QAATP20A311S	3 11/16 in.																							22220	121.0 4.76	117.6 4.63	152.4 6.00	289.1 11.38	234.9 9.25	63.5 2.50	79.5 3.13	139.7 5.50	58.7 2.31	41.3 1.63	279.4 11.00	75.4 2.97	126.1 4.97	266.7 10.50	33.3 1.31	9.4 0.37	24.7 0.97	35.1 1.38	116.7 4.59	150.8 5.94	20.6 0.81
QATP20A312S QAATP20A312S	3 3/4 in.																																												
QATP20A315S QAATP20A315S	3 15/16 in.																																												
QATP20A400S QAATP20A400S	4 in.																																												
QATP20A100S QAATP20A100S	100 mm																																												

QAMH AND QAAMH HANGER BLOCKS

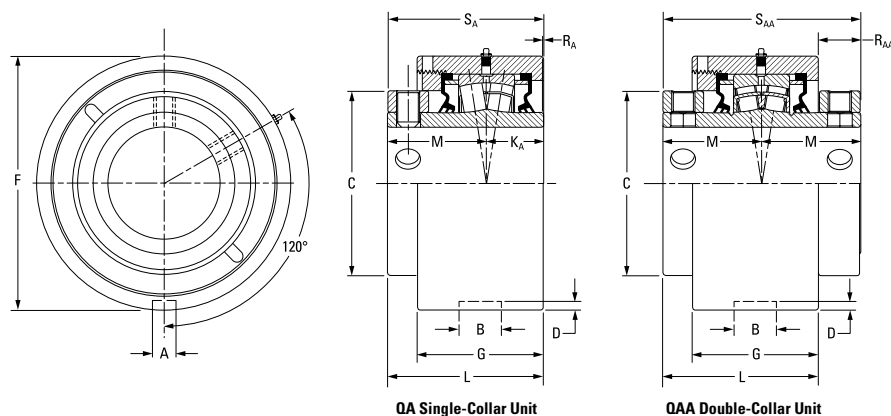

Bearing Part No.	Shaft Dia.	Bearing No.	A	B	C	D	E	F	G	J	K _A	L	M	R _A	R _{AA}	S _A	S _{AA}	Wt.
	mm in.		mm in.	mm in.	mm in.	mm in.	mm in.	mm in.	mm in.	in.	mm in.	mm in.	mm in.	mm in.	mm in.	mm in.	mm in.	kg lbs.
QAMH15A211S QAAMH15A211S	2 1/16 in.	22215	131.8 5.19	212.9 8.38	109.0 4.29	162.1 6.38	50.8 2.00	50.8 2.00	69.9 2.75	1-8UNC	31.8 1.25	91.9 3.62	60.2 2.37	0.0 0.00	28.4 1.12	91.9 3.62	120.7 4.75	10.0 22
QAMH15A212S QAAMH15A212S	2 3/4 in.																	
QAMH15A070S QAAMH15A070S	70 mm																	
QAMH15A215S QAAMH15A215S	2 1/16 in.																	
QAMH15A300S QAAMH15A300S	3 in.																	
QAMH15A075S QAAMH15A075S	75 mm																	
QAMH18A303S QAAMH18A303S	3 3/16 in.	22218	160.3 6.31	260.4 10.25	130.3 5.13	200.2 7.88	63.5 2.50	76.2 3.00	76.2 3.00	1 1/4-7UNC	36.6 1.44	99.3 3.91	65.8 2.59	3.0 0.12	32.3 1.27	102.4 4.03	131.6 5.18	16.3 36
QAMH18A304S QAAMH18A304S	3 1/4 in.																	
QAMH18A080S QAAMH18A080S	80 mm																	
QAMH18A085S QAAMH18A085S	85 mm																	
QAMH18A307S QAAMH18A307S	3 7/16 in.																	
QAMH18A308S QAAMH18A308S	3 1/2 in.																	
QAMH18A090S QAAMH18A090S	90 mm																	



EC SERIES

The reduced eccentric offset of our EC series locking collar results in a secure shaft lock that is designed not to release from a properly prepared shaft. EC series housed units also are suitable for reversing applications.

The following topics are covered within this section:

Introduction	150
QMP Two-Bolt Pillow Blocks	151
QMPL Two-Bolt Pillow Blocks	152
QMPF Four-Bolt Pillow Blocks	153
QMPR Four-Bolt Pillow Blocks	154
QMPH/QMPG Four-Bolt Pillow Blocks	155
QMPX 5000 Series Four-Bolt Pillow Blocks	156
QMPXT 5000 Series Two-Bolt Pillow Blocks	158
QMSN SN-Style Two-Bolt Pillow Blocks	159
QMC Piloted Flange Cartridges	161
QMCW Piloted Flange Cartridges	162
QMF Four-Bolt Square Flange Blocks	164
QMFL Four-Bolt Square Flange Blocks	165
QMFY Round Flange Blocks	166
QMFY 5000 Series Square Flange Blocks	168
QMMC Cartridge Blocks	170
QMTU Take-Up Blocks	172
QMTU Top Pull Take-Up Blocks	173
QMMH Hanger Blocks	174

EC SERIES

Fig. 49. EC series eccentric lock.

YOU HAVE CHOICES

For the EC series, you can select from many seal configurations and housing styles, which are shown on page 15.

HOUSINGS

- Two-bolt pillow blocks
- Four-bolt pillow blocks
- Flange blocks
- Piloted flange cartridges
- Take-up blocks
- Cartridge blocks
- Hanger blocks

SEALS

- Labyrinth: DuPont™ Teflon® (T)
- Triple-lip: nitrile rubber (M), urethane (O) and Viton® (N)
- Double-lip: nitrile rubber (B) and Viton (C)
- Steel and urethane closed-end covers (CS)
- Steel and urethane open-end covers (CJ) with:
 - DuPont Teflon (T)
 - Triple-lip seal (DR)
 - V-ring seal (VR)
- Piloted flange cartridge backing plates (HSY) with:
 - Triple-lip seal (DR)
- Flange block backing plates (UFP)
 - V-ring (VR)

QMP TWO-BOLT PILLOW BLOCKS

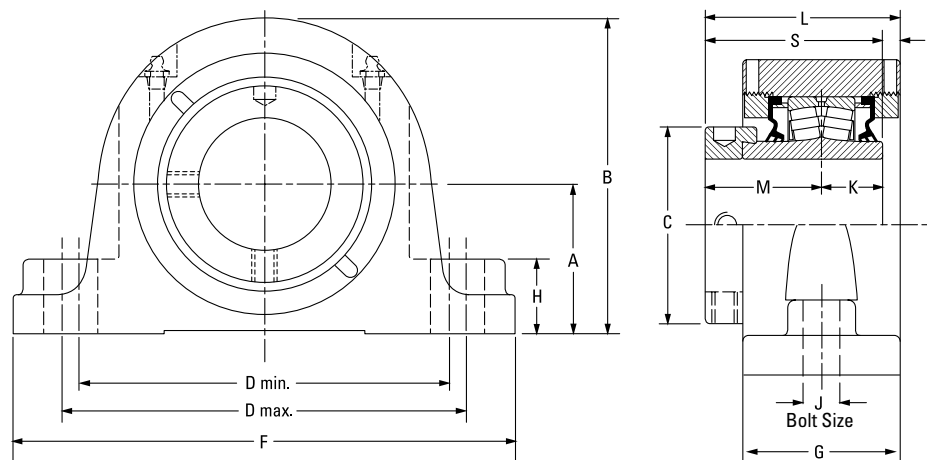

Bearing Part No.	Shaft Dia.	Bearing No.	A	B	C	D min.	D max.	F	G	H	J	K	L	M	R	S	Wt.
			mm in.	mm in.	mm in.	mm in.	mm in.	mm in.	mm in.	mm in.	mm in.	mm in.	mm in.	mm in.	mm in.	mm in.	mm in.
QMP08J035S	35 mm	22208	47.8	94.7	60.5	119.1	152.4	174.8	57.2	25.4	12	25.4	73.2	44.5	3.3	69.9	4.1
QMP08J107S	1 7/16 in.		1.88	3.73	2.38	4.69	6.00	6.88	2.25	1.00	1/2	1.00	2.88	1.75	0.13	2.75	9
QMP08J108S	1 1/2 in.	22208	54.1	101.1	60.5	119.1	165.1	200.2	57.2	25.4	12	25.4	73.2	44.5	3.3	69.9	4.1
			2.13	3.98	2.38	4.69	6.50	7.88	2.25	1.00	1/2	1.00	2.88	1.75	0.13	2.75	9
QMP09J111S	1 1/16 in.	22209	54.1	104.9	66.5	144.8	165.1	200.2	60.2	31.8	12	25.4	77.7	47.8	4.8	73.2	4.5
			2.13	4.13	2.62	5.70	6.50	7.88	2.37	1.25	1/2	1.00	3.06	1.88	0.19	2.88	10
QMP09J040S	40 mm	22209	57.2	108.0	66.5	158.8	180.8	225.6	62.0	31.8	16	25.4	78.7	47.8	5.8	73.2	4.5
QMP09J112S	1 3/4 in.		2.25	4.25	2.62	6.25	7.12	8.88	2.44	1.25	5/8	1.00	3.10	1.88	0.23	2.88	10
QMP09J045S	45 mm		57.2	108.0	66.5	158.8	180.8	225.6	62.0	31.8	16	25.4	78.7	47.8	5.8	73.2	4.5
			2.25	4.25	2.62	6.25	7.12	8.88	2.44	1.25	5/8	1.00	3.10	1.88	0.23	2.88	10
QMP10J115S	1 1/16 in.	22210	57.2	122.2	71.4	152.4	181.1	225.6	62.0	31.8	16	25.4	79.0	47.5	6.1	72.9	5.9
QMP10J200S	2 in.		2.25	4.81	2.81	6.00	7.13	8.88	2.44	1.25	5/8	1.00	3.11	1.87	0.24	2.87	13
QMP10J050S	50 mm		57.2	122.2	71.4	152.4	181.1	225.6	62.0	31.8	16	25.4	79.0	47.5	6.1	72.9	5.9
			2.25	4.81	2.81	6.00	7.13	8.88	2.44	1.25	5/8	1.00	3.11	1.87	0.24	2.87	13
QMP11J203S	2 3/16 in.	22211	63.5	133.4	75.9	165.1	200.2	244.6	66.8	31.8	16	28.7	84.1	50.8	4.8	79.5	7.7
QMP11J204S	2 1/4 in.		2.50	5.25	2.99	6.50	7.88	9.63	2.63	1.25	5/8	1.13	3.31	2.00	0.19	3.13	17
QMP11J055S	55 mm		63.5	133.4	75.9	165.1	200.2	244.6	66.8	31.8	16	28.7	84.1	50.8	4.8	79.5	7.7
			2.50	5.25	2.99	6.50	7.88	9.63	2.63	1.25	5/8	1.13	3.31	2.00	0.19	3.13	17
QMP13J060S	60 mm	22213	69.9	147.3	91.9	174.8	219.2	260.4	73.7	35.1	16	31.5	91.2	54.1	5.3	85.6	10.0
QMP13J207S	2 7/16 in.		2.75	5.80	3.62	6.88	8.63	10.25	2.90	1.38	5/8	1.24	3.59	2.13	0.21	3.37	22
QMP13J208S	2 1/2 in.		69.9	147.3	91.9	174.8	219.2	260.4	73.7	35.1	16	31.5	91.2	54.1	5.3	85.6	10.0
			2.75	5.80	3.62	6.88	8.63	10.25	2.90	1.38	5/8	1.24	3.59	2.13	0.21	3.37	22
QMP13J065S	65 mm	22215	79.5	164.3	101.9	200.2	244.6	295.4	76.2	35.1	20	31.8	98.3	60.2	6.4	91.9	12.7
QMP15J211S	2 1/16 in.		3.13	6.47	4.01	7.88	9.63	11.63	3.00	1.38	3/4	1.25	3.87	2.37	0.25	3.62	28
QMP15J212S	2 3/4 in.		79.5	164.3	101.9	200.2	244.6	295.4	76.2	35.1	20	31.8	98.3	60.2	6.4	91.9	12.7
			3.13	6.47	4.01	7.88	9.63	11.63	3.00	1.38	3/4	1.25	3.87	2.37	0.25	3.62	28
QMP15J070S	70 mm	22218	95.3	195.3	120.9	238.3	285.8	342.9	86.6	47.8	24	36.6	109.2	65.8	7.1	102.4	20.4
QMP15J215S	2 15/16 in.		3.75	7.69	4.76	9.38	11.25	13.50	3.41	1.88	7/8	1.44	4.30	2.59	0.28	4.03	45
QMP15J300S	3 in.		95.3	195.3	120.9	238.3	285.8	342.9	86.6	47.8	24	36.6	109.2	65.8	7.1	102.4	20.4
			3.75	7.69	4.76	9.38	11.25	13.50	3.41	1.88	7/8	1.44	4.30	2.59	0.28	4.03	45
QMP15J075S	75 mm	22220	104.9	209.8	152.4	255.0	320.0	362.0	94.7	50.8	24	41.4	122.9	75.2	6.1	116.6	26.8
QMP18J303S	3 3/16 in.		4.13	8.26	6.00	10.04	12.60	14.25	3.73	2.00	1	1.63	4.84	2.96	0.24	4.59	59
QMP18J304S	3 1/4 in.		104.9	209.8	152.4	255.0	320.0	362.0	94.7	50.8	24	41.4	122.9	75.2	6.1	116.6	26.8
			4.13	8.26	6.00	10.04	12.60	14.25	3.73	2.00	1	1.63	4.84	2.96	0.24	4.59	59
QMP18J080S	80 mm	22220	104.9	209.8	152.4	255.0	320.0	362.0	94.7	50.8	24	41.4	122.9	75.2	6.1	116.6	26.8
QMP18J085S	85 mm		4.13	8.26	6.00	10.04	12.60	14.25	3.73	2.00	1	1.63	4.84	2.96	0.24	4.59	59
QMP18J307S	3 7/16 in.		104.9	209.8	152.4	255.0	320.0	362.0	94.7	50.8	24	41.4	122.9	75.2	6.1	116.6	26.8
			4.13	8.26	6.00	10.04	12.60	14.25	3.73	2.00	1	1.63	4.84	2.96	0.24	4.59	59
QMP18J308S	3 1/2 in.	22220	104.9	209.8	152.4	255.0	320.0	362.0	94.7	50.8	24	41.4	122.9	75.2	6.1	116.6	26.8
QMP18J090S	90 mm		4.13	8.26	6.00	10.04	12.60	14.25	3.73	2.00	1	1.63	4.84	2.96	0.24	4.59	59
QMP20J311S	3 1/16 in.		104.9	209.8	152.4	255.0	320.0	362.0	94.7	50.8	24	41.4	122.9	75.2	6.1	116.6	26.8
			4.13	8.26	6.00	10.04	12.60	14.25	3.73	2.00	1	1.63	4.84	2.96	0.24	4.59	59
QMP20J312S	3 3/8 in.	22220	104.9	209.8	152.4	255.0	320.0	362.0	94.7	50.8	24	41.4	122.9	75.2	6.1	116.6	26.8
QMP20J315S	3 1/16 in.		4.13	8.26	6.00	10.04	12.60	14.25	3.73	2.00	1	1.63	4.84	2.96	0.24	4.59	59
QMP20J400S	4 in.		104.9	209.8	152.4	255.0	320.0	362.0	94.7	50.8	24	41.4	122.9	75.2	6.1	116.6	26.8
			4.13	8.26	6.00	10.04	12.60	14.25	3.73	2.00	1	1.63	4.84	2.96	0.24	4.59	59
QMP20J100S	100 mm	22220	104.9	209.8	152.4	255.0	320.0	362.0	94.7	50.8	24	41.4	122.9	75.2	6.1	116.6	26.8
			4.13	8.26	6.00	10.04	12.60	14.25	3.73	2.00	1	1.63	4.84	2.96	0.24	4.59	59

QMPL TWO-BOLT PILLOW BLOCKS

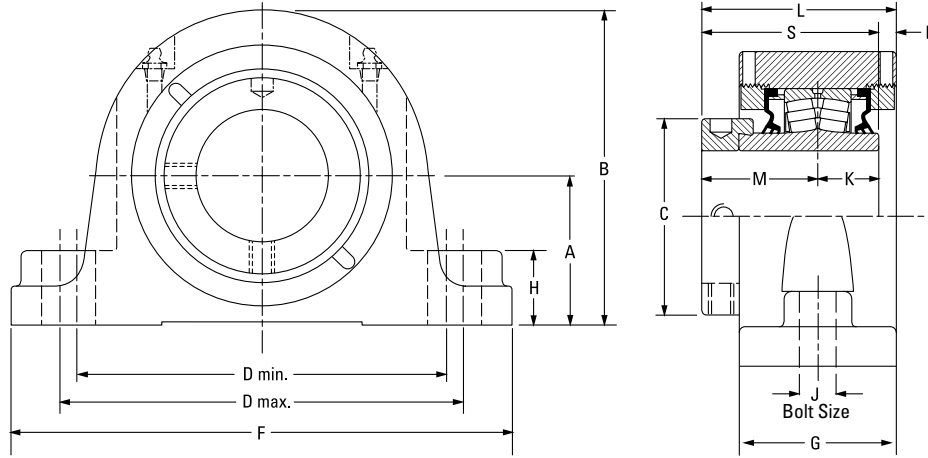

Bearing Part No.	Shaft Dia.	Bearing No.	A	B	C	D min.	D max.	F	G	H	J	K	L	M	R	S	Wt.
			mm in.	mm in.	mm in.	mm in.	mm in.	mm in.	mm in.	mm in.	mm in.	mm in.	mm in.	mm in.	mm in.	mm in.	mm in.
QMPL08J035S	35 mm	22208	47.8	94.7	60.5	119.1	152.4	174.8	57.2	25.4	12	25.4	73.2	44.5	3.3	69.9	4.1
QMPL08J107S	1 7/16 in.		1.88	3.73	2.38	4.69	6.00	6.88	2.25	1.00	1/2	1.00	2.88	1.75	0.13	2.75	9
QMPL08J108S	1 1/2 in.																
QMPL09J040S	40 mm	22209	54.1	104.9	66.5	133.4	146.1	181.1	60.2	31.8	12	25.4	77.7	47.8	4.8	73.2	4.5
QMPL09J111S	1 11/16 in.		2.13	4.13	2.62	5.25	5.75	7.13	2.37	1.25	1/2	1.00	3.06	1.88	0.19	2.88	10
QMPL09J112S	1 3/4 in.																
QMPL09J045S	45 mm	22210	57.2	122.2	71.4	150.6	161.5	212.9	62.0	31.8	16	25.4	79.0	47.5	6.1	72.9	5.9
QMPL10J115S	1 15/16 in.		2.25	4.81	2.81	5.93	6.36	8.38	2.44	1.25	3/8	1.00	3.11	1.87	0.24	2.87	13
QMPL10J200S	2 in.																
QMPL10J050S	50 mm	22211	63.5	133.4	75.9	165.1	179.3	225.6	65.5	31.8	16	28.4	83.3	50.8	4.3	79.2	7.7
QMPL11J203S	2 3/16 in.		2.50	5.25	2.99	6.50	7.06	8.88	2.58	1.25	3/8	1.12	3.28	2.00	0.17	3.12	17
QMPL11J204S	2 1/4 in.																
QMPL11J055S	55 mm	22213	69.9	147.3	91.9	173.0	189.0	235.0	73.7	35.1	16	31.5	90.9	54.1	5.3	85.6	10.0
QMPL13J060S	2 7/16 in.		2.75	5.80	3.62	6.81	7.44	9.25	2.90	1.38	3/8	1.24	3.58	2.13	0.21	3.37	22
QMPL13J207S	2 7/16 in.																
QMPL13J208S	2 1/2 in.																
QMPL13J065S	65 mm	22215	82.6	167.4	101.9	195.6	213.4	265.2	76.2	35.1	20	31.8	98.3	60.2	6.4	91.9	12.7
QMPL15J211S	2 11/16 in.		3.25	6.59	4.01	7.70	8.40	10.44	3.00	1.38	3/4	1.25	3.87	2.37	0.25	3.62	28
QMPL15J212S	2 3/4 in.																
QMPL15J070S	70 mm	22218	95.3	195.3	120.9	235.0	273.1	330.2	86.6	47.8	24	36.6	109.2	65.8	7.1	102.4	20.4
QMPL15J215S	2 15/16 in.		3.75	7.69	4.76	9.25	10.75	13.00	3.41	1.88	7/8	1.44	4.30	2.59	0.28	4.03	45
QMPL15J300S	3 in.																
QMPL15J075S	75 mm	22220	108.0	212.9	152.4	255.0	320.0	362.0	94.7	53.8	24	41.4	122.9	75.2	6.1	116.6	26.8
QMPL18J303S	3 3/16 in.		4.25	8.38	6.00	10.04	12.60	14.25	3.73	2.12	1	1.63	4.84	2.96	0.24	4.59	59
QMPL18J304S	3 1/4 in.																
QMPL18J080S	80 mm																
QMPL18J085S	85 mm																
QMPL18J307S	3 7/16 in.																
QMPL18J308S	3 1/2 in.																
QMPL18J090S	90 mm																
QMPL20J311S	3 11/16 in.																
QMPL20J312S	3 3/4 in.																
QMPL20J315S	3 15/16 in.																
QMPL20J400S	4 in.																
QMPL20J100S	100 mm																

QMPF FOUR-BOLT PILLOW BLOCKS

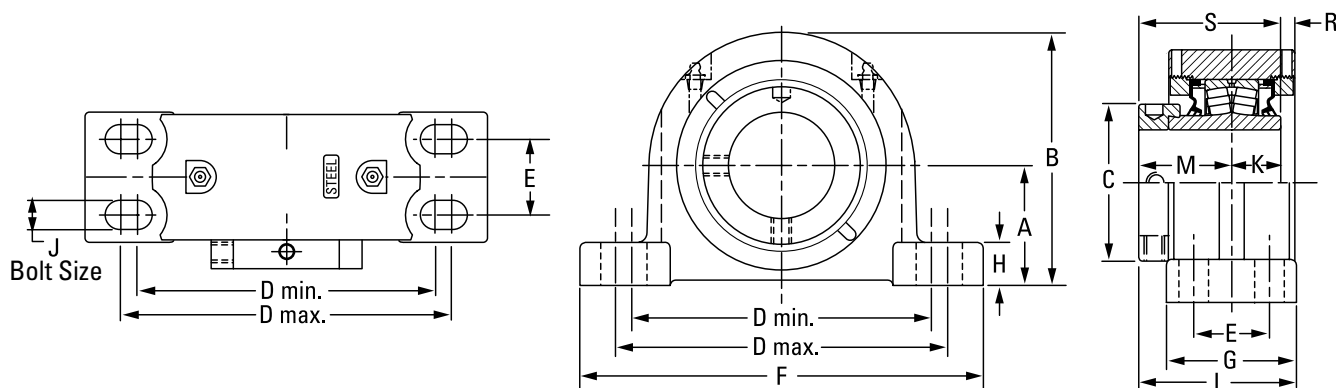

Bearing Part No.	Shaft Dia.	Bearing No.	A	B	C	D min.	D max.	E	F	G	H	J	K	L	M	R	S	Wt.
	mm in.		mm in.	mm in.	mm in.	mm in.	mm in.	mm in.	mm in.	mm in.	mm in.	mm in.	mm in.	mm in.	mm in.	mm in.	mm in.	kg lbs.
QMPF13J060S	60 mm	22213	69.9 2.75	147.3 5.80	91.9 3.62	174.8 6.88	193.8 7.63	44.5 1.75	235.0 9.25	76.2 3.00	24.9 0.98	16 5/8	31.5 1.24	92.2 3.63	54.1 2.13	5.3 0.21	85.6 3.37	9.1 20
QMPF13J207S	2 7/16 in.																	
QMPF13J208S	2 1/2 in.																	
QMPF13J065S	65 mm	22215	82.6 3.25	167.6 6.60	101.9 4.01	193.0 7.60	231.1 9.10	47.8 1.88	265.2 10.44	79.5 3.13	32.8 1.29	16 5/8	31.8 1.25	99.8 3.93	60.2 2.37	6.1 0.24	91.9 3.62	12.2 27
QMPF15J211S	2 1/16 in.																	
QMPF15J212S	2 3/4 in.																	
QMPF15J070S	70 mm	22218	95.3 3.75	195.3 7.69	120.9 4.76	225.6 8.88	276.4 10.88	50.8 2.00	312.4 12.30	95.3 3.75	39.6 1.56	20 3/4	36.6 1.44	113.3 4.46	65.8 2.59	8.1 0.32	102.4 4.03	22.2 49
QMPF15J215S	2 15/16 in.																	
QMPF15J300S	3 in.																	
QMPF15J075S	75 mm	22220	108.0 4.25	223.0 8.78	152.4 6.00	276.4 10.88	339.9 13.38	57.2 2.25	378.0 14.88	109.5 4.31	35.6 1.40	20 3/4	41.4 1.63	130.3 5.13	75.2 2.96	9.1 0.36	116.6 4.59	30.4 67
QMPF18J303S	3 3/16 in.																	
QMPF18J304S	3 1/4 in.																	
QMPF18J080S	80 mm	22222	120.7 4.75	233.4 9.19	160.0 6.30	301.8 11.88	368.3 14.50	63.5 2.50	409.7 16.13	120.7 4.75	40.1 1.58	20 3/4	46.5 1.83	154.4 6.08	94.0 3.70	4.3 0.17	140.5 5.53	37.2 82
QMPF18J085S	85 mm																	
QMPF18J307S	3 7/16 in.																	
QMPF18J308S	3 1/2 in.	22226	139.7 5.50	279.7 11.01	175.0 6.89	349.3 13.75	403.4 15.88	69.9 2.75	444.5 17.5	128.0 5.04	39.1 1.54	24 7/8	58.7 2.31	158.8 6.25	94.7 3.73	-0.8 -0.03	153.4 6.04	60.8 134
QMPF18J090S	90 mm																	
QMPF20J311S	3 11/16 in.																	
QMPF20J312S	3 3/4 in.	23230	169.9 6.69	330.2 13.00	205.0 8.07	441.5 17.38	485.9 19.13	95.3 3.75	558.8 22.00	171.5 6.75	76.2 3.00	24 1	75.9 2.99	201.7 7.94	116.1 4.57	6.6 0.26	192.0 7.56	113.4 250
QMPF20J315S	3 15/16 in.																	
QMPF20J400S	4 in.																	
QMPF20J100S	100 mm	23234	190.5 7.50	390.7 15.38	235.0 9.25	530.4 20.88	600.2 23.63	117.5 4.625	660.4 26.00	190.5 7.50	63.5 2.50	24 1	85.1 3.35	224.3 8.83	129.0 5.08	5.6 0.22	214.1 8.43	170.1 375
QMPF22J110S	110 mm																	
QMPF22J407S	4 7/16 in.																	
QMPF22J408S	4 1/2 in.	23234	190.5 7.50	390.7 15.38	235.0 9.25	530.4 20.88	600.2 23.63	117.5 4.625	660.4 26.00	190.5 7.50	63.5 2.50	24 1	85.1 3.35	224.3 8.83	129.0 5.08	5.6 0.22	214.1 8.43	170.1 375
QMPF22J115S	115 mm																	
QMPF26J125S	125 mm																	
QMPF26J415S	4 15/16 in.	23234	190.5 7.50	390.7 15.38	235.0 9.25	530.4 20.88	600.2 23.63	117.5 4.625	660.4 26.00	190.5 7.50	63.5 2.50	24 1	85.1 3.35	224.3 8.83	129.0 5.08	5.6 0.22	214.1 8.43	170.1 375
QMPF26J500S	5 in.																	
QMPF26J130S	130 mm																	
QMPF30J507S	5 7/16 in.	23234	190.5 7.50	390.7 15.38	235.0 9.25	530.4 20.88	600.2 23.63	117.5 4.625	660.4 26.00	190.5 7.50	63.5 2.50	24 1	85.1 3.35	224.3 8.83	129.0 5.08	5.6 0.22	214.1 8.43	170.1 375
QMPF30J508S	5 1/2 in.																	
QMPF30J140S	140 mm																	
QMPF30J155S	5 15/16 in.	23234	190.5 7.50	390.7 15.38	235.0 9.25	530.4 20.88	600.2 23.63	117.5 4.625	660.4 26.00	190.5 7.50	63.5 2.50	24 1	85.1 3.35	224.3 8.83	129.0 5.08	5.6 0.22	214.1 8.43	170.1 375
QMPF30J600S	6 in.																	
QMPF30J150S	150 mm																	
QMPF34J607S	6 7/16 in.	23234	190.5 7.50	390.7 15.38	235.0 9.25	530.4 20.88	600.2 23.63	117.5 4.625	660.4 26.00	190.5 7.50	63.5 2.50	24 1	85.1 3.35	224.3 8.83	129.0 5.08	5.6 0.22	214.1 8.43	170.1 375
QMPF34J608S	6 1/2 in.																	
QMPF34J170S	170 mm																	
QMPF34J615S	6 15/16 in.	23234	190.5 7.50	390.7 15.38	235.0 9.25	530.4 20.88	600.2 23.63	117.5 4.625	660.4 26.00	190.5 7.50	63.5 2.50	24 1	85.1 3.35	224.3 8.83	129.0 5.08	5.6 0.22	214.1 8.43	170.1 375
QMPF34J700S	7 in.																	
QMPF34J180S	180 mm																	

QMPR FOUR-BOLT PILLOW BLOCKS

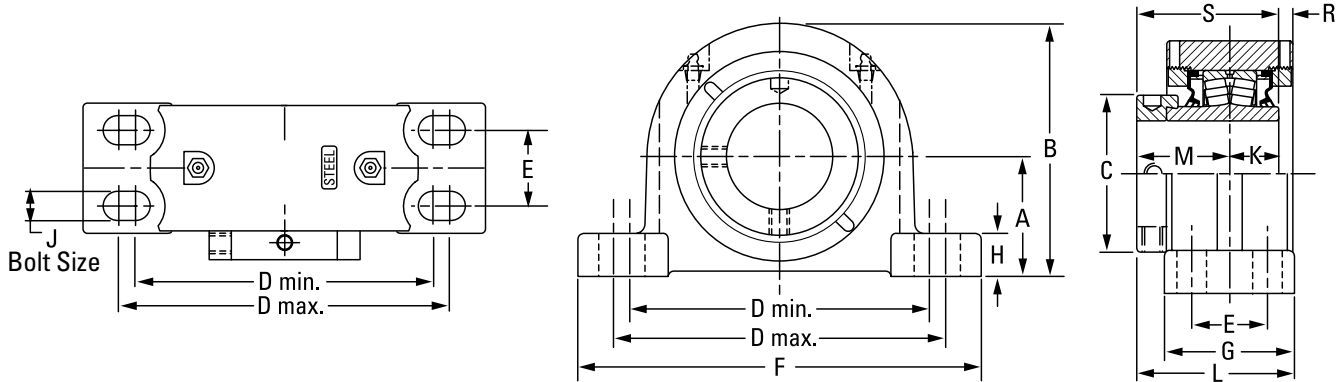

Bearing Part No.	Shaft Dia.	Bearing No.	A	B	C	D min.	D max.	E	F	G	H	J	K	L	M	R	S	Wt.	
	mm in.		mm in.	mm in.	mm in.	mm in.	mm in.	mm in.	mm in.	mm in.	mm in.	mm in.	mm in.	mm in.	mm in.	mm in.	mm in.	kg lbs.	
QMPR13J060S	60 mm	22213	69.9 2.75	147.3 5.80	91.9 3.62	181.1 7.13	222.3 8.75	47.8 1.88	260.4 10.25	82.6 3.25	24.9 0.98	16 5/8	31.5 1.24	95.5 3.76	54.1 2.13	5.3 0.21	85.6 3.37	9.1 20	
QMPR13J207S	2 7/16 in.																		
QMPR13J208S	2 1/2 in.																		
QMPR13J065S	65 mm	22215	79.5 3.13	164.3 6.47	101.9 4.01	203.2 8.00	243.8 9.60	54.1 2.13	275.1 10.83	85.9 3.38	29.5 1.16	16 5/8	31.8 1.25	103.1 4.06	60.2 2.37	6.1 0.24	91.9 3.62	12.2 27	
QMPR15J211S	2 11/16 in.																		
QMPR15J212S	2 3/4 in.																		
QMPR15J070S	70 mm	22218	95.3 3.75	195.3 7.69	120.9 4.76	235.0 9.25	285.8 11.25	60.5 2.38	346.2 13.63	95.3 3.75	39.6 1.56	20 3/4	36.6 1.44	113.3 4.46	65.8 2.59	8.1 0.32	102.4 4.03	22.2 49	
QMPR15J075S	75 mm																		
QMPR18J303S	3 3/16 in.																		
QMPR18J304S	3 1/4 in.																		
QMPR18J080S	80 mm																		
QMPR18J085S	85 mm																		
QMPR18J307S	3 7/16 in.																		
QMPR18J308S	3 1/2 in.																		
QMPR18J090S	90 mm																		

QMPH/QMPG FOUR-BOLT PILLOW BLOCKS

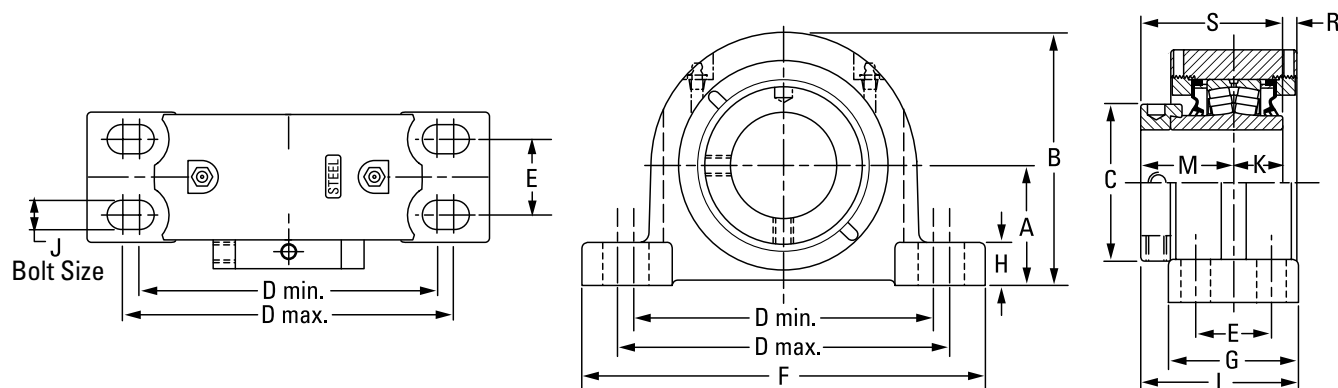

QMPH SAF STYLE FOUR-BOLT PILLOW BLOCK DIMENSIONS

Bearing Part No.	Shaft Dia.	Bearing No.	A	B	C	D min.	D max.	E	F	G	H	J	K	L	M	R	S	Wt.	
			mm in.	mm in.	mm in.	mm in.	mm in.	mm in.	mm in.	mm in.	mm in.	mm in.	mm in.	mm in.	mm in.	mm in.	mm in.	mm in.	mm in.
QMPH26J125S	125 mm	22226	152.4 6.00	290.8 11.45	175 6.89	406.4 16.00	435.1 17.13	85.9 3.38	500.4 19.70	128 5.04	51.8 2.04	24 1	58.7 2.31	158.5 6.24	94.5 3.72	-0.7 -0.03	153.4 6.04	60.8 134	
QMPH26J415S	4 1/16 in.																		
QMPH26J500S	5 in.																		
QMPH26J130S	130 mm	23230	169.9 6.69	330.7 13.02	205.0 8.07	441.5 17.38	485.9 19.13	95.3 3.75	558.8 22.00	171.5 6.75	76.2 3.00	24 1	75.9 2.99	199.1 7.84	116.1 4.57	5.1 0.20	192.0 7.56	118.8 262	
QMPH30J507S	5 7/16 in.																		
QMPH30J508S	5 1/2 in.																		
QMPH30J140S	140 mm	23230	179.4 7.06	339.9 13.38	205.0 8.07	492.3 19.38	549.4 21.63	108.0 4.25	628.7 24.75	171.5 6.75	85.9 3.38	24 1	75.9 2.99	201.7 7.94	116.1 4.57	6.6 0.26	192.0 7.56	122.9 271	
QMPH30J515S	5 15/16 in.																		
QMPH30J600S	6 in.																		
QMPH30J150S	150 mm	23234	190.5 7.50	390.7 15.38	235.0 9.25	530.4 20.88	600.2 23.63	117.5 4.63	711.2 28.00	190.5 7.50	63.5 2.50	24 1	85.1 3.35	224.3 8.83	129.0 5.08	5.6 0.22	214.1 8.43	170.1 375	
QMPH34J607S	6 7/16 in.																		
QMPH34J608S	6 1/2 in.																		
QMPH34J170S	170 mm	23234	200.0 7.88	400.1 15.75	235.0 9.25	549.4 21.63	619.3 24.38	112.7 4.44	711.2 28.00	190.5 7.50	73.2 2.88	30 1 1/4	85.1 3.35	224.3 8.83	129.0 5.08	5.6 0.22	214.1 8.43	178.3 393	
QMPH34J615S	6 15/16 in.																		
QMPH34J700S	7 in.																		
QMPH34J180S	180 mm																		

QMPG SN STYLE FOUR-BOLT PILLOW BLOCK DIMENSIONS

Bearing Part No.	Shaft Dia.	Bearing No.	A	B	C	D min.	D max.	E	F	G	H	J	K	L	M	R	S	Wt.	
			mm in.	mm in.	mm in.	mm in.	mm in.	mm in.	mm in.	mm in.	mm in.	mm in.	mm in.	mm in.	mm in.	mm in.	mm in.	mm in.	mm in.
QMPG26J125S	125 mm	22226	150.0 5.91	288.4 11.36	175.0 6.89	383.4 15.09	448.5 17.66	80.0 3.15	500.1 19.69	128 5.04	49.3 1.94	24 1	58.7 2.31	158.5 6.24	94.5 3.72	-6.9 -0.27	153.4 6.04	60.8 134	
QMPG26J415S	4 1/16 in.																		
QMPG26J500S	5 in.																		
QMPG26J130S	130 mm	23230	170.0 6.69	332.2 13.08	205.0 8.07	438.2 17.25	482.6 19.00	89.9 3.54	547.6 21.65	171.5 6.75	76.2 3.00	24 1	75.9 2.99	198.6 7.82	116.1 4.57	9.7 0.38	192.0 7.56	113.4 250	
QMPG30J507S	5 7/16 in.																		
QMPG30J508S	5 1/2 in.																		
QMPG30J140S	140 mm	23234	190.5 7.50	390.7 15.38	235.0 9.25	530.4 20.88	600.2 23.63	117.5 4.63	711.2 28.00	190.5 7.50	63.5 2.50	24 1	85.1 3.35	224.3 8.83	129.0 5.08	5.6 0.22	214.1 8.43	178.3 393	
QMPG30J515S	5 15/16 in.																		
QMPG30J600S	6 in.																		
QMPG30J150S	150 mm	23234	200.0 7.88	400.1 15.75	235.0 9.25	549.4 21.63	619.3 24.38	114.3 4.50	711.2 28.00	190.5 7.50	73.2 2.88	30 1 1/4	85.1 3.35	224.3 8.83	129.0 5.08	5.6 0.22	214.1 8.43	170.1 375	
QMPG34J607S	6 7/16 in.																		
QMPG34J608S	6 1/2 in.																		
QMPG34J170S	170 mm																		
QMPG34J615S	6 15/16 in.																		
QMPG34J700S	7 in.																		
QMPG34J180S	180 mm																		

OMPX 5000 SERIES FOUR-BOLT PILLOW BLOCKS

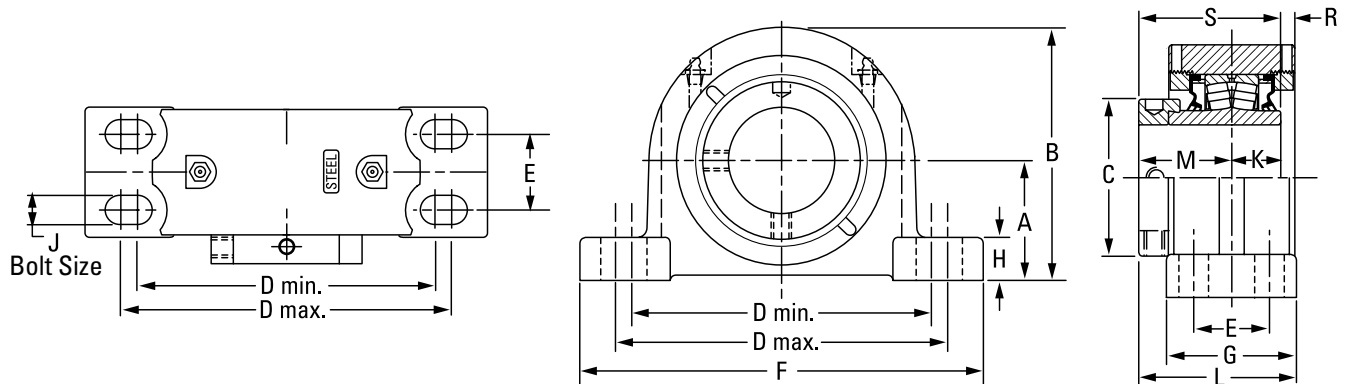

Bearing Part No.	Shaft Dia.	Bearing No.	A	B	C	D min.	D max.	E	F	G	H	J	K	L	M	R	S	Wt.
			mm in.	mm in.	mm in.	mm in.	mm in.	mm in.	mm in.	mm in.	mm in.	mm in.	mm in.	mm in.	mm in.	mm in.	mm in.	mm in.
QMPX13J060S	60 mm	22213	76.2 3.00	153.7 6.05	91.9 3.62	176.3 6.94	242.8 9.56	66.8 2.63	285.8 11.25	98.6 3.88	31.2 1.23	16 5/8	31.5 1.24	103.4 4.07	54.1 2.13	5.3 0.21	85.6 3.37	10.4 23
QMPX13J207S	2 7/8 in.																	
QMPX13J208S	2 1/2 in.																	
QMPX13J065S	65 mm	22215	88.9 3.50	173.5 6.83	101.9 4.01	230.1 9.06	265.2 10.44	68.9 2.75	330.2 13.00	108.0 4.25	39.1 1.54	20 3/4	31.8 1.25	114.3 4.50	60.2 2.37	7.1 0.28	91.9 3.62	12.7 28
QMPX15J211S	2 1/8 in.																	
QMPX15J212S	2 3/4 in.																	
QMPX15J070S	70 mm	22218	101.6 4.00	201.2 7.92	120.9 4.76	274.6 10.81	309.6 12.19	76.2 3.00	381.0 15.00	120.7 4.75	38.1 1.50	20 3/4	36.6 1.44	126.0 4.96	65.8 2.59	8.1 0.32	102.4 4.03	22.2 49
QMPX18J303S	3 3/8 in.																	
QMPX18J304S	3 1/4 in.																	
QMPX18J080S	80 mm	22220	127.0 5.00	239.8 9.44	152.4 6.00	317.5 12.50	355.6 14.00	88.9 3.50	425.5 16.75	139.7 5.50	41.4 1.63	24 7/8	41.4 1.63	145.3 5.72	75.2 2.96	8.6 0.34	116.6 4.59	30.4 67
QMPX18J085S	85 mm																	
QMPX18J307S	3 7/8 in.																	
QMPX18J308S	3 1/2 in.	22222	146.1 5.75	273.8 10.78	160.0 6.30	354.1 13.94	395.2 15.56	101.6 4.00	469.9 18.50	158.8 6.25	45.7 1.80	24 1	46.5 1.83	171.2 6.74	94.0 3.70	2.3 0.09	140.5 5.53	37.2 82
QMPX20J311S	3 1/8 in.																	
QMPX20J312S	3 3/4 in.																	
QMPX20J315S	3 15/16 in.	22222	146.1 5.75	273.8 10.78	160.0 6.30	354.1 13.94	395.2 15.56	101.6 4.00	469.9 18.50	158.8 6.25	45.7 1.80	24 1	46.5 1.83	171.2 6.74	94.0 3.70	2.3 0.09	140.5 5.53	37.2 82
QMPX20J400S	4 in.																	
QMPX20J100S	100 mm																	
QMPX22J110S	110 mm	22222	146.1 5.75	273.8 10.78	160.0 6.30	354.1 13.94	395.2 15.56	101.6 4.00	469.9 18.50	158.8 6.25	45.7 1.80	24 1	46.5 1.83	171.2 6.74	94.0 3.70	2.3 0.09	140.5 5.53	37.2 82
QMPX22J407S	4 7/8 in.																	
QMPX22J408S	4 1/2 in.																	
QMPX22J115S	115 mm	22222	146.1 5.75	273.8 10.78	160.0 6.30	354.1 13.94	395.2 15.56	101.6 4.00	469.9 18.50	158.8 6.25	45.7 1.80	24 1	46.5 1.83	171.2 6.74	94.0 3.70	2.3 0.09	140.5 5.53	37.2 82
QMPX22J110S	110 mm																	
QMPX22J407S	4 7/8 in.																	

⁽¹⁾No gussets on outside housing.

Continued on next page.

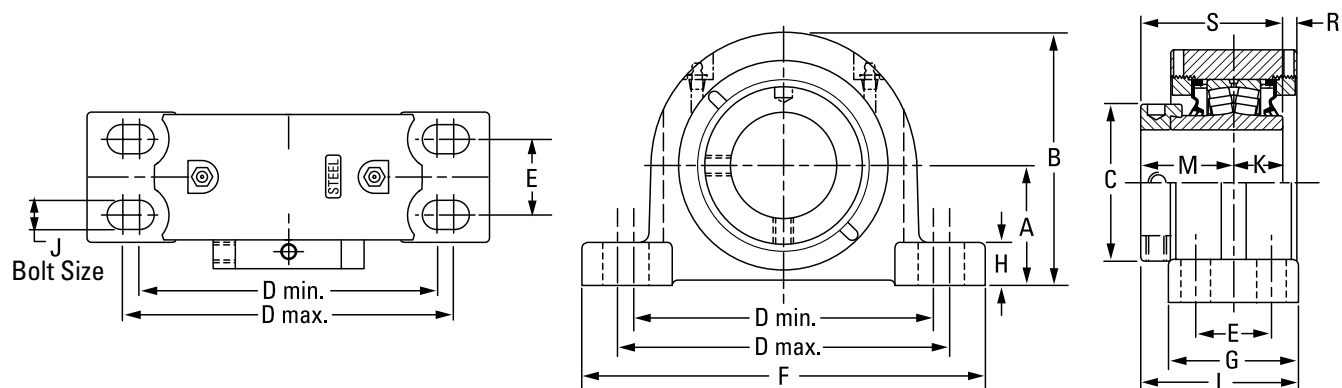

Continued from previous page.

Bearing Part No.	Shaft Dia.	Bearing No.	A	B	C	D min.	D max.	E	F	G	H	J	K	L	M	R	S	Wt.
	mm in.		mm in.	mm in.	mm in.	mm in.	mm in.	mm in.	mm in.	mm in.	mm in.	mm in.	mm in.	mm in.	mm in.	mm in.	mm in.	kg lbs.
QMPX26J125S	125 mm	22226	155.6 6.13	283.2 11.15	175.0 6.89	387.4 15.25	425.5 16.75	108.0 4.25	514.4 20.25	171.5 6.75	50.8 2.00	24 1 1/8	58.7 2.31	180.3 7.10	94.5 3.72	-1.5 -0.06	153.4 6.04	60.8 134
QMPX26J415S	4 15/16 in.																	
QMPX26J500S	5 in.																	
QMPX26J130S	130 mm	23230	169.9 6.69	330.2 13.00	205.0 8.07	439.9 17.32	485.8 19.125	93.5 3.68	558.8 22.00	171.5 6.75	76.2 3.00	24 1 1/8	75.9 2.99	201.7 7.94	116.1 4.57	6.6 0.26	192.0 7.56	113.4 250
QMPX30J507S	5 7/8 in.																	
QMPX30J508S	5 1/2 in.																	
QMPX30J140S	140 mm	23230	179.4 7.06	339.9 13.38	205.0 8.07	489.0 19.25	552.5 21.75	106.4 4.19	625.7 24.75	171.5 6.75	85.6 3.37	24 1 1/8	75.9 2.99	196.9 7.75	116.1 4.57	4.8 0.19	192.0 7.56	120.2 265
QMPX30J515S ⁽¹⁾	5 15/16 in.																	
QMPX30J600S ⁽¹⁾	6 in.																	
QMPX30J150S ⁽¹⁾	150 mm	23234	200.0 7.88	400.1 15.75	235.0 9.25	549.4 21.63	619.3 24.38	112.8 4.44	711.2 28.00	190.5 7.50	73.2 2.88	30 1 1/4	80.1 3.35	224.3 8.83	129.0 5.08	5.6 0.22	214.1 8.43	179.2 395
QMPX34J607S ⁽¹⁾	6 7/8 in.																	
QMPX34J608S ⁽¹⁾	6 1/2 in.																	
QMPX34J170S ⁽¹⁾	170 mm																	
QMPX34J615S ⁽¹⁾	6 15/16 in.																	
QMPX34J700S ⁽¹⁾	7 in.																	
QMPX34J180S ⁽¹⁾	180 mm																	

⁽¹⁾No gussets on outside housing.

QMPXT 5000 SERIES TWO-BOLT PILLOW BLOCKS

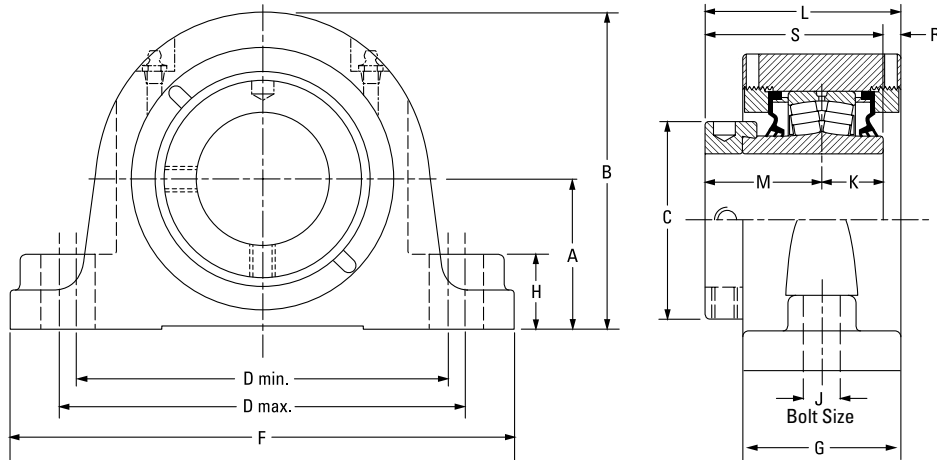

Bearing Part No.	Shaft Dia.	Bearing No.	A	B	C	D min.	D max.	F	G	H	J	K	L	M	R	S	Wt.
	mm in.		mm in.	mm in.	mm in.	mm in.	mm in.	mm in.	mm in.	mm in.	mm in.	mm in.	mm in.	mm in.	mm in.	mm in.	kg lbs.
QMPXT13J060S	60 mm	22213	76.2 3.00	153.7 6.05	91.9 3.62	194.6 7.66	223.0 8.78	285.8 11.25	73.7 2.90	35.1 1.38	20 3/4	31.5 1.24	91.4 3.60	54.1 2.13	5.3 0.21	85.6 3.37	10.0 22
QMPXT13J207S	2 7/16 in.																
QMPXT13J208S	2 1/2 in.																
QMPXT13J065S	65 mm																
QMPXT15J211S	2 1/16 in.	22215	88.9 3.50	173.7 6.84	101.9 4.01	230.1 9.06	265.2 10.44	330.2 13.00	75.7 2.98	35.1 1.38	24 7/8	31.8 1.25	98.0 3.86	60.2 2.37	6.1 0.24	91.9 3.62	12.7 28
QMPXT15J212S	2 3/4 in.																
QMPXT15J070S	70 mm																
QMPXT15J215S	2 15/16 in.																
QMPXT15J300S	3 in.																
QMPXT15J075S	75 mm																

QMSN SN-STYLE TWO-BOLT PILLOW BLOCKS – PURE METRIC DESIGN

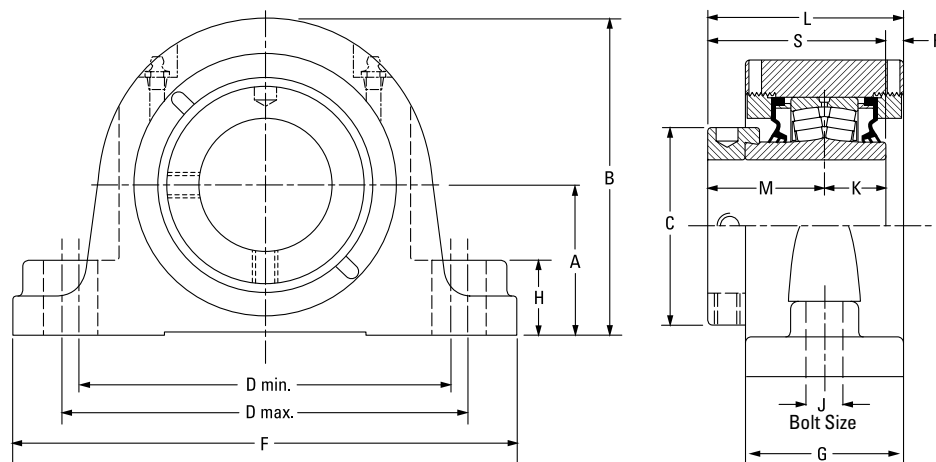

Bearing Part No.	Shaft Dia.	Bearing No.	A	B	C	D min.	D max.	F	G	H	J	K	L	M	R	S	Wt.
			mm in.	mm in.	mm in.	mm in.	mm in.	mm in.	mm in.	mm in.	mm in.	mm in.	mm in.	mm in.	mm in.	mm in.	mm in.
QMSN08J035S	35 mm	22208	60	111	60.5	159	175	205	62	35	12	25	75	44	5	70	10.5
QMSN08J107S	1 7/16 in.		2.36	4.37	2.38	6.26	6.89	8.07	2.44	1.38	1/2	1.00	2.95	1.75	0.20	2.75	23
QMSN08J108S	1 1/2 in.																
QMSN09J040S	40 mm	22209	60	111	67	159	175	205	62	35	12	25	79	48	6	73	10.5
QMSN09J111S	1 7/16 in.		2.36	4.37	2.64	6.26	6.89	8.07	2.44	1.38	1/2	0.98	3.11	1.89	0.24	2.87	23
QMSN09J112S	1 3/4 in.																
QMSN09J045S	45 mm	22210	70	136	70	183	216	254	68	25	16	25	82	48	9	73	12.7
QMSN10J115S	1 7/16 in.		2.76	5.35	2.76	7.20	8.50	10.00	2.68	0.98	5/8	0.98	3.23	1.89	0.35	2.87	28
QMSN10J200S	2 in.																
QMSN10J050S	50 mm	22211	70	141	76	183	216	254	68	25	16	29	85	51	6	80	13.2
QMSN11J203S	2 3/16 in.		2.76	5.55	2.99	7.20	8.50	10.00	2.68	0.98	5/8	1.14	3.35	2.01	0.24	3.15	29
QMSN11J204S	2 1/4 in.																
QMSN11J055S	55 mm	22213	80	157	92	196	235	275	74	35	16	31	91	55	5	86	15.9
QMSN13J060S	2 1/8 in.		3.15	6.18	3.62	7.72	9.25	10.83	2.91	1.38	5/8	1.22	3.58	2.17	0.20	3.39	35
QMSN13J207S	2 7/16 in.																
QMSN13J208S	2 1/2 in.	22215	95	183	102	241	279	316	76	34	20	32	98	60	6	92	20.9
QMSN13J065S	2 5/16 in.		3.74	7.20	4.02	9.49	10.98	12.44	2.99	1.34	3/4	1.26	3.86	2.36	0.24	3.62	46
QMSN15J211S	2 3/8 in.																
QMSN15J070S	70 mm	22218	100	200	121	279	292	345	86	39	20	37	109	66	7	103	25.5
QMSN15J215S	2 7/16 in.		3.94	7.87	4.76	10.98	11.50	13.58	3.39	1.54	3/4	1.46	4.29	2.60	0.28	4.06	56
QMSN15J300S	3 in.																
QMSN15J075S	75 mm																
QMSN18J303S	3 3/16 in.																
QMSN18J304S	3 1/4 in.																
QMSN18J080S	80 mm																

Continued on next page.

QMSN SN-STYLE TWO-BOLT PILLOW BLOCKS – PURE METRIC DESIGN – continued

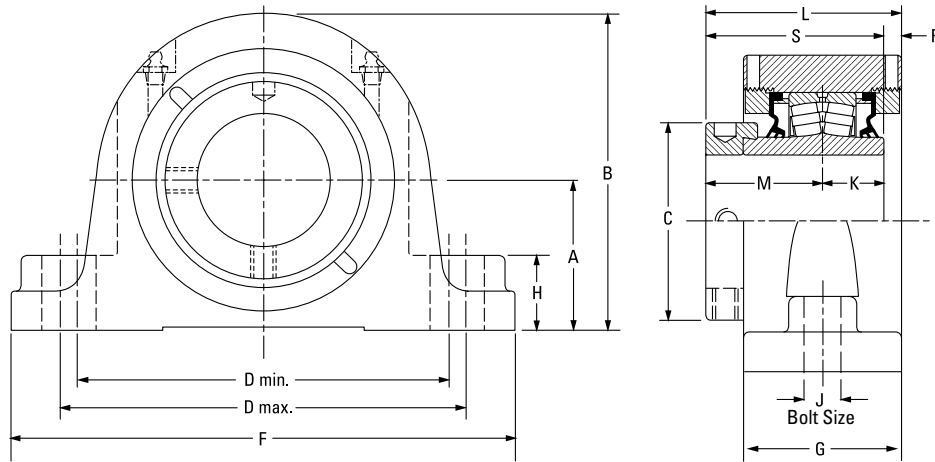

Continued from previous page.

Bearing Part No.	Shaft Dia.	Bearing No.	A	B	C	D min.	D max.	F	G	H	J	K	L	M	R	S	Wt.
	mm in.		mm in.	mm in.	mm in.	mm in.	mm in.	mm in.	mm in.	mm in.	mm in.	mm in.	mm in.	mm in.	mm in.	mm in.	kg lbs.
QMSN18J085S	85 mm	22218	112 4.41	212 8.35	121 4.76	280 11.02	292 11.50	345 13.58	86 3.38	39 1.53	20 3/4	37 1.46	109 4.29	66 2.60	7 0.28	103 4.06	25.5 56
QMSN18J307S	3 7/16 in.	22218	112 4.41	212 8.35	121 4.76	290 11.42	327 12.87	380 14.96	86 3.38	39 1.53	24 7/8	37 1.46	109 4.29	66 2.60	7 0.28	103 4.06	25.5 56
QMSN18J308S	3 1/2 in.																
QMSN18J090S	90 mm																
QMSN20J311S	3 11/16 in.	22220	125 4.92	241 9.48	152 5.98	319 12.58	366 14.42	410 16.14	101 3.96	50 1.98	24 7/8	41 1.61	126 4.96	75 2.95	9 0.35	116 4.57	35.9 79
QMSN20J312S	3 3/4 in.																
QMSN20J315S	3 15/16 in.																
QMSN20J400S	4 in.																
QMSN20J100S	100 mm																
QMSN22J110S	110 mm	22222	140 5.51	255 10.04	160 6.30	332 13.08	365 14.37	410 16.14	105 4.15	39 1.53	24 7/8	47 1.85	147 5.79	94 3.70	6 0.24	141 5.55	35.9 79
QMSN22J407S	4 7/16 in.	22222	150 5.91	265 10.43	160 6.30	367 14.45	400 15.75	445 17.52	105 4.13	49 1.93	24 7/8	47 1.85	147 5.79	94 3.70	6 0.24	141 5.55	35.5 78
QMSN22J408S	4 1/2 in.																
QMSN22J115S	115 mm																
QMSN26J125S	125 mm	22226	150 5.91	282 11.10	175 6.89	402 15.83	435 17.13	500 19.69	113 4.45	49 1.93	30 1 1/4	58 2.28	151 5.94	95 3.74	2 0.08	153 6.02	40.0 88
QMSN26J415S	4 15/16 in.																
QMSN26J500S	5 in.																
QMSN26J130S	130 mm																
QMSN30J507S	5 7/16 in.	23230	170 6.69	330 13.01	205 8.07	461 18.15	479 18.86	550 21.65	171 6.75	76 3.01	30 1 1/4	76 2.99	202 7.94	116 4.57	7 0.26	192 7.56	136.4 300
QMSN30J508S	5 1/2 in.																
QMSN30J140S	140 mm																
QMSN30J515S	5 15/16 in.																
QMSN30J600S	6 in.																
QMSN30J150S	150 mm																

QMC PILOTED FLANGE CARTRIDGES

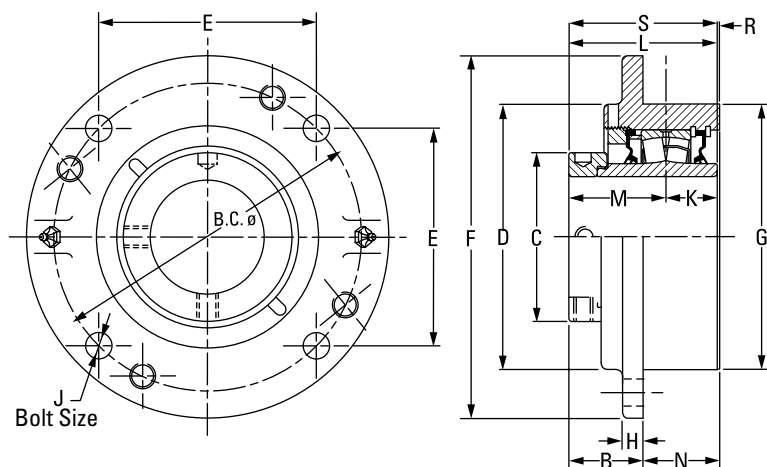

Bearing Part No.	Shaft Dia.	Bearing No.	B FIX	B EXP	B.C.	C	D	E	F	G ⁽¹⁾	H	J	K	L FIX	L EXP	M	N	R	S	Wt.
			mm in.	mm in.	mm in.	mm in.	mm in.	mm in.	mm in.	mm in.	mm in.	mm in.	mm in.	mm in.	mm in.	mm in.	mm in.	mm in.	mm in.	mm in.
QMC08J035S	35 mm	22208	49.8	51.8	111.3	60.5	92.2	78.5	133.4	92.1	12.7	10	25.4	73.7	75.7	44.5	23.9	3.81	69.9	3.6
QMC08J107S	1 7/16 in.		1.96	2.04	4.38	2.38	3.63	3.09	5.25	3.625	0.50	7/16	1.00	2.90	2.98	1.75	0.94	0.15	2.75	8
QMC08J108S	1 1/2 in.																			
QMC09J040S	40 mm	22209	54.6	56.6	130.3	66.8	111.3	91.9	155.7	108.0	12.7	10	25.4	77.0	79.0	47.5	22.4	3.81	72.9	4.1
QMC09J111S	1 11/16 in.		2.15	2.23	5.13	2.63	4.38	3.62	6.13	4.250	0.50	7/16	1.00	3.03	3.11	1.87	0.88	0.15	2.87	9
QMC09J112S	1 3/4 in.																			
QMC09J045S	45 mm	22210	50.4	52.6	136.7	70.1	113.5	96.5	162.1	114.3	16.0	10	25.4	77.5	79.5	47.5	26.9	4.6	72.9	4.5
QMC10J115S	1 5/8 in.		1.99	2.07	5.38	2.76	4.47	3.80	6.38	4.500	0.63	7/16	1.00	3.05	3.13	1.87	1.06	0.18	2.87	10
QMC10J200S	2 in.																			
QMC10J050S	50 mm	22211	54.4	56.4	152.4	75.9	127.0	107.7	185.4	127.0	14.7	12	28.7	83.1	85.1	50.5	28.7	3.6	79.2	5.9
QMC11J203S	2 3/8 in.		2.14	2.22	6.00	2.99	5.00	4.24	7.30	5.000	0.58	1/2	1.13	3.27	3.35	1.99	1.13	0.14	3.12	13
QMC11J204S	2 1/4 in.																			
QMC11J055S	55 mm	22213	59.4	61.5	165.1	91.9	139.7	116.8	193.8	139.7	17.5	12	31.5	87.9	91.2	54.1	28.7	2.3	85.6	7.3
QMC13J060S	60 mm		2.34	2.42	6.50	3.62	5.50	4.60	7.63	5.500	0.69	1/2	1.24	3.46	3.59	2.13	1.13	0.09	3.37	16
QMC13J207S	2 7/16 in.																			
QMC13J208S	2 1/2 in.																			
QMC13J065S	65 mm	22215	62.5	64.5	190.5	101.9	159.2	134.6	222.3	161.9	20.6	16	31.8	94.5	96.5	60.2	31.8	2.3	91.9	10.0
QMC15J211S	2 11/16 in.		2.46	2.54	7.50	4.01	6.27	5.30	8.75	6.375	0.81	5/8	1.25	3.72	3.80	2.37	1.25	0.09	3.62	22
QMC15J212S	2 3/4 in.																			
QMC15J070S	70 mm	22218	73.2	75.2	219.2	120.9	187.5	154.9	262.6	187.3	25.4	20	36.6	106.4	108.5	65.8	33.3	4.1	116.6	14.5
QMC15J300S	3 in.		2.88	2.96	8.63	4.76	7.38	6.10	10.34	7.375	1.00	3/4	1.44	4.19	4.27	2.59	1.31	0.16	4.59	32
QMC15J075S	75 mm																			
QMC18J303S	3 3/8 in.																			
QMC18J304S	3 1/4 in.																			
QMC18J080S	80 mm	22220	72.1	74.2	238.3	152.4	206.5	168.4	276.4	206.4	25.4	20	41.4	126.0	128.0	75.2	54.1	9.4	116.6	19.5
QMC18J085S	85 mm		2.84	2.92	9.38	6.00	8.13	6.63	10.88	8.125	1.00	3/4	1.63	4.96	5.04	2.96	2.13	0.37	4.59	43
QMC18J307S	3 7/16 in.																			
QMC18J308S	3 1/2 in.																			
QMC18J090S	90 mm	22222	92.5	94.5	298.5	160.0	254.0	149.4	342.9	260.4	25.4	20	46.5	140.7	142.7	94.0	48.3	0.3	140.5	32.7
QMC20J311S	3 11/16 in.		3.64	3.72	11.75 ⁽²⁾	6.30	10.00	5.88 ⁽²⁾	13.50	10.250	1.00	3/4 ⁽²⁾	1.83	5.54	5.62	3.70	1.90	0.01	5.53	72
QMC20J312S	3 3/4 in.																			
QMC20J315S	3 15/16 in.																			
QMC20J400S	4 in.																			
QMC20J100S	100 mm																			
QMC22J110S ⁽²⁾	110 mm																			
QMC22J407S ⁽²⁾	4 7/16 in.																			
QMC22J408S ⁽²⁾	4 1/2 in.																			
QMC22J115S ⁽²⁾	115 mm																			

⁽¹⁾Pilot tolerance: +0/-0.05 mm (+0/-0.002 in.).

⁽²⁾Six-bolt housing.

QMCW PILOTED FLANGE CARTRIDGES

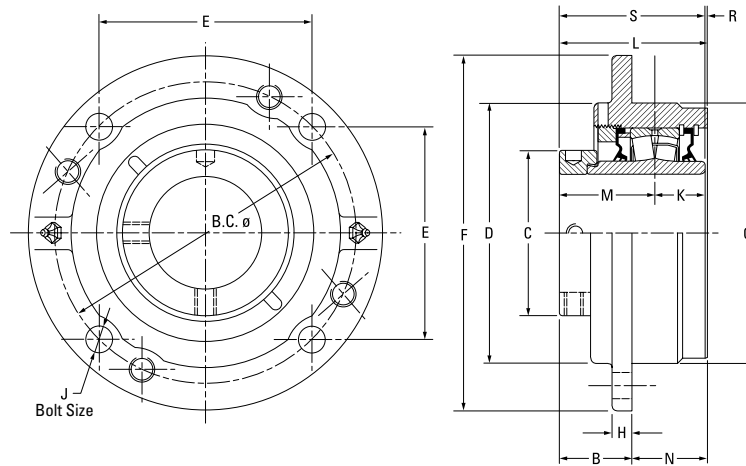

Bearing Part No.	Shaft Dia.	Bearing No.	B FIX	B EXP	B.C.	C	D	E	F	G ⁽¹⁾	H	J	K	L FIX	L EXP	M	N	R	S	Wt.	
	mm in.		mm in.	mm in.	mm in.	mm in.	mm in.	mm in.	mm in.	mm in.	mm in.	mm in.	mm in.	mm in.	mm in.	mm in.	mm in.	mm in.	mm in.	mm in.	kg lbs.
QMCW08J035S	35 mm	22208	38.6	40.9	111.3	59.9	92.2	78.5	133.4	92.1	12.7	10	25.4	73.7	75.7	44.5	35.1	3.8	69.9	3.6	
QMCW08J107S	1 7/16 in.		1.53	1.61	4.38	2.36	3.63	3.09	5.25	3.625	0.50	7/16	1.00	2.90	2.98	1.75	1.38	0.15	2.75	8	
QMCW08J108S	1 1/2 in.																				
QMCW09J040S	40 mm	22209	38.9	40.1	130.3	66.8	111.3	91.9	155.7	108.0	10.2	10	25.1	77.0	78.2	47.8	38.1	4.1	72.9	4.1	
QMCW09J111S	1 11/16 in.		1.53	1.58	5.13	2.63	4.38	3.62	6.13	4.250	0.40	7/16	0.99	3.03	3.08	1.88	1.50	0.16	2.87	9	
QMCW09J112S	1 3/4 in.																				
QMCW09J045S	45 mm	22210	39.1	41.1	136.7	71.4	113.5	96.5	162.1	114.3	9.7	10	24.9	77.2	79.2	48.0	38.1	4.3	72.9	4.5	
QMCW10J115S	1 15/16 in.		1.54	1.62	5.38	2.81	4.47	3.80	6.38	4.500	0.38	7/16	0.98	3.04	3.12	1.89	1.50	0.17	2.87	10	
QMCW10J200S	2 in.																				
QMCW10J050S	50 mm	22211	45.7	47.8	152.4	75.9	127.0	107.7	181.1	127.0	14.2	12	28.7	86.9	88.9	50.5	41.4	7.62	79.2	5.9	
QMCW11J203S	2 3/16 in.		1.80	1.88	6.00	2.99	5.00	4.24	7.13	5.000	0.56	1/2	1.13	3.42	3.50	1.99	1.63	0.30	3.12	13	
QMCW11J204S	2 1/4 in.																				
QMCW11J055S	55 mm	22213	47.5	49.5	165.1	91.9	139.7	116.8	193.8	139.7	12.7	12	31.5	90.2	92.2	54.1	42.9	4.31	85.6	7.3	
QMCW13J060S	60 mm		1.87	1.95	6.50	3.62	5.50	4.60	7.63	5.500	0.50	1/2	1.24	3.55	3.63	2.13	1.69	0.17	3.37	16	
QMCW13J207S	2 7/16 in.																				
QMCW13J208S	2 1/2 in.	22215	46.0	48.0	190.5	101.9	162.1	134.6	222.3	161.9	12.7	16	31.8	93.5	95.5	60.2	47.8	1.5	91.9	10.0	
QMCW13J065S	65 mm		1.81	1.89	7.50	4.01	6.38	5.30	8.75	6.375	0.50	5/8	1.25	3.68	3.76	2.37	1.88	0.06	3.62	22	
QMCW15J211S	2 11/16 in.																				
QMCW15J212S	2 3/4 in.	22218	62.5	64.5	219.2	120.9	187.5	154.9	260.4	187.3	22.4	20	36.6	110.2	112.3	65.8	47.8	7.9	102.4	14.5	
QMCW15J070S	70 mm		2.46	2.54	8.63	4.76	7.38	6.10	10.25	7.375	0.88	3/4	1.44	4.34	4.42	2.59	1.88	0.31	4.03	32	
QMCW15J215S	2 15/16 in.																				
QMCW15J300S	3 in.	22218	62.5	64.5	219.2	120.9	187.5	154.9	260.4	187.3	22.4	20	36.6	110.2	112.3	65.8	47.8	7.9	102.4	14.5	
QMCW15J075S	75 mm		2.46	2.54	8.63	4.76	7.38	6.10	10.25	7.375	0.88	3/4	1.44	4.34	4.42	2.59	1.88	0.31	4.03	32	
QMCW18J303S	3 3/16 in.																				
QMCW18J304S	3 1/4 in.	22218	62.5	64.5	219.2	120.9	187.5	154.9	260.4	187.3	22.4	20	36.6	110.2	112.3	65.8	47.8	7.9	102.4	14.5	
QMCW18J080S	80 mm		2.46	2.54	8.63	4.76	7.38	6.10	10.25	7.375	0.88	3/4	1.44	4.34	4.42	2.59	1.88	0.31	4.03	32	
QMCW18J085S	85 mm																				
QMCW18J307S	3 7/16 in.	22218	62.5	64.5	219.2	120.9	187.5	154.9	260.4	187.3	22.4	20	36.6	110.2	112.3	65.8	47.8	7.9	102.4	14.5	
QMCW18J307S	3 7/16 in.		2.46	2.54	8.63	4.76	7.38	6.10	10.25	7.375	0.88	3/4	1.44	4.34	4.42	2.59	1.88	0.31	4.03	32	
QMCW18J308S	3 1/2 in.																				
QMCW18J090S	90 mm																				

⁽¹⁾Pilot tolerance: +0/-0.05 mm (+0/-0.002 in.).

Continued on next page.

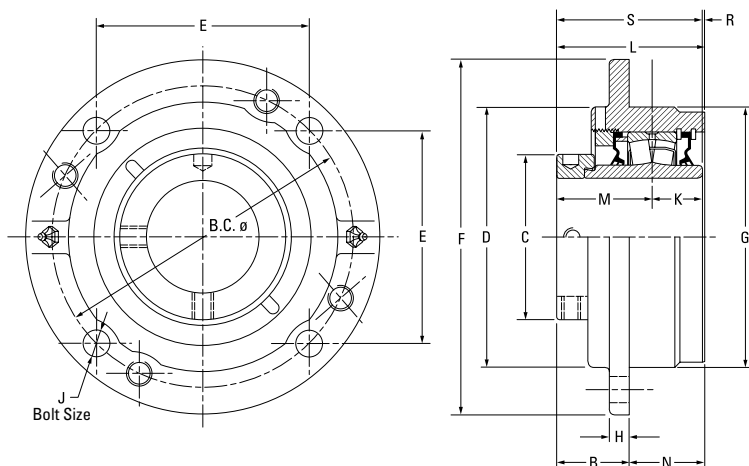

Continued from previous page.

Bearing Part No.	Shaft Dia.	Bearing No.	B FIX	B EXP	B.C.	C	D	E	F	G ⁽¹⁾	H	J	K	L FIX	L EXP	M	N	R	S	Wt.
			mm in.	mm in.	mm in.	mm in.	mm in.	mm in.	mm in.	mm in.	mm in.	mm in.	mm in.	mm in.	mm in.	mm in.	mm in.	mm in.	mm in.	mm in.
QMCW20J311S	3 1/16 in.	22220	63.5 2.50	65.5 2.58	238.3 9.38	152.4 6.00	206.5 8.13	168.4 6.63	276.4 10.88	206.4 8.125	25.4 1.00	20 3/4	41.4 1.63	120.7 4.75	122.7 4.83	75.2 2.96	57.2 2.25	4.1 0.16	116.6 4.59	19.5 43
QMCW20J312S	3 3/4 in.																			
QMCW20J315S	3 15/16 in.																			
QMCW20J400S	4 in.																			
QMCW20J100S	100 mm	22222	76.5 3.01	78.5 3.09	298.5 11.75 ⁽²⁾	160.0 6.30	254.0 10.00	149.4 5.88 ⁽²⁾	342.9 13.50	260.4 10.250	25.4 1.00	20 3/4 ⁽²⁾	46.5 1.83	144.8 5.70	146.8 5.78	94.0 3.70	68.3 2.69	4.3 0.17	140.5 5.53	32.7 72
QMCW22J110S ⁽²⁾	110 mm																			
QMCW22J407S ⁽²⁾	4 7/16 in.																			
QMCW22J408S ⁽²⁾	4 1/2 in.																			
QMCW22J115S ⁽²⁾	115 mm	22226	73.7 2.90	75.7 2.98	323.9 12.75 ⁽²⁾	175.0 6.89	266.7 10.50	162.1 6.38 ⁽²⁾	374.7 14.75	279.4 11.000	26.2 1.03	24 7/8 ⁽²⁾	58.7 2.31	151.4 5.96	153.4 6.04	94.7 3.73	77.9 3.065	-1.8 -0.07	153.4 6.04	46.3 102
QMCW26J415S ⁽²⁾	4 15/16 in.																			
QMCW26J500S ⁽²⁾	5 in.																			
QMCW26J130S ⁽²⁾	130 mm																			
QMCW30J507S ⁽²⁾	5 7/16 in.	23230	82.8 3.26	84.8 3.34	368.3 14.50 ⁽²⁾	205.0 8.07	304.8 12.00	184.2 7.25 ⁽²⁾	431.8 17.00	330.2 13.000	26.2 1.03	24 7/8 ⁽²⁾	75.9 2.99	204.2 8.04	206.2 8.12	116.1 4.57	121.4 4.78	12.2 0.48	192.0 7.56	102.5 226
QMCW30J508S ⁽²⁾	5 1/2 in.																			
QMCW30J140S ⁽²⁾	140 mm																			
QMCW30J515S ⁽²⁾	5 15/16 in.																			
QMCW30J600S ⁽²⁾	6 in.	23230	82.8 3.26	84.8 3.34	419.1 16.50 ⁽²⁾	205.0 8.07	304.8 12.00	209.6 8.25 ⁽²⁾	482.6 19.00	355.6 14.000	26.2 1.03	24 7/8 ⁽²⁾	75.9 2.99	211.3 8.32	213.4 8.40	116.1 4.57	128.5 5.06	19.3 0.76	192.0 7.56	101.6 224
QMCW30J150S ⁽²⁾	150 mm																			
QMCW34J607S ⁽²⁾	6 7/16 in.																			
QMCW34J608S ⁽²⁾	6 1/2 in.																			
QMCW34J170S ⁽²⁾	170 mm	23234	85.9 3.38	87.9 3.46	431.8 17.00	235.0 9.25	355.6 14.00	215.9 8.50	482.6 19.00	381.0 15.000	28.7 1.13	24 1 ⁽²⁾	85.1 3.35	216.2 8.51	218.2 8.59	129.0 5.08	130.3 5.13	2.0 0.08	214.1 8.43	152.4 336
QMCW34J615S ⁽²⁾	6 15/16 in.																			
QMCW34J700S ⁽²⁾	7 in.																			
QMCW34J180S ⁽²⁾	180 mm																			

⁽¹⁾Pilot tolerance: +0/-0.05 mm (+0/-0.002 in.).

⁽²⁾Six-bolt housing.

QMF FOUR-BOLT SQUARE FLANGE BLOCKS

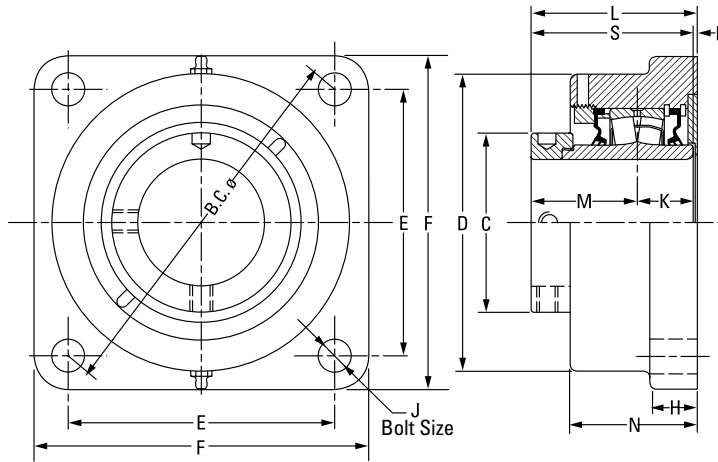

Bearing Part No.	Shaft Dia.	Bearing No.	B.C.	C	D	E	F	H	J	K	L FIX	L EXP	M	N	R	S	Wt.
	mm in.		mm in.	mm in.	mm in.	mm in.	mm in.	mm in.	mm in.	mm in.	mm in.	mm in.	mm in.	mm in.	mm in.	mm in.	lbs. kg
QMF08J035S	35 mm	22208	127.7	60.5	93.7	88.9	117.6	22.4	12	25.4	72.9	74.9	44.5	57.2	3.0	69.9	4.5
QMF08J107S	1 7/16 in.		4.95	2.38	3.69	3.50	4.63	0.88	1/2	1.00	2.87	2.95	1.75	2.25	0.12	2.75	10
QMF08J108S	1 1/2 in.	22208	148.3	60.5	108.0	104.9	136.7	22.4	12	25.4	73.7	75.7	44.5	59.4	3.8	69.9	4.5
QMF09J111S	1 13/16 in.	22209	148.3	66.8	118.4	104.9	136.7	22.4	12	25.4	79.5	81.5	47.8	63.5	6.4	73.2	5.0
QMF09J040S	40 mm		5.84	2.63	4.66	4.13	5.38	0.88	1/2	1.00	3.13	3.21	1.88	2.50	0.25	2.88	11
QMF09J112S	1 3/4 in.	22209	157.2	66.8	118.4	111.3	143.0	22.4	12	25.4	79.5	81.5	47.8	63.5	6.4	72.9	5.0
QMF09J045S	45 mm		6.19	2.63	4.66	4.38	5.63	0.88	1/2	1.00	3.13	3.21	1.88	2.50	0.25	2.87	11
QMF10J115S	1 15/16 in.	22210	157.2	71.4	120.7	111.3	139.7	22.4	12	24.4	80.8	82.8	48.0	65.0	7.9	72.9	5.0
QMF10J200S	2 in.		6.19	2.81	4.75	4.38	5.50	0.88	1/2	0.98	3.18	3.26	1.89	2.56	0.31	2.87	11
QMF10J050S	50 mm	22211	175.0	75.9	130.3	124.0	157.2	25.4	16	28.7	82.8	84.8	50.5	66.8	3.3	79.2	6.4
QMF11J203S	2 3/16 in.		6.89	2.99	5.13	4.88	6.19	1.00	5/8	1.13	3.26	3.34	1.99	2.63	0.13	3.12	14
QMF11J204S	2 1/4 in.	22213	193.0	91.9	146.1	136.7	168.4	25.4	16	31.5	88.6	90.7	54.1	72.4	3.0	85.6	7.7
QMF11J055S	55 mm		7.60	3.62	5.75	5.38	6.63	1.00	5/8	1.24	3.49	3.57	2.13	2.85	0.12	3.37	17
QMF13J060S	60 mm	22215	215.6	101.9	168.9	152.4	189.0	26.9	20	31.8	96.0	98.0	60.2	76.2	4.1	91.9	10.4
QMF13J207S	2 7/16 in.		8.49	4.01	6.65	6.00	7.44	1.06	3/4	1.25	3.78	3.86	2.37	3.00	0.16	3.62	23
QMF13J208S	2 1/2 in.	22218	251.7	120.9	193.8	177.8	219.2	33.3	20	36.6	107.2	109.2	66.8	84.1	4.8	102.4	15.9
QMF13J065S	65 mm		9.91	4.76	7.63	7.00	8.63	1.31	3/4	1.44	4.22	4.30	2.59	3.31	0.19	4.03	35
QMF15J211S	2 11/16 in.	22220	278.4	152.4	224.0	196.9	253.2	38.1	24	41.4	126.2	128.3	75.2	103.1	9.4	116.6	24.9
QMF15J212S	2 3/4 in.		10.96	6.00	8.82	7.75	9.97	1.50	7/8	1.63	4.97	5.05	2.96	4.06	0.37	4.59	55
QMF15J070S	70 mm	22222	314.5	160.0	256.8	222.3	276.4	38.1	24	46.5	150.1	152.1	94.0	106.9	9.7	140.5	28.6
QMF15J215S	2 13/16 in.		12.38	6.30	10.11	8.75	10.88	1.50	7/8	1.83	5.91	5.99	3.70	4.21	0.38	5.53	63
QMF15J300S	3 in.	22222	314.5	160.0	256.8	222.3	276.4	38.1	24	46.5	150.1	152.1	94.0	106.9	9.7	140.5	28.6
QMF15J075S	75 mm		12.38	6.30	10.11	8.75	10.88	1.50	7/8	1.83	5.91	5.99	3.70	4.21	0.38	5.53	63
QMF18J303S	3 3/16 in.	22222	314.5	160.0	256.8	222.3	276.4	38.1	24	46.5	150.1	152.1	94.0	106.9	9.7	140.5	28.6
QMF18J304S	3 1/4 in.		12.38	6.30	10.11	8.75	10.88	1.50	7/8	1.83	5.91	5.99	3.70	4.21	0.38	5.53	63
QMF18J080S	80 mm	22222	314.5	160.0	256.8	222.3	276.4	38.1	24	46.5	150.1	152.1	94.0	106.9	9.7	140.5	28.6
QMF18J085S	85 mm		12.38	6.30	10.11	8.75	10.88	1.50	7/8	1.83	5.91	5.99	3.70	4.21	0.38	5.53	63
QMF18J307S	3 7/16 in.	22222	314.5	160.0	256.8	222.3	276.4	38.1	24	46.5	150.1	152.1	94.0	106.9	9.7	140.5	28.6
QMF18J308S	3 1/2 in.		12.38	6.30	10.11	8.75	10.88	1.50	7/8	1.83	5.91	5.99	3.70	4.21	0.38	5.53	63
QMF18J090S	90 mm	22222	314.5	160.0	256.8	222.3	276.4	38.1	24	46.5	150.1	152.1	94.0	106.9	9.7	140.5	28.6
QMF20J311S	3 11/16 in.		12.38	6.30	10.11	8.75	10.88	1.50	7/8	1.83	5.91	5.99	3.70	4.21	0.38	5.53	63
QMF20J312S	3 3/4 in.	22222	314.5	160.0	256.8	222.3	276.4	38.1	24	46.5	150.1	152.1	94.0	106.9	9.7	140.5	28.6
QMF20J315S	3 15/16 in.		12.38	6.30	10.11	8.75	10.88	1.50	7/8	1.83	5.91	5.99	3.70	4.21	0.38	5.53	63
QMF20J400S	4 in.	22222	314.5	160.0	256.8	222.3	276.4	38.1	24	46.5	150.1	152.1	94.0	106.9	9.7	140.5	28.6
QMF20J100S	100 mm		12.38	6.30	10.11	8.75	10.88	1.50	7/8	1.83	5.91	5.99	3.70	4.21	0.38	5.53	63
QMF22J110S	110 mm	22222	314.5	160.0	256.8	222.3	276.4	38.1	24	46.5	150.1	152.1	94.0	106.9	9.7	140.5	28.6
QMF22J407S	4 7/16 in.		12.38	6.30	10.11	8.75	10.88	1.50	7/8	1.83	5.91	5.99	3.70	4.21	0.38	5.53	63
QMF22J408S	4 1/2 in.	22222	314.5	160.0	256.8	222.3	276.4	38.1	24	46.5	150.1	152.1	94.0	106.9	9.7	140.5	28.6
QMF22J115S	115 mm		12.38	6.30	10.11	8.75	10.88	1.50	7/8	1.83	5.91	5.99	3.70	4.21	0.38	5.53	63

QMFL FOUR-BOLT SQUARE FLANGE BLOCKS

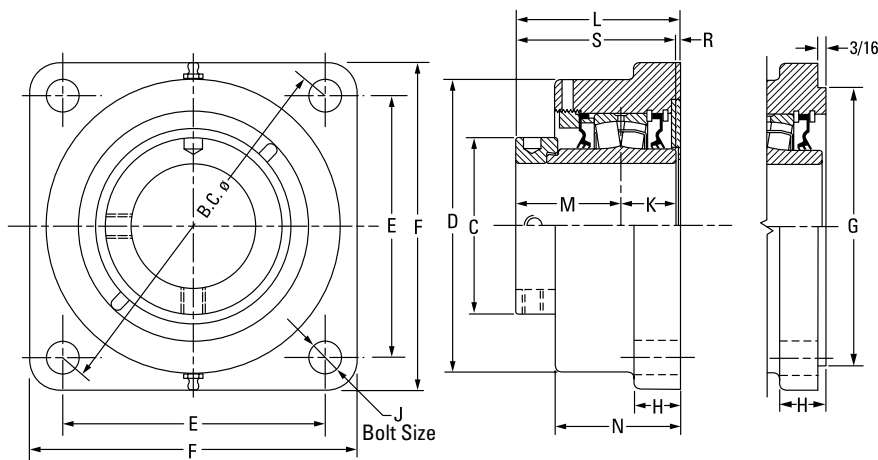

Bearing Part No.	Shaft Dia.	Bearing No.	B.C.	C	D	E	F	G ⁽¹⁾⁽²⁾⁽³⁾	H	J	K	L FIX	L EXP	M	N	R	S	Wt.
	mm in.		mm in.	mm in.	mm in.	mm in.	mm in.	mm in.	mm in.	mm in.	mm in.	mm in.	mm in.	mm in.	mm in.	mm in.	mm in.	kg lbs.
QMFL08J035S	35 mm	22208	127.0	60.5	93.7	89.9	117.6	N/A	22.4	12	25.4	72.9	74.9	44.5	57.2	3.0	69.9	4.5
QMFL08J107S	1 7/16 in.		5.00	2.38	3.69	3.54	4.63		0.88	1/2	1.00	2.87	2.95	1.75	2.25	0.12	2.75	10
QMFL08J108S	1 1/2 in.																	
QMFL09J111S	1 11/16 in.	22209	139.7	66.8	118.4	98.8	136.7	N/A	22.4	12	25.1	79.5	81.5	47.8	63.5	6.6	72.9	5.0
QMFL09J040S	40 mm		5.50	2.63	4.66	3.89	5.38		0.88	1/2	0.99	3.13	3.21	1.88	2.50	0.26	2.87	11
QMFL09J112S	1 3/4 in.																	
QMFL09J045S	45 mm	22210	146.1	71.4	115.3	103.4	131.8	N/A	23.1	12	24.9	80.8	82.8	48.0	62.5	7.9	72.9	5.0
QMFL10J115S	1 15/16 in.		5.75	2.81	4.54	4.07	5.19		0.91	1/2	0.98	3.18	3.26	1.89	2.46	0.31	2.87	11
QMFL10J200S	2 in.																	
QMFL10J050S	50 mm	22211	162.1	76.0	130.3	114.3	149.4	N/A	19.1	16	28.7	83.3	85.3	50.5	66.8	3.8	79.2	6.4
QMFL11J203S	2 3/16 in.		6.38	2.99	5.13	4.50	5.88		0.75	5/8	1.13	3.28	3.36	1.99	2.63	0.15	3.12	14
QMFL11J204S	2 1/4 in.																	
QMFL11J055S	55 mm	22213	171.5	91.9	146.1	121.2	157.2	N/A	25.4	16	31.5	88.9	90.7	54.1	72.6	3.0	85.6	7.7
QMFL13J060S	60 mm		6.75	3.62	5.75	4.77	6.19		1.00	5/8	1.24	3.50	3.57	2.13	2.86	0.12	3.37	17
QMFL13J207S	2 7/16 in.																	
QMFL13J208S	2 1/2 in.	22215	200.2	101.9	168.4	141.2	182.6	N/A	26.9	20	31.8	95.8	97.8	60.2	74.4	3.8	91.9	10.4
QMFL13J065S	65 mm		7.88	4.01	6.63	5.56	7.19		1.06	3/4	1.25	3.77	3.85	2.37	2.93	0.15	3.62	23
QMFL15J211S	2 11/16 in.																	
QMFL15J212S	2 3/4 in.	22218	241.3	120.9	193.8	170.7	212.9	187.33	32.5	20	36.6	106.4	108.5	65.8	86.4	4.1	102.4	15.9
QMFL15J070S	70 mm		7.88	4.01	6.63	5.56	7.19	7.375	1.28	3/4	1.44	4.19	4.27	2.59	3.40	0.16	4.03	35
QMFL15J215S	2 15/16 in.																	
QMFL15J300S	3 in.	22220	273.1	152.4	229.6	193.0	241.3	215.90	38.1	24	41.4	132.3	134.4	75.2	104.6	15.7	116.6	24.9
QMFL15J075S	75 mm		10.75	6.00	9.04	7.60	9.50	8.500	1.50	1	1.63	5.21	5.29	2.96	4.12	0.62	4.59	55
QMFL18J303S	3 3/16 in.																	
QMFL18J304S	3 1/4 in.	22220	273.1	152.4	229.6	193.0	241.3	215.90	38.1	24	41.4	132.3	134.4	75.2	104.6	15.7	116.6	24.9
QMFL18J080S	80 mm		10.75	6.00	9.04	7.60	9.50	8.500	1.50	1	1.63	5.21	5.29	2.96	4.12	0.62	4.59	55
QMFL18J085S	85 mm																	
QMFL18J307S	3 7/16 in.	22220	273.1	152.4	229.6	193.0	241.3	215.90	38.1	24	41.4	132.3	134.4	75.2	104.6	15.7	116.6	24.9
QMFL18J308S	3 1/2 in.		10.75	6.00	9.04	7.60	9.50	8.500	1.50	1	1.63	5.21	5.29	2.96	4.12	0.62	4.59	55
QMFL18J090S	90 mm																	
QMFL20J311S	3 11/16 in.	22220	273.1	152.4	229.6	193.0	241.3	215.90	38.1	24	41.4	132.3	134.4	75.2	104.6	15.7	116.6	24.9
QMFL20J312S	3 3/4 in.		10.75	6.00	9.04	7.60	9.50	8.500	1.50	1	1.63	5.21	5.29	2.96	4.12	0.62	4.59	55
QMFL20J315S	3 15/16 in.																	
QMFL20J400S	4 in.	22220	273.1	152.4	229.6	193.0	241.3	215.90	38.1	24	41.4	132.3	134.4	75.2	104.6	15.7	116.6	24.9
QMFL20J100S	100 mm		10.75	6.00	9.04	7.60	9.50	8.500	1.50	1	1.63	5.21	5.29	2.96	4.12	0.62	4.59	55

⁽¹⁾Pilot tolerance: +0/-0.05 mm (+0/-0.002 in.).

⁽²⁾Add (p) to the end of the housing designation in the part number to order with pilot using G dimension.

⁽³⁾Piloted flange blocks will be quoted (price and delivery) upon request. For optional spigot on flange side, insert the letter P as seen in the following example: QMFP**J***S.

QMFY ROUND FLANGE BLOCKS

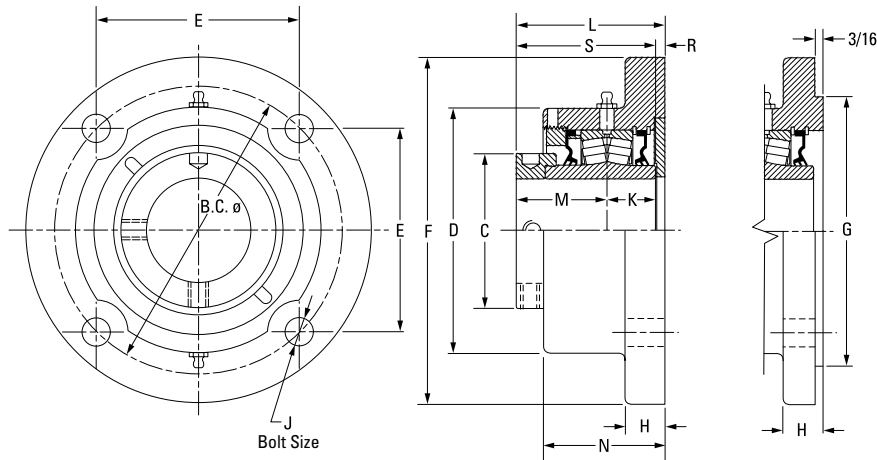

Bearing Part No.	Shaft Dia.	Bearing No.	B.C.	C	D	E	F	G ⁽¹⁾⁽²⁾⁽³⁾	H	J	K	L FIX	L EXP	M	N	R	S	Wt.
	mm in.		mm in.	mm in.	mm in.	mm in.	mm in.	mm in.	mm in.	mm in.	mm in.	mm in.	mm in.	mm in.	mm in.	mm in.	mm in.	kg lbs.
QMFY08J035S ⁽⁴⁾	35 mm	22208	127.0	60.5	108.0	110.0	158.8	90.50	19.1	12	25.4	73.2	75.2	44.5	57.4	3.3	69.9	4.5
QMFY08J107S ⁽⁴⁾	1 7/16 in.		5.00 ⁽⁴⁾	2.38	4.25	4.33 ⁽⁴⁾	6.25	3.563	0.75	1/2 ⁽⁴⁾	1.00	2.88	2.96	1.75	2.26	0.13	2.75	10
QMFY08J108S ⁽⁴⁾	1 1/2 in.																	
QMFY09J040S	40 mm	22209	139.7	66.8	104.9	98.8	171.5	103.20	20.6	12	25.1	76.2	78.2	47.8	60.5	3.0	72.9	5.0
QMFY09J111S	1 11/16 in.		5.50	2.63	4.13	3.89	6.75	4.063	0.81	1/2	0.99	3.00	3.08	1.88	2.38	0.12	2.87	11
QMFY09J112S	1 3/4 in.																	
QMFY09J045S	45 mm	22210	146.1	71.4	115.3	103.4	177.8	111.13	19.1	12	24.9	75.9	78.0	48.0	58.4	3.0	72.9	5.4
QMFY10J115S	1 5/16 in.		5.75	2.81	4.54	4.07	7.00	4.375	0.75	1/2	0.98	2.99	3.07	1.89	2.30	0.12	2.87	12
QMFY10J200S	2 in.																	
QMFY10J050S	50 mm	22211	162.1	75.9	130.3	114.3	196.9	127.00	19.1	16	28.7	82.3	84.3	50.8	62.0	3.0	79.2	6.8
QMFY11J203S	2 3/8 in.		6.38	2.99	5.13	4.50	7.75	5.000	0.75	5/8	1.13	3.24	3.32	2.00	2.44	0.12	3.12	15
QMFY11J204S	2 1/4 in.																	
QMFY11J055S	55 mm	22213	171.5	91.9	146.1	121.2	206.5	138.13	23.9	16	31.5	88.1	90.4	54.1	72.4	2.3	85.6	8.6
QMFY13J060S	60 mm		6.75	3.62	5.75	4.77	8.13	5.438	0.94	5/8	1.24	3.47	3.56	2.13	2.85	0.09	3.37	19
QMFY13J207S	2 7/16 in.																	
QMFY13J208S	2 1/2 in.	22215	199.9	101.9	168.4	141.2	241.3	160.35	23.9	20	31.8	98.6	100.6	60.2	76.2	6.4	91.9	12.7
QMFY13J065S	65 mm		7.87	4.01	6.63	5.56	9.50	6.313	0.94	3/4	1.25	3.88	3.96	2.37	3.00	0.25	3.62	28
QMFY15J211S	2 11/16 in.																	
QMFY15J212S	2 3/4 in.																	
QMFY15J070S	70 mm																	
QMFY15J215S	2 5/8 in.																	
QMFY15J300S	3 in.																	
QMFY15J075S	75 mm																	

⁽¹⁾Pilot tolerance: +0/-0.05 mm (+0/-0.002 in.).

⁽²⁾Add (p) to the end of the housing designation in the part number to order with pilot using G dimension.

⁽³⁾Piloted flange blocks will be quoted (price and delivery) upon request. For optional spigot on flange side, insert the letter P as seen in the following example: QMFP**J***S.

⁽⁴⁾Three-bolt housing.

NOTE: Housings also are available with a 3/16 in. machined pilot. Please contact your Timken engineer for more information.

Continued on next page.

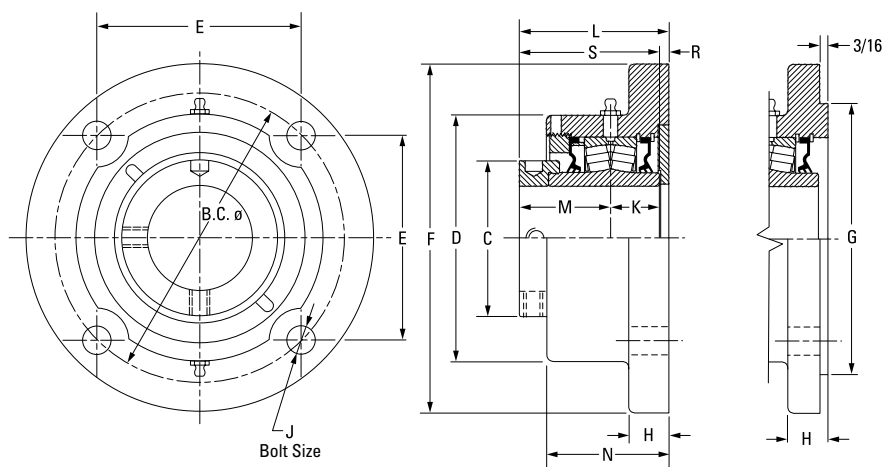

Continued from previous page.

Bearing Part No.	Shaft Dia.	Bearing No.	B.C.	C	D	E	F	G ⁽¹⁾⁽²⁾⁽³⁾	H	J	K	L FIX	L EXP	M	N	R	S	Wt.
	mm in.		mm in.	mm in.	mm in.	mm in.	mm in.	mm in.	mm in.	mm in.	mm in.	mm in.	mm in.	mm in.	mm in.	mm in.	mm in.	kg lbs.
QMFY18J303S	3 3/16 in.	22218	241.3 9.50	120.9 4.76	193.8 7.63	170.7 6.72	282.7 11.13	N/A	28.7 1.13	24 7/8	36.6 1.44	108.7 4.28	110.7 4.36	65.8 2.59	85.3 3.36	6.4 0.25	102.4 4.03	19.1 42
QMFY18J304S	3 1/4 in.																	
QMFY18J080S	80 mm																	
QMFY18J085S	85 mm																	
QMFY18J307S	3 7/16 in.																	
QMFY18J308S	3 1/2 in.																	
QMFY18J090S	90 mm	22220	273.1 10.75	152.4 6.00	222.5 8.76	193.0 7.60	320.8 12.63	N/A	28.7 1.13	24 1	41.4 1.63	123.7 4.87	125.7 4.95	75.2 2.96	103.1 4.06	6.9 0.27	116.6 4.59	29.9 66
QMFY20J311S	3 11/16 in.																	
QMFY20J312S	3 3/4 in.																	
QMFY20J315S	3 15/16 in.																	
QMFY20J400S	4 in.																	
QMFY20J100S	100 mm																	
QMFY22J110S ⁽⁵⁾	110 mm	22222	327.2 12.88 ⁽⁵⁾	160.0 6.30	254.0 10.00	163.6 6.44 ⁽⁵⁾	384.3 15.13	N/A	31.8 1.25	24 1 ⁽⁵⁾	46.5 1.83	143.5 5.65	145.5 5.73	94.0 3.70	100.3 3.95	3.0 0.12	140.5 5.53	46.3 102
QMFY22J407S ⁽⁵⁾	4 7/16 in.																	
QMFY22J408S ⁽⁵⁾	4 1/2 in.																	
QMFY22J115S ⁽⁵⁾	115 mm																	
QMFY26J125S ⁽⁵⁾	125 mm																	
QMFY26J415S ⁽⁵⁾	4 15/16 in.																	
QMFY26J500S ⁽⁵⁾	5 in.	22226	355.6 14.00 ⁽⁵⁾	175.0 6.89	284.2 11.19	177.8 7.00 ⁽⁵⁾	419.1 16.50	N/A	38.1 1.50	24 1 1/8 ⁽⁵⁾	58.7 2.31	170.2 6.70	172.2 6.78	94.7 3.73	138.4 5.45	16.8 0.66	153.4 6.04	52.2 115
QMFY26J130S ⁽⁵⁾	130 mm																	

¹⁾Pilot tolerance: +0/-0.05 mm (+0/-0.002 in.).

²⁾Add (p) to the end of the housing designation in the part number to order with pilot using G dimension.

³⁾Piloted flange blocks will be quoted (price and delivery) upon request. For optional spigot on flange side, insert the letter P as seen in the following example: QMFY**J***S.

⁴⁾Three-bolt housing.

⁵⁾Six-bolt housing.

NOTE: Housings also are available with a 3/16 in. machined pilot. Please contact your Timken engineer for more information.

QMF5000 SERIES SQUARE FLANGE BLOCKS

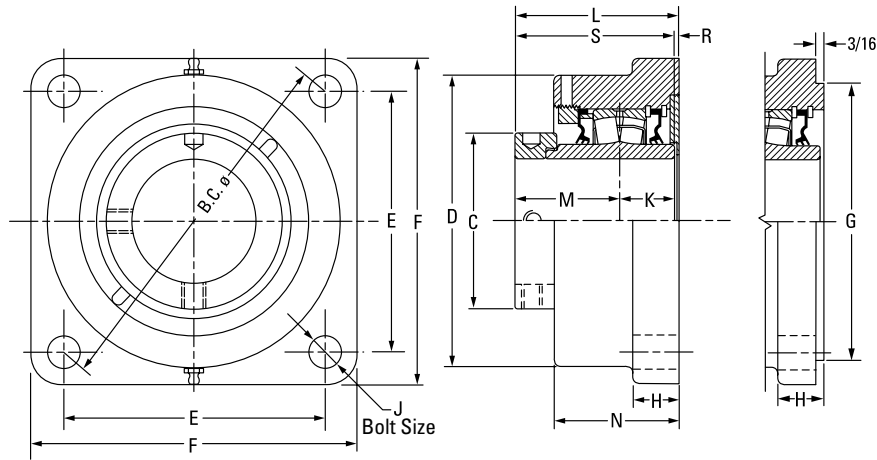

Bearing Part No.	Shaft Dia.	Bearing No.	B.C.	C	D	E	F	G ⁽¹⁾⁽²⁾⁽³⁾	H	J	K	L FIX	L EXP	M	N	R	S	Wt.																	
	mm in.		mm in.	mm in.	mm in.	mm in.	mm in.	mm in.	mm in.	mm in.	mm in.	mm in.	mm in.	mm in.	mm in.	mm in.	mm in.	kg lbs.																	
QMF08J035S	35 mm	22208	133.6	59.9	93.7	94.5	117.6	90.50	22.1	12	25.4	72.9	74.9	44.5	57.2	3.0	69.9	4.5																	
QMF08J107S	1 7/16 in.		5.26	2.36	3.69	3.72	4.63	3.563	0.88	1/2	1.00	2.87	2.95	1.75	2.25	0.12	2.75	10																	
QMF08J108S	1 1/2 in.	22208	139.7	59.9	108.0	98.8	130.3	103.20	22.1	12	25.4	73.7	75.7	44.5	59.4	3.81	69.9	4.5																	
QMF09J040S	40 mm	22209	139.7	66.8	108.0	98.8	130.3	103.20	22.1	12	25.1	79.5	81.5	47.8	63.5	6.4	72.9	5.0																	
QMF09J111S	1 11/16 in.																		5.50	2.63	4.25	3.89	5.13	4.063	0.88	1/2	0.99	3.13	3.21	1.88	2.50	0.25	2.87	11	
QMF09J112S	1 3/4 in.																																		
QMF09J045S	45 mm	22210	146.1	71.4	120.7	103.1	134.9	111.13	22.1	12	24.9	80.8	82.8	48.0	65.0	7.9	72.9	5.0																	
QMF10J115S	1 15/16 in.																		5.75	2.81	4.75	4.06	5.31	4.375	0.88	1/2	0.98	3.18	3.26	1.89	2.56	0.31	2.87	11	
QMF10J200S	2 in.																																		
QMF10J050S	50 mm	22211	161.5	75.9	130.3	114.3	149.4	127.00	25.4	16	28.7	83.1	85.1	50.5	66.8	3.3	79.2	5.0																	
QMF11J203S	2 3/16 in.																		6.36	2.99	5.13	4.50	5.88	5.000	1.00	5/8	1.13	3.27	3.35	1.99	2.63	0.13	3.12	11	
QMF11J204S	2 1/4 in.																																		
QMF11J055S	55 mm	22213	180.8	91.9	146.1	127.8	157.2	138.13	25.4	16	31.5	89.2	91.2	54.1	72.4	3.0	85.6	6.4																	
QMF13J060S	60 mm																		7.12	3.62	5.75	5.03	6.19	5.438	1.00	5/8	1.24	3.51	3.59	2.13	2.85	0.12	3.37	14	
QMF13J207S	2 7/16 in.																																		
QMF13J208S	2 1/2 in.																																		
QMF13J065S	65 mm	22215	215.9	102.1	168.9	152.7	189.0	160.35	26.9	20	31.8	96.0	98.0	60.2	76.2	4.1	91.9	7.7																	
QMF15J211S	2 11/16 in.																		8.50	4.02	6.65	6.01	7.44	6.313	1.06	3/4	1.25	3.78	3.86	2.37	3.00	0.16	3.62	17	
QMF15J212S	2 3/4 in.																																		
QMF15J070S	70 mm																																		
QMF15J215S	2 15/16 in.																																		
QMF15J300S	3 in.																																		
QMF15J075S	75 mm																																		

⁽¹⁾Pilot tolerance: +0/-0.05 mm (+0/-0.002 in.).

⁽²⁾Add (p) to the end of the housing designation in the part number to order with pilot using G dimension.

⁽³⁾Piloted flange blocks will be quoted (price and delivery) upon request. For optional spigot on flange side, insert the letter P as seen in the following example: QMFP**J***S.

⁽⁴⁾Six-bolt round housing.

Continued on next page.

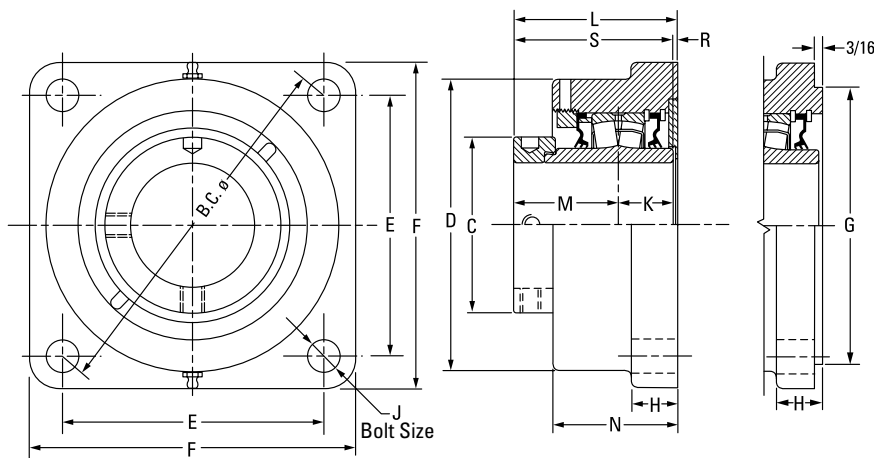

Continued from previous page.

Bearing Part No.	Shaft Dia.	Bearing No.	B.C.	C	D	E	F	G ⁽¹⁾⁽²⁾⁽³⁾	H	J	K	L FIX	L EXP	M	N	R	S	Wt.
	mm in.		mm in.	mm in.	mm in.	mm in.	mm in.	mm in.	mm in.	mm in.	mm in.	mm in.	mm in.	mm in.	mm in.	mm in.	mm in.	kg lbs.
QMF518J303S	3 3/8 in.	22218	241.3 9.50	120.9 4.76	193.8 7.63	170.7 6.72	212.9 8.38	187.33 7.375	33.3 1.31	20 3/4	36.6 1.44	107.2 4.22	109.2 4.30	65.8 2.59	84.1 3.31	4.8 0.19	102.4 4.03	10.4 23
QMF518J304S	3 1/4 in.																	
QMF518J080S	80 mm																	
QMF518J085S	85 mm																	
QMF518J307S	3 7/8 in.																	
QMF518J308S	3 1/2 in.																	
QMF518J090S	90 mm	22220	298.5 11.75	152.4 6.00	215.9 8.50	211.1 8.31	268.2 10.56	225.43 8.875	38.1 1.50	24 7/8	41.4 1.63	126.0 4.96	128.0 5.04	75.2 2.96	103.1 4.06	9.4 0.37	116.8 4.60	15.9 35
QMF520J311S	3 11/16 in.																	
QMF520J312S	3 3/4 in.																	
QMF520J315S	3 15/16 in.																	
QMF520J400S	4 in.																	
QMF520J100S	100 mm																	
QMF522J110S ⁽⁴⁾	110 mm	22222	327.2 12.88 ⁽¹⁾	160.0 6.30	256.5 10.10	163.6 6.44 ⁽¹⁾	384.3 15.13	263.53 10.375	31.8 1.25	24 1 ⁽¹⁾	46.5 1.83	143.8 5.66	145.8 5.74	94.0 3.70	106.9 4.21	3.3 0.13	140.5 5.53	46.3 102
QMF522J407S ⁽⁴⁾	4 7/8 in.																	
QMF522J408S ⁽⁴⁾	4 1/2 in.																	
QMF522J115S ⁽⁴⁾	115 mm																	
QMF526J125S ⁽⁴⁾	125 mm																	
QMF526J415S ⁽⁴⁾	4 15/16 in.																	
QMF526J500S ⁽⁴⁾	5 in.	22226	355.6 14.00 ⁽¹⁾	175.0 6.89	284.2 11.19	177.8 7.00 ⁽¹⁾	419.1 16.50	284.18 11.188	38.1 1.50	24 1 1/8 ⁽¹⁾	58.7 2.31	172.2 6.78	174.2 6.86	94.7 3.73	135.1 5.32	17.3 0.68	153.4 6.04	52.2 115
QMF526J130S ⁽⁴⁾	130 mm																	

⁽¹⁾Pilot tolerance: +0/-0.05 mm (+0/-0.002 in.).

⁽²⁾Add (p) to the end of the housing designation in the part number to order with pilot using G dimension.

⁽³⁾Piloted flange blocks will be quoted (price and delivery) upon request. For optional spigot on flange side, insert the letter P as seen in the following example: QMFP**J***S.

⁽⁴⁾Six-bolt round housing.

QMMC CARTRIDGE BLOCKS

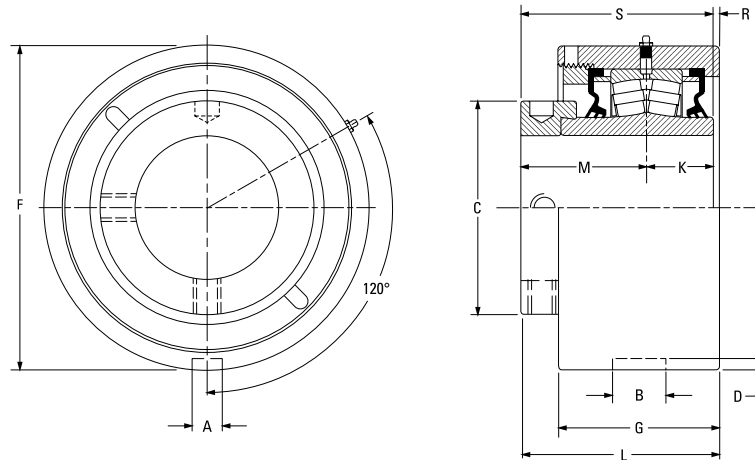

Bearing Part No.	Shaft Dia.	Bearing No.	A	B	C	D	F	G	K	L FIX	L EXP	M	R	S	Wt.
	mm in.		mm in.	mm in.	mm in.	mm in.	mm in.	mm in.	mm in.	mm in.	mm in.	mm in.	mm in.	mm in.	kg lbs.
QMMC10J115S	1 1/16 in.	22210	13.5	23.1	71.4	4.8	104.78 (+0/-0.05)	62.2	24.9	79.2	81.3	48.0	6.1	72.9	3.6
QMMC10J200S	2 in.		0.53	0.91	2.81	0.19	4.125 (+0/-0.002)	2.45	0.98	3.12	3.20	1.89	0.24	2.87	8
QMMC10J050S	50 mm														
QMMC11J203S	2 3/16 in.	22211	13.5	23.1	75.9	4.8	115.09 (+0/-0.05)	65.5	28.7	83.6	85.6	50.5	4.1	79.2	4.5
QMMC11J204S	2 1/4 in.		0.53	0.91	2.99	0.19	4.531 (+0/-0.002)	2.58	1.13	3.29	3.37	1.99	0.16	3.12	10
QMMC11J055S	55 mm														
QMMC13J060S ⁽¹⁾	60 mm	22213	13.5	23.1	91.9	4.8	127.00 (+0/-0.05)	69.3	31.5	85.6	87.6	54.1	0.0	85.6	5.4
QMMC13J207S ⁽¹⁾	2 7/16 in.		0.53	0.91	3.62	0.19	5.000 (+0/-0.002)	2.73	1.24	3.37	3.45	2.13	0.00	3.37	12
QMMC13J208S ⁽¹⁾	2 1/2 in.														
QMMC13J065S ⁽¹⁾	65 mm	22215	15.0	26.2	101.9	6.4	149.225 (+0/-0.05)	79.8	31.8	100.1	102.1	60.2	8.1	91.9	8.2
QMMC15J211S	2 1/16 in.		0.59	1.03	4.01	0.25	5.875 (+0/-0.002)	3.14	1.25	3.94	4.02	2.37	0.32	3.62	18
QMMC15J212S	2 3/4 in.														
QMMC15J070S	70 mm	22218	15.0	26.2	101.9	6.4	149.225 (+0/-0.05)	79.8	31.8	100.1	102.1	60.2	8.1	91.9	8.2
QMMC15J215S	2 15/16 in.		0.59	1.03	4.01	0.25	5.875 (+0/-0.002)	3.14	1.25	3.94	4.02	2.37	0.32	3.62	18
QMMC15J300S	3 in.														
QMMC15J075S	75 mm	22220	19.8	32.5	152.4	7.9	206.375 (+0/-0.05)	105.2	41.4	128.0	130.0	75.2	11.4	116.6	14.5
QMMC18J303S	3 3/16 in.		0.78	1.28	6.00	0.31	8.125 (+0/-0.002)	4.14	1.63	5.039	5.12	2.96	0.45	4.59	32
QMMC18J304S	3 1/4 in.														
QMMC18J080S	80 mm	22218	15.0	26.9	120.9	7.1	171.45 (+0/-0.05)	87.6	36.6	109.7	111.8	65.0	7.4	102.4	11.8
QMMC18J085S	85 mm		0.59	1.06	4.76	0.28	6.750 (+0/-0.002)	3.45	1.44	4.32	4.40	2.56	0.29	4.03	26
QMMC18J307S	3 7/16 in.														
QMMC18J308S	3 1/2 in.	22220	19.8	32.5	152.4	7.9	206.375 (+0/-0.05)	105.2	41.4	128.0	130.0	75.2	11.4	116.6	14.5
QMMC18J090S	90 mm		0.78	1.28	6.00	0.31	8.125 (+0/-0.002)	4.14	1.63	5.039	5.12	2.96	0.45	4.59	32
QMMC20J311S	3 1/16 in.														
QMMC20J312S	3 3/4 in.	22220	19.8	32.5	152.4	7.9	206.375 (+0/-0.05)	105.2	41.4	128.0	130.0	75.2	11.4	116.6	14.5
QMMC20J315S	3 15/16 in.		0.78	1.28	6.00	0.31	8.125 (+0/-0.002)	4.14	1.63	5.039	5.12	2.96	0.45	4.59	32
QMMC20J400S	4 in.														
QMMC20J100S	100 mm														

⁽¹⁾The grub screw is located in the external housing nut to secure to the housing.

Continued on next page.

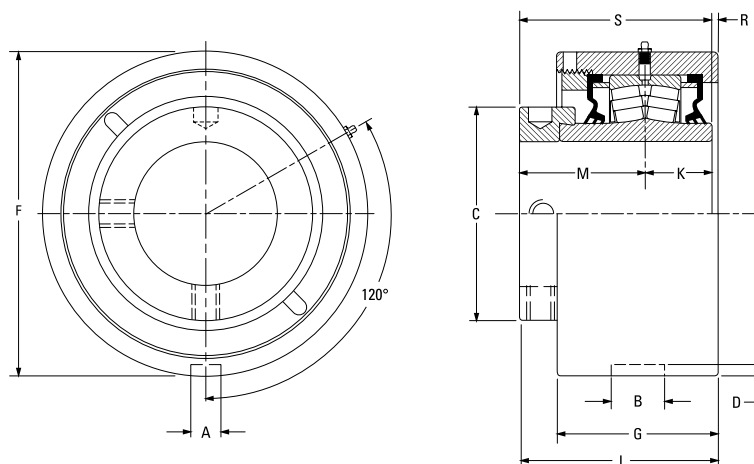

Continued from previous page.

Bearing Part No.	Shaft Dia.	Bearing No.	A	B	C	D	F	G	K	L FIX	L EXP	M	R	S	Wt.
	mm in.		mm in.	mm in.	mm in.	mm in.	mm in.	mm in.	mm in.	mm in.	mm in.	mm in.	mm in.	mm in.	kg lbs.
QMMC22J110S	110 mm	22222	19.8 0.78	38.1 1.50	160.0 6.30	7.9 0.31	222.25 (+0/-0.08) 8.75 (+0/-0.003)	108.5 4.27	46.5 1.83	148.0 5.83	150.1 5.91	94.0 3.70	7.6 0.30	140.5 5.53	18.1 40
QMMC22J407S	4 7/16 in.														
QMMC22J408S	4 1/2 in.														
QMMC22J115S	115 mm														
QMMC26J125S	125 mm	22226	19.8 0.78	38.1 1.50	175.0 6.89	7.9 0.31	265.13 (+0/-0.08) 10.438 (+0/-0.003)	141.7 5.58	58.7 2.31	165.4 6.51	167.4 6.59	94.7 3.73	11.9 0.47	153.4 6.04	31.8 70
QMMC26J415S	4 15/16 in.														
QMMC26J500S	5 in.														
QMMC26J130S	130 mm														
QMMC30J507S	5 7/16 in.	23230	19.8 0.78	38.1 1.50	205.0 8.07	5.6 0.22	292.10 (+0/-0.08) 11.500 (+0/-0.003)	154.4 6.08	75.9 2.99	188.2 7.41	190.2 7.49	116.1 4.57	-3.8 -0.15	192.0 7.56	88.0 194
QMMC30J508S	5 1/2 in.														
QMMC30J140S	140 mm														
QMMC30J515S	5 15/16 in.														
QMMC30J600S	6 in.	23230	19.8 0.78	38.1 1.50	205.0 8.07	5.6 0.22	311.15 (+0/-0.08) 12.250 (+0/-0.003)	154.4 6.08	75.9 2.99	188.2 7.41	190.2 7.49	116.1 4.57	-3.8 -0.15	192.0 7.56	87.1 192
QMMC30J150S	150 mm														
QMMC34J607S	6 7/16 in.														
QMMC34J608S	6 1/2 in.														
QMMC34J170S	170 mm	23234	19.8 0.78	38.1 1.50	235.0 9.25	5.6 0.22	344.50 (+0/-0.08) 13.563 (+0/-0.003)	181.1 7.13	85.1 3.35	219.5 8.64	221.5 8.72	129.0 5.08	5.33 0.21	214.1 8.43	155.6 343
QMMC34J615S	6 15/16 in.														
QMMC34J700S	7 in.														
QMMC34J180S	180 mm														

⁽¹⁾The grub screw is located in the external housing nut to secure to the housing.

QMTU TAKE-UP BLOCKS

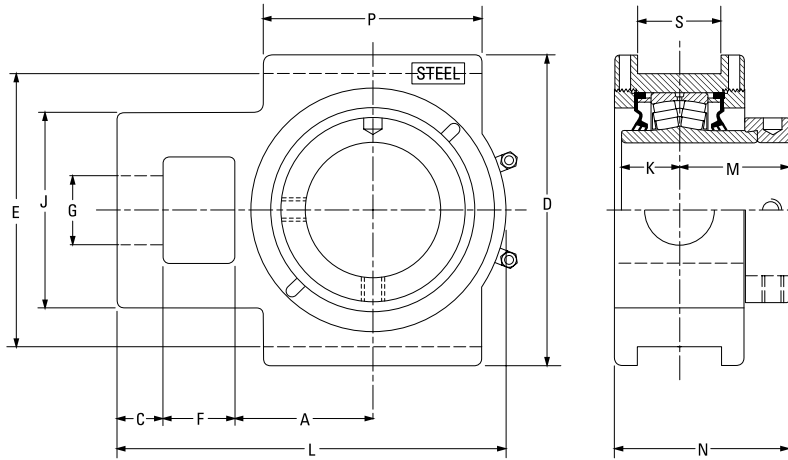

Bearing Part No.	Shaft Dia.	Bearing No.	A	C	D	E	F	G	J	K	L	M	N	P	S	Wt.
	mm in.		mm in.	mm in.	mm in.	mm in.	mm in.	mm in.	mm in.	mm in.	mm in.	mm in.	mm in.	mm in.	mm in.	kg lbs.
QMTU10J115S	1 1/8 in.	22210	54.1	19.1	120.7	101.6	26.9	26.9	73.2	24.9	153.4	48.0	76.7	88.9	17.5	7.7
QMTU10J200S	2 in.		2.13	0.75	4.75	4.00	1.06	1.06	2.88	0.98	6.04	1.89	3.02	3.50	0.69	17
QMTU10J050S	50 mm															
QMTU11J203S	2 3/8 in.	22211	60.5	19.1	133.4	114.3	30.2	30.2	88.9	28.7	167.9	50.5	82.8	95.3	20.6	9.5
QMTU11J204S	2 1/2 in.		2.38	0.75	5.25	4.50	1.19	1.19	3.50	1.13	6.61	1.99	3.26	3.75	0.81	21
QMTU11J055S	55 mm															
QMTU13J060S	60 mm	22213	69.9	22.4	149.4	130.3	33.3	34.9	95.3	31.5	193.8	54.1	90.7	120.7	26.9	12.2
QMTU13J207S	2 7/8 in.		2.75	0.88	5.88	5.13	1.31	1.38	3.75	1.24	7.63	2.13	3.57	4.75	1.06	27
QMTU13J208S	2 1/2 in.															
QMTU13J065S	65 mm	22215	76.2	25.4	171.5	150.9	39.6	39.6	108.0	31.8	219.7	60.2	97.0	120.7	46.0	15.9
QMTU15J211S	2 1/8 in.		3.00	1.00	6.75	5.94	1.56	1.56	4.25	1.25	8.65	2.37	3.82	4.75	1.81	35
QMTU15J212S	2 3/4 in.															
QMTU15J070S	70 mm	22218	92.2	25.4	193.8	173.0	46.0	49.3	124.0	36.6	257.0	65.8	106.4	158.8	46.0	20.0
QMTU15J300S	3 in.		3.63	1.00	7.63	6.81	1.81	1.94	4.88	1.44	10.12	2.59	4.19	6.25	1.81	44
QMTU15J075S	75 mm															
QMTU18J303S	3 3/8 in.	22220	104.9	28.7	239.8	219.2	54.1	52.3	143.0	41.4	296.9	75.4	120.4	177.8	52.3	26.3
QMTU18J304S	3 1/4 in.		4.13	1.13	9.44	8.63	2.13	2.06	5.63	1.63	11.69	2.97	4.74	7.00	2.06	58
QMTU18J080S	80 mm															
QMTU18J085S	85 mm	22222	128.5	38.1	263.7	241.3	54.1	54.1	162.1	46.5	341.4	94.0	143.8	199.9	52.3	36.4
QMTU18J307S	3 7/8 in.		5.06	1.50	10.38	9.50	2.13	2.13	6.38	1.83	13.44	3.70	5.66	7.87	2.06	80
QMTU18J308S	3 1/2 in.															
QMTU18J090S	90 mm	22226	134.9	63.5	285.8	260.4	63.5	60.5	177.8	58.7	396.7	94.7	151.1	228.6	52.3	60.8
QMTU20J311S	3 1/8 in.		5.31	2.50	11.25	10.25	2.50	2.38	7.00	2.31	15.62	3.73	5.95	9.00	2.06	134
QMTU20J312S	3 3/4 in.															
QMTU20J315S	3 1/2 in.	22226	134.9	63.5	285.8	260.4	63.5	60.5	177.8	58.7	396.7	94.7	151.1	228.6	52.3	60.8
QMTU20J400S	4 in.		5.31	2.50	11.25	10.25	2.50	2.38	7.00	2.31	15.62	3.73	5.95	9.00	2.06	134
QMTU20J100S	100 mm															
QMTU22J110S	110 mm	22222	128.5	38.1	263.7	241.3	54.1	54.1	162.1	46.5	341.4	94.0	143.8	199.9	52.3	36.4
QMTU22J407S	4 7/8 in.		5.06	1.50	10.38	9.50	2.13	2.13	6.38	1.83	13.44	3.70	5.66	7.87	2.06	80
QMTU22J408S	4 1/2 in.															
QMTU22J115S	115 mm	22226	134.9	63.5	285.8	260.4	63.5	60.5	177.8	58.7	396.7	94.7	151.1	228.6	52.3	60.8
QMTU26J125S	125 mm		5.31	2.50	11.25	10.25	2.50	2.38	7.00	2.31	15.62	3.73	5.95	9.00	2.06	134
QMTU26J415S	4 1/8 in.															
QMTU26J500S	5 in.	22226	134.9	63.5	285.8	260.4	63.5	60.5	177.8	58.7	396.7	94.7	151.1	228.6	52.3	60.8
QMTU26J130S	130 mm		5.31	2.50	11.25	10.25	2.50	2.38	7.00	2.31	15.62	3.73	5.95	9.00	2.06	134

NOTE: Please refer to page 206 for take-up frames.

QMTP – TOP PULL TAKE-UP BLOCKS

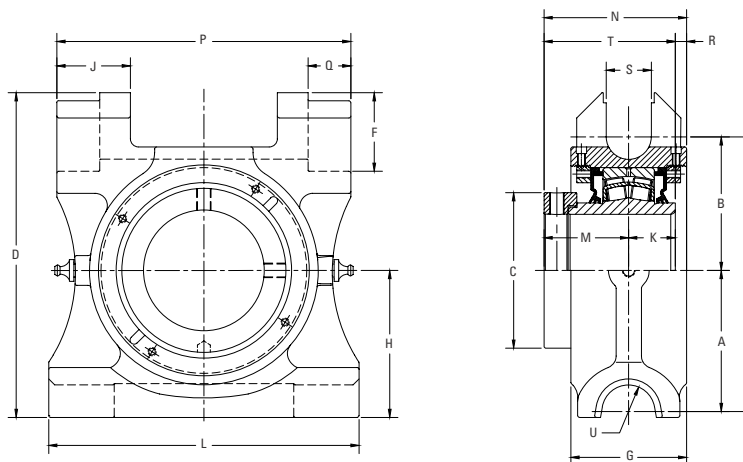

Bearing Part No.	Shaft Dia.	Bearing No.	A	B	C	D	E	F	G	H	J	K	L	M	N	P	Q	R	S	T	U
			mm in.	mm in.	mm in.	mm in.	mm in.	mm in.	mm in.	mm in.	mm in.	mm in.	mm in.	mm in.	mm in.	mm in.	mm in.	mm in.	mm in.	mm in.	mm in.
QMTP10J115S	1 1/16 in.	22210	71.4	60.5	71.4	163.6	131.8	42.2	62.7	77.8	41.9	24.9	165.1	48.0	79.3	152.4	20.6	6.4	22.4	72.9	20.6
QMTP10J200S	2 in.		2.81	2.38	2.81	6.44	5.19	1.66	2.47	3.06	1.65	0.98	6.50	1.89	3.12	6.00	0.81	.025	0.88	2.87	0.81
QMTP10J050S	50 mm																				
QMTP11J203S	2 3/16 in.	22211	82.6	72.8	79.1	193.8	155.4	49.3	69.9	88.9	44.4	28.6	190.6	50.6	88.3	177.8	26.9	9.1	28.4	79.2	20.6
QMTP11J204S	2 1/4 in.		3.25	2.87	3.12	7.63	6.12	1.94	2.75	3.50	1.75	1.13	7.50	1.99	3.48	7.00	1.06	0.36	1.12	3.12	0.81
QMTP11J055S	55 mm																				
QMTP13J207S	2 7/16 in.	22213	96.8	84.6	91.9	210.3	181.4	47.8	81.0	97.5	44.5	31.5	215.9	54.2	94.7	203.2	26.9	9.0	28.4	85.7	20.6
QMTP13J208S	2 1/2 in.		3.81	3.33	3.62	8.28	7.14	1.88	3.19	3.84	1.75	1.24	8.50	2.13	3.73	8.00	1.06	0.35	1.12	3.37	0.81
QMTP13J060S	60 mm																				
QMTP15J211S	2 11/16 in.	22215	97.0	84.1	101.7	215.9	181.1	49.3	81.0	101.4	44.4	31.8	215.9	60.2	100.7	203.2	26.9	8.7	28.4	92.0	20.6
QMTP15J212S	2 3/4 in.		3.82	3.31	4.00	8.50	7.13	1.94	3.19	3.99	1.75	1.25	8.50	2.37	3.96	8.00	1.06	0.34	1.12	3.62	0.81
QMTP15J070S	70 mm																				
QMTP15J215S	2 15/16 in.	22218	109.7	103.9	121.0	252.5	213.6	61.3	90.0	114.3	57.1	36.3	241.3	65.8	110.9	228.6	33.3	8.8	35.1	102.1	20.6
QMTP15J300S	3 in.		4.32	4.09	4.76	9.94	8.41	2.41	3.54	4.50	2.25	1.43	9.50	2.59	4.37	9.00	1.31	0.35	1.38	4.02	0.81
QMTP15J075S	75 mm																				
QMTP18J303S	3 3/16 in.	22220	121.0	117.6	152.5	289.1	238.6	63.5	79.5	139.7	58.7	41.3	279.4	75.5	126.2	266.7	33.3	9.4	35.1	116.8	20.6
QMTP18J304S	3 1/4 in.		4.76	4.63	6.00	11.38	9.39	2.50	3.13	5.50	2.31	1.63	11.00	2.97	4.97	10.50	1.31	0.37	1.37	4.60	0.81
QMTP18J080S	80 mm																				
QMTP18J085S	85 mm																				
QMTP18J307S	3 7/16 in.																				
QMTP18J308S	3 1/2 in.																				
QMTP18J090S	90 mm																				
QMTP20J311S	3 11/16 in.																				
QMTP20J312S	3 3/4 in.																				
QMTP20J315S	3 15/16 in.																				
QMTP20J400S	4 in.																				
QMTP20J100S	100 mm																				

QMMH HANGER BLOCKS

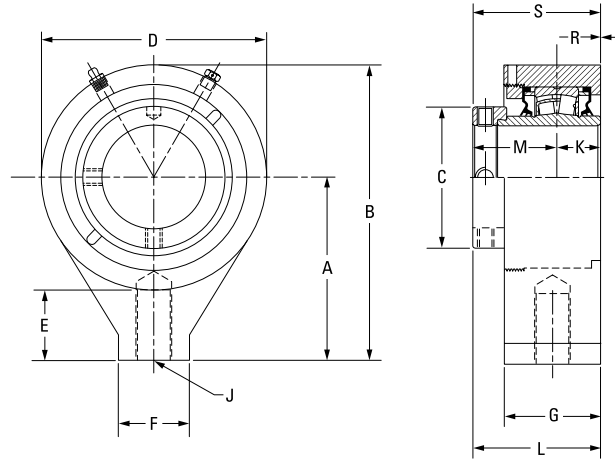

Bearing Part No.	Shaft Dia.	Bearing No.	A	B	C	D	E	F	G	J	K	L	M	R	S	Wt.
	mm in.		mm in.	mm in.	mm in.	mm in.	mm in.	mm in.	mm in.	in.	mm in.	mm in.	mm in.	mm in.	mm in.	kg lbs.
QMMH15J211S	2 1/16 in.	22215	131.8 5.19	212.9 8.38	101.9 4.01	162.1 6.38	50.8 2.00	50.8 2.00	69.9 2.75	1-8UNC	31.8 1.25	91.9 3.62	60.2 2.37	0.0 0.00	91.9 3.62	10.0 22
QMMH15J212S	2 3/8 in.															
QMMH15J070S	70 mm															
QMMH15J215S	2 15/16 in.															
QMMH15J300S	3 in.															
QMMH15J075S	75 mm	22218	160.3 6.31	260.4 10.25	120.9 4.76	200.2 7.88	63.5 2.50	76.2 3.00	76.2 3.00	1 1/4-7UNC	36.6 1.44	99.3 3.91	65.8 2.59	3.0 0.12	102.4 4.03	16.3 36
QMMH18J303S	3 3/16 in.															
QMMH18J304S	3 1/4 in.															
QMMH18J080S	80 mm															
QMMH18J085S	85 mm															
QMMH18J307S	3 7/16 in.															
QMMH18J308S	3 1/2 in.															
QMMH18J090S	90 mm															

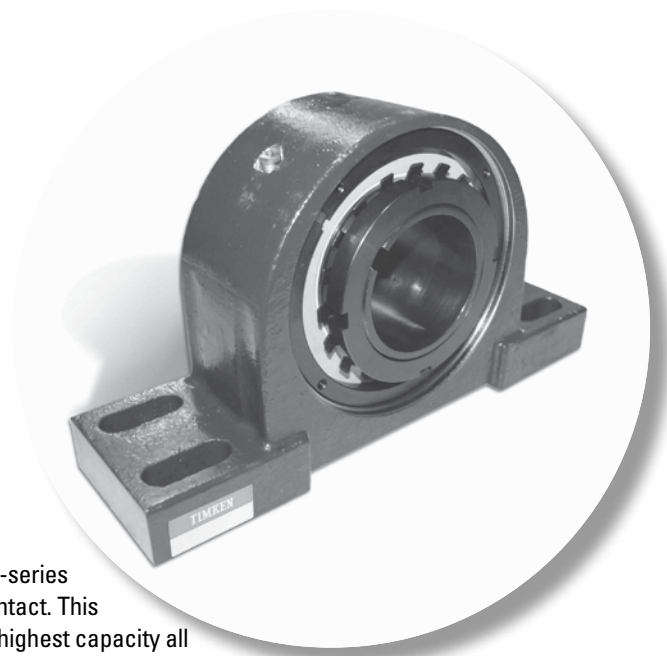

TA/DV TAA/DAA SERIES

The TA/DV and TAA/DAA series feature a 2300-series tapered adapter sleeve for increased shaft contact. This design offers the best shaft concentricity and highest capacity all the while having the ability to accommodate undersized shafting.

The following topics are covered within this section:

Introduction	176
DAAP Two-Bolt Pillow Blocks	177
TAAPA SAF-Style Two-Bolt Pillow Blocks	178
TAAPN SN-Style Two-Bolt Pillow Blocks	179
TAASD Special Duty-Style Two-Bolt Pillow Blocks	180
TAADI DI-Style Two-Bolt Pillow Block	181
TAAPKT 9000 Series Two-Bolt Pillow Blocks	182
DAAPF Four-Bolt Pillow Blocks	183
TAAPK 9000 Series Four-Bolt Pillow Blocks	184
TAA4SD Special Duty-Style Four-Bolt Pillow Block	185
TAA4DI DI-Style Four-Bolt Pillow Block	187
TAAPH SAF-Style Four-Bolt Pillow Blocks	188
TAAPH SAF 500-Style Four-Bolt Pillow Blocks	189
TAAPHD SDAF 500-Style Four-Bolt Pillow Blocks	190
TAAPH6 SAF 600-Style Four-Bolt Pillow Blocks	191
TAAPH6D SDAF 600-Style Four Bolt Pillow Blocks	192
TAAPH0 SAF 230-Style Four-Bolt Pillow Blocks	193
TAAPH0 SDAF 230-Style Four-Bolt Pillow Blocks	194
TAAPH1 SDAF 231-Style Four-Bolt Pillow Blocks	195
TAAPG SN-Style Four-Bolt Pillow Blocks	196
TAASN 3000 Series Four-Bolt Pillow Block	197
TAASN 3100 Series Four-Bolt Pillow Block	199
DAAC Piloted Flange Cartridges	201
TAAFC Square Piloted Flange Cartridges	202
TAAFB Square Flange Blocks	203
TAFNL Series Square Flange Blocks	204
DAAF Square Flange Blocks	205
TAAFK 9000 Series Square Flange Blocks	206
TAAMC Cartridge Blocks	207

TA/DV TAA/DAA SERIES

TA/TAA SERIES

TA series housed unit bearings are a direct drop-in replacement for SAF/SN split-cap housing dimensions.

DV/DAA SERIES

DV series housed units are a drop-in replacement for common American set screw mounted units.



Fig. 50. TA/DV series taper adapter insert.



Fig. 51. Double nut tapered adapter insert.

YOU HAVE CHOICES

For the TA/TAA and DV/DAA series, you can select from many seal options and housing styles, which are shown on page 15.

HOUSINGS

- Two-bolt pillow blocks
- Four-bolt pillow blocks
- Flange blocks
- Piloted flange cartridges
- Cartridge blocks

SEALS

- Labyrinth: DuPont™ Teflon® (T)
- Triple-lip: nitrile rubber (M), urethane (O) and Viton® (N)
- Double-lip: nitrile rubber (B) and Viton (C)
- Steel and urethane closed-end covers (CS)
- Steel and urethane open-end covers (CK) with:
 - DuPont Teflon (T)
 - Triple-lip seal (DR)
 - V-ring seal (VR)

DAAP TWO-BOLT PILLOW BLOCKS

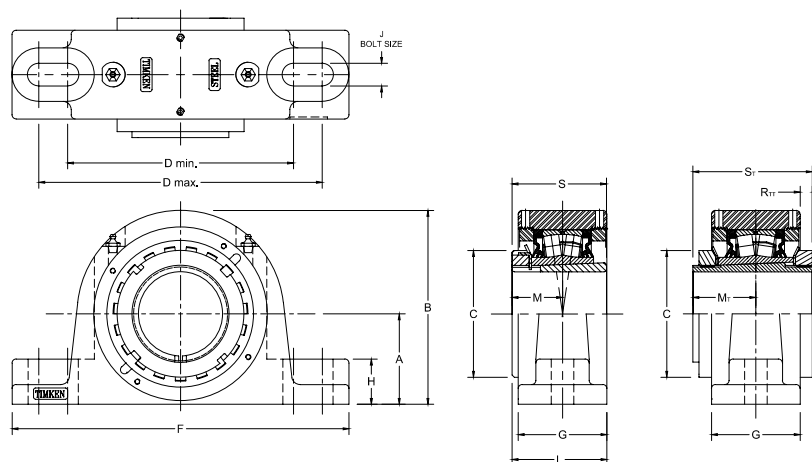

Bearing Part No. ⁽¹⁾	Shaft Dia.	Bearing No.	A	B	C	D min.	D max.	F	G	H	J	L	M	M _T	R _T	S	S _T	Wt.	
	mm in.		mm in.	mm in.	mm in.	mm in.	mm in.	mm in.	mm in.	mm in.	mm in.	mm in.	mm in.	mm in.	mm in.	mm in.	mm in.	kg lbs.	
DAAP09K107S	1 7/16 in.	22209	47.8 1.88	98.6 3.88	65.0 2.56	119.1 4.69	152.4 6.00	174.8 6.88	53.3 2.10	25.4 1.00	12 1/2	57.4 2.26	30.7 1.21	34.2 1.34	4.5 0.18	50.3 1.98	65.33 2.57	4.5 10	
DAAP09K108S	1 1/2 in.	22209	54.1 2.13	104.9 4.13	65.0 2.56	119.1 4.69	165.1 6.50	200.2 7.88	53.3 2.10	25.4 1.00	12 1/2	57.4 2.26	30.7 1.21			50.3 1.98		4.5 10	
DAAP09K040S	40 mm																		
DAAP10K111S	1 11/16 in.	22210	54.1 2.13	114.3 4.50	70.1 2.76	144.8 5.70	165.1 6.50	200.2 7.88	54.9 2.16	31.8 1.25	12 1/2	61.0 2.40	33.5 1.32	37.6 1.48	6.3 0.25	55.1 2.17	71.33 2.81	5.0 11	
DAAP10K112S	1 3/4 in.	22210	57.2 2.25	117.3 4.62	70.1 2.76	158.8 6.25	180.8 7.12	225.6 8.88	54.9 2.16	31.8 1.25	16 5/8	61.0 2.40	33.5 1.32			55.1 2.17		5.0 11	
DAAP10K045S	45 mm																		
DAAP11K115S	1 15/16 in.	22211	57.2 2.25	123.4 4.86	74.9 2.95	152.4 6.00	181.1 7.13	225.6 8.88	61.7 2.43	31.8 1.25	16 5/8	66.5 2.62	35.6 1.40	39.1 1.54	6.4 0.25	58.9 2.32	76.33 3.01	5.9 13	
DAAP11K200S	2 in.																		
DAAP11K050S	50 mm																		
DAAP13K203S	2 3/16 in.	22213	63.5 2.50	138.9 5.47	85.1 3.35	165.1 6.50	200.0 7.87	244.6 9.63	70.6 2.78	32.8 1.29	16 5/8	74.9 2.95	39.6 1.56	43.7 1.72	3.8 0.15	65.0 2.56	82.83 3.26	9.1 20	
DAAP13K204S	2 1/4 in.																		
DAAP13K060S	60 mm																		
DAAP15K207S	2 7/16 in.	22215	69.9 2.75	149.9 5.90	98.0 3.86	174.8 6.88	219.2 8.63	260.4 10.25	68.6 2.70	35.1 1.38	16 5/8	78.2 3.08	43.9 1.73	48.7 1.92	9.3 0.37	73.4 2.89	92.33 3.64	11.3 25	
DAAP15K208S	2 1/2 in.																		
DAAP15K065S	65 mm																		
DAAP17K215S	2 15/16 in.	22217	82.6 3.25	173.2 6.82	110.0 4.33	200.2 7.88	244.3 9.62	295.4 11.63	76.2 3.00	35.1 1.38	20 3/4	88.1 3.47	49.8 1.96	50.2 1.98	16.0 0.63	82.0 3.23	104.33 4.12	14.5 32	
DAAP17K300S	3 in.																		
DAAP17K075S	75 mm																		
DAAP20K307S	3 7/16 in.	22220	95.3 3.75	202.7 7.98	130.0 5.12	238.3 9.38	285.8 11.25	342.9 13.50	85.9 3.38	47.8 1.88	24 7/8	101.3 3.99	58.4 2.30	63.6 2.51	15.3 0.60	97.0 3.82	121.83 4.80	25.9 57	
DAAP20K308S	3 1/2 in.																		
DAAP20K090S	90 mm																		
DAAP22K315S	3 15/16 in.	22222	108.0 4.25	223.5 8.80	145.0 5.71	255.5 10.06	317.5 12.50	362.0 14.25	100.6 3.96	38.1 1.50	24 1	113.3 4.46	63.0 2.48	65.8 2.59	14.6 0.57	104.9 4.13	130.7 5.15	30.4 67	
DAAP22K400S	4 in.																		
DAAP22K100S	100 mm																		

⁽¹⁾Double-nut (TAA/DAA) part number shown. Single-nut (TA/DV) version available upon request.

TAAPA SAF-STYLE TWO-BOLT PILLOW BLOCKS

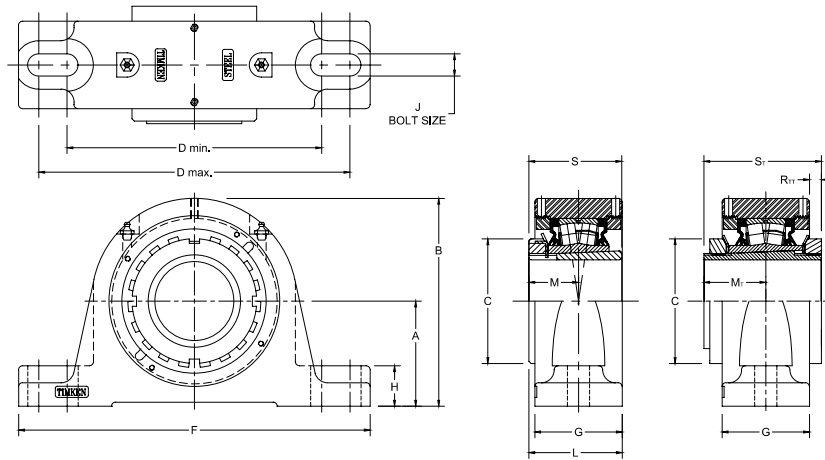

Bearing Part No. ⁽¹⁾	Shaft Dia.	Bearing No.	A	B	C	D min.	D max.	F	G	H	J	L	M	M _T	R _{TT}	S	S _T	Wt.	
	mm in.		mm in.	mm in.	mm in.	mm in.	mm in.	mm in.	mm in.	mm in.	mm in.	mm in.	mm in.	mm in.	mm in.	mm in.	mm in.	mm in.	kg lbs.
TAAPA09K107S	1 1/8 in.	22209	57.2	108.0	65.0	158.8	177.8	209.6	53.3	29.0	12	57.4	30.7	34.2	4.6	50.3	65.33	4.5	
TAAPA09K108S	1 1/2 in.		2.25	4.25	2.56	6.25	7.00	8.25	2.10	1.14	1/2	2.26	1.21	1.34	0.18	1.98	2.57	10	
TAAPA09K040S	40 mm																		
TAAPA10K111S	1 1/16 in.	22210	63.5	123.7	70.1	165.1	177.8	209.6	54.9	31.8	12	61.0	33.5	37.6	6.3	55.1	71.33	5.9	
TAAPA10K112S	1 3/4 in.		2.50	4.87	2.76	6.50	7.00	8.25	2.16	1.25	1/2	2.40	1.32	1.48	0.25	2.17	2.81	13	
TAAPA10K045S	45 mm																		
TAAPA11K115S	1 5/16 in.	22211	69.9	135.4	74.9	165.1	221.0	251.0	60.5	31.8	16	65.8	35.6	39.1	7.0	58.9	76.33	7.7	
TAAPA11K200S	2 in.		2.75	5.33	2.95	6.50	8.70	9.88	2.38	1.25	5/8	2.59	1.40	1.54	0.27	2.32	3.01	17	
TAAPA11K050S	50 mm																		
TAAPA13K203S	2 3/16 in.	22213	76.2	151.1	85.1	182.9	241.3	269.5	68.6	31.2	16	73.9	39.6	43.7	4.8	65.0	82.83	10.4	
TAAPA13K204S	2 1/4 in.		3.00	5.95	3.35	7.20	9.50	10.61	2.70	1.23	5/8	2.91	1.56	1.72	0.19	2.56	3.26	23	
TAAPA13K060S	60 mm																		
TAAPA15K207S	2 7/16 in.	22215	82.6	163.3	98.0	200.2	244.6	276.4	68.6	31.8	16	78.2	43.9	48.7	9.3	72.9	92.33	12.2	
TAAPA15K208S	2 1/2 in.		3.25	6.43	3.86	7.88	9.63	10.88	2.70	1.25	5/8	3.08	1.73	1.92	0.37	2.87	3.64	27	
TAAPA15K065S	65 mm																		
TAAPA16K211S	2 11/16 in.	22216	88.9	176.7	104.7	228.6	279.4	330.2	72.6	31.8	20	83.8	47.5	51.7	11.3	77.8	99.33	13.6	
TAAPA16K212S	2 3/4 in.		3.50	6.96	4.12	9.00	11.00	13.00	2.86	1.25	3/4	3.30	1.87	2.04	0.45	3.06	3.91	30	
TAAPA16K070S	70 mm																		
TAAPA17K215S	2 5/16 in.	22217	95.3	185.9	110.0	241.3	279.4	320.8	76.2	33.8	20	88.1	49.8	50.2	16.0	82.0	104.33	15.0	
TAAPA17K300S	3 in.		3.75	7.32	4.33	9.50	11.00	12.63	3.00	1.33	3/4	3.47	1.96	1.98	0.63	3.23	4.12	33	
TAAPA17K075S	75 mm																		
TAAPA18K303S	3 3/16 in.	22218	101.6	203.1	119.6	254.0	298.5	349.3	79.8	41.3	20	91.9	52.0	56.6	12.3	86.0	108.83	22.2	
TAAPA18K304S	3 1/4 in.		4.00	8.00	4.71	10.00	11.75	13.75	3.14	1.63	3/4	3.62	2.05	2.23	0.49	3.39	4.28	49	
TAAPA18K080S	80 mm																		
TAAPA20K307S	3 7/16 in.	22220	114.3	219.2	130.0	276.4	333.5	374.7	86.9	41.4	24	102.4	58.4	63.6	14.8	97.0	121.83	29.5	
TAAPA20K308S	3 1/2 in.		4.50	8.63	5.12	10.88	13.13	14.75	3.42	1.63	7/8	4.03	2.30	2.51	0.58	3.82	4.80	65	
TAAPA20K090S	90 mm																		
TAAPA22K315S	3 5/16 in.	22222	125.5	240.5	145.0	317.5	368.3	406.4	100.6	50.8	24	113.5	63.0	65.8	14.6	104.9	130.7	38.1	
TAAPA22K400S	4 in.		4.94	9.47	5.71	12.50	14.50	16.00	3.96	2.00	7/8	4.47	2.48	2.59	0.57	4.13	5.15	84	
TAAPA22K100S	100 mm																		
TAAPA26K407S	4 7/16 in.	22226	152.4	284.0	165.1	362.0	400.1	444.5	128.0	51.8	24	135.9	71.9	76.6	9.1	120.9	149.65	61.7	
TAAPA26K408S	4 1/2 in.		6.00	11.18	6.50	14.25	15.75	17.50	5.04	2.04	1	5.35	2.83	3.01	0.36	4.76	5.89	136	
TAAPA26K115S	115 mm																		
TAAPA28K415S	4 5/16 in.	22228	152.4	297.2	180.1	384.3	441.3	499.9	108.0	51.8	30	120.4	77.5	85.2	22.0	131.1	161.15	61.8	
TAAPA28K500S	5 in.		6.00	11.7	7.09	15.13	17.38	19.68	4.25	2.04	1 1/4	4.74	3.05	3.35	0.86	5.16	6.34	136	
TAAPA28K125S	125 mm																		

⁽¹⁾Double-nut (TAA/DAA) part number shown. Single-nut (TA/DV) version available upon request.

TAAPN SN-STYLE TWO-BOLT PILLOW BLOCKS

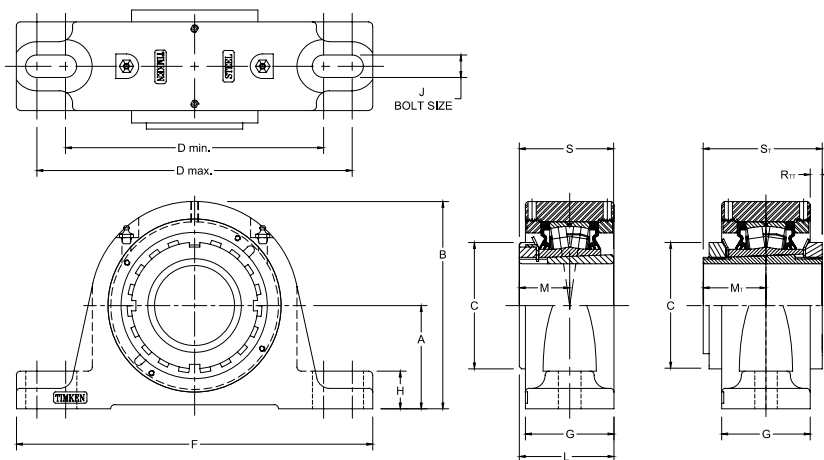

Bearing Part No. ⁽¹⁾	Shaft Dia.	Bearing No.	A	B	C	D min.	D max.	F	G	H	J	L	M	M _T	R _{TT}	S	S _T	Wt.
			mm in.	mm in.	mm in.	mm in.	mm in.	mm in.	mm in.	mm in.	mm in.	mm in.	mm in.	mm in.	mm in.	mm in.	mm in.	mm in.
TAAPN09K107S	1 7/16 in.	22209	60.0	108.0	65.0	158.8	177.8	209.6	53.3	29.0	12	57.4	30.7	34.2	4.6	50.3	65.33	4.5
TAAPN09K108S	1 1/2 in.		2.362	4.25	2.56	6.25	7.00	8.25	2.10	1.14	1/2	2.26	1.21	1.34	0.18	1.98	2.57	10
TAAPN09K040S	40 mm																	
TAAPN10K111S	1 15/16 in.	22210	60.0	120.1	70.1	165.1	177.8	209.6	54.9	28.2	12	61.0	33.5	37.6	6.3	55.1	71.33	5.9
TAAPN10K112S	1 3/4 in.		2.362	4.73	2.76	6.50	7.00	8.25	2.16	1.11	1/2	2.40	1.32	1.48	0.25	2.17	2.81	13
TAAPN10K045S	45 mm																	
TAAPN11K115S	1 5/16 in.	22211	69.9	135.4	74.9	165.1	221.0	251.0	60.5	31.8	16	65.8	35.6	39.1	7.0	58.9	76.33	7.7
TAAPN11K200S	2 in.		2.75	5.33	2.95	6.50	8.70	9.88	2.38	1.25	5/8	2.59	1.40	1.54	0.27	2.32	3.01	17
TAAPN11K050S	50 mm																	
TAAPN12K055S	55 mm	22212	70.0	140.5	79.8	177.8	219.2	254.0	60.5	31.8	16	67.6	37.6	41.1	7.0	62.0	78.33	9.1
TAAPN13K203S	2 3/16 in.	22213	80.0	154.9	85.1	182.9	241.3	269.5	68.6	35.1	16	73.9	39.6	43.7	4.8	65.0	82.83	10.4
TAAPN13K204S	2 1/4 in.		3.15	6.10	3.35	7.20	9.50	10.61	2.70	1.38	5/8	2.91	1.56	1.72	0.19	2.56	3.26	23
TAAPN13K060S	60 mm																	
TAAPN15K207S	2 7/16 in.	22215	80.0	160.8	98.0	200.2	244.6	276.4	68.6	29.2	16	78.2	43.9	48.7	9.3	72.9	92.33	12.2
TAAPN15K208S	2 1/2 in.		3.15	6.33	3.86	7.88	9.63	10.88	2.70	1.15	5/8	3.08	1.73	1.92	0.37	2.87	3.64	27
TAAPN15K065S	65 mm																	
TAAPN16K211S	2 11/16 in.	22216	95.0	180.3	104.6	235.0	266.7	315.0	72.6	31.8	20	83.8	47.5	51.7	11.3	78.0	99.33	13.6
TAAPN16K212S	2 3/4 in.		3.74	7.10	4.12	9.25	10.50	12.40	2.86	1.25	3/4	3.30	1.87	2.04	0.45	3.07	3.91	30
TAAPN16K070S	70 mm																	
TAAPN17K215S	2 15/16 in.	22217	95.3	185.9	110.0	241.3	279.4	320.8	76.2	33.8	20	88.1	49.8	50.2	16.0	82.0	104.33	15.0
TAAPN17K300S	3 in.		3.75	7.32	4.33	9.50	11.00	12.63	3.00	1.33	3/4	3.47	1.96	1.98	0.63	3.23	4.12	33
TAAPN17K075S	75 mm																	
TAAPN18K080S	80 mm	22218	100.0	195.3	119.6	285.8	295.4	346.2	79.8	38.9	20	91.7	52.1	56.6	12.3	86.1	108.83	22.2
TAAPN18K303S	3 3/16 in.		3.937	7.69	4.71	11.25	11.63	13.63	3.14	1.53	3/4	3.61	2.05	2.23	0.49	3.39	4.28	49
TAAPN18K304S	3 1/4 in.																	
TAAPN19K085S	85 mm	22219	112.0	212.3	124.7	285.8	295.4	346.2	82.8	38.9	20	96.0	54.6	59.2	13.2	89.9	113.83	23.1
TAAPN20K307S	3 7/16 in.	22220	112.0	216.9	130.0	276.4	333.5	374.7	86.9	38.9	24	102.4	58.4	63.6	14.8	97.0	121.83	29.5
TAAPN20K308S	3 1/2 in.		4.409	8.54	5.12	10.88	13.13	14.75	3.42	1.53	7/8	4.03	2.30	2.51	0.58	3.82	4.80	65
TAAPN20K090S	90 mm																	
TAAPN22K315S	3 15/16 in.	22222	125.0	240.5	145.0	317.5	368.3	406.4	100.6	50.8	24	113.5	63.0	65.8	14.6	104.9	130.7	38.1
TAAPN22K400S	4 in.		4.921	9.47	5.71	12.50	14.50	16.00	3.96	2.00	7/8	4.47	2.48	2.59	0.57	4.13	5.15	84
TAAPN22K100S	100 mm																	
TAAPN24K403S	4 3/16 in.	22224	140.0	262.9	154.4	344.4	355.6	409.7	97.8	50.8	24	116.1	67.1	71.6	18.7	112.0	139.15	49.9
TAAPN24K404S	4 1/4 in.		5.512	10.35	6.08	13.56	14.00	16.13	3.85	2.00	7/8	4.57	2.64	2.82	0.73	4.41	5.48	110
TAAPN24K110S	110 mm																	
TAAPN26K407S	4 7/16 in.	22226	150.0	281.7	165.1	367.3	400.1	444.5	128.0	49.3	24	135.9	71.9	76.6	9.1	120.9	149.65	61.7
TAAPN26K408S	4 1/2 in.		5.906	11.09	6.50	14.46	15.75	17.50	5.04	1.94	1	5.35	2.83	3.01	0.36	4.76	5.89	136
TAAPN26K115S	115 mm																	
TAAPN28K415S	4 15/16 in.	22228	150.0	288.5	180.1	384.3	441.5	499.9	108.0	49.3	30	120.4	77.5	85.2	22.0	131.1	161.15	61.8
TAAPN28K500S	5 in.		5.906	11.36	7.09	15.13	17.38	19.68	4.25	1.94	1 1/4	4.74	3.05	3.35	0.86	5.16	6.34	136
TAAPN28K125S	125 mm																	

⁽¹⁾Double-nut (TAA/DAA) part number shown. Single-nut (TA/DV) version available upon request.

TAASD SPECIAL DUTY-STYLE TWO-BOLT PILLOW BLOCKS

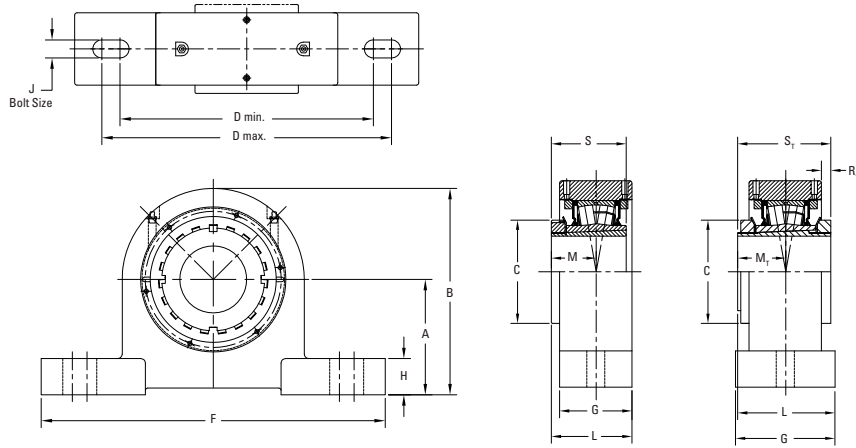

Bearing Part No. ⁽¹⁾	Shaft Dia.	Bearing No.	A	B	C	D min.	D max.	F	G	H	J	L	M	M _T	R _{1T}	S	S ₁	Wt.
	mm in.		mm in.	mm in.	mm in.	mm in.	mm in.	mm in.	mm in.	mm in.	mm in.	mm in.	mm in.	mm in.	mm in.	mm in.	mm in.	kg lbs.
TAASD09K107S	1 7/8 in.	22209	73.2	124.0	65.0	174.8	193.8	228.6	51.7	29.0	M12	56.6	30.7	33.3	6.20	50.2	65.3	6
TAASD09K108S	1 1/2 in.		2.88	4.88	2.56	6.88	7.63	9.00	2.03	1.14	1/2	2.23	1.21	1.31	0.24	1.98	2.42	14
TAASD09K040S	40 mm																	
TAASD10K111S	1 13/16 in.	22210	79.5	139.7	70.1	192.0	201.7	241.3	51.7	31.8	M12	59.4	33.5	36.3	9.20	55.0	71.3	7
TAASD10K112S	1 3/4 in.		3.13	5.50	2.76	7.56	7.94	9.50	2.03	1.25	1/2	2.34	1.32	1.43	0.36	2.17	2.64	16
TAASD10K045S	45 mm																	
TAASD11K115S	1 15/16 in.	22211	82.6	148.1	74.9	209.6	235.0	279.4	57.5	31.8	M16	64.3	35.6	39.4	8.20	58.9	76.3	9
TAASD11K200S	2 in.		3.25	5.83	2.95	8.25	9.25	11.00	2.26	1.25	5/8	2.53	1.40	1.55	0.32	2.32	2.80	19
TAASD11K050S	50 mm																	
TAASD13K203S	2 3/8 in.	22213	95.3	170.2	85.1	231.9	263.7	304.8	70.7	31.8	M16	75.0	39.6	42.4	5.10	65.0	82.8	13
TAASD13K204S	2 1/4 in.		3.75	6.70	3.35	9.13	10.38	12.00	2.78	1.25	3/8	2.95	1.56	1.67	0.20	2.56	3.12	30
TAASD13K060S	60 mm																	
TAASD15K207S	2 7/8 in.	22215	101.6	182.4	98.0	254.0	292.1	336.6	70.7	31.8	M20	79.3	43.9	47.0	10.0	72.9	92.3	15
TAASD15K208S	2 1/2 in.		4.00	7.18	3.86	10.00	11.50	13.25	2.78	1.25	3/4	3.12	1.73	1.85	0.39	2.87	3.46	34
TAASD15K065S	65 mm																	
TAASD17K215S	2 15/16 in.	22217	120.7	211.3	110.0	279.4	317.5	362.0	75.7	39.6	M20	87.6	49.8	53.6	12.9	82.0	104.3	22
TAASD17K300S	3 in.		4.75	8.32	4.33	11.00	12.50	14.25	2.98	1.56	3/4	3.45	1.96	2.11	0.51	3.23	3.92	48
TAASD17K075S	75 mm																	
TAASD18K080S	80 mm	22218	139.7	237.5	119.6	336.6	362.0	425.5	79.7	39.6	M24	91.9	52.1	56.1	12.9	86.1	108.8	28
TAASD18K303S	3 3/8 in.		5.50	9.35	4.71	13.25	14.25	16.75	3.14	1.56	3/4	3.62	2.05	2.21	0.51	3.39	4.10	62
TAASD18K304S	3 1/4 in.																	
TAASD20K307S	3 7/8 in.	22220	139.7	247.7	130.0	336.6	362.0	425.5	85.7	69.9	M24	101.3	58.4	62.6	16.4	97.0	121.8	33
TAASD20K308S	3 1/2 in.		5.50	9.75	5.12	13.25	14.25	16.75	3.38	2.75	3/4	3.99	2.30	2.46	0.65	3.82	4.60	72
TAASD20K090S	90 mm																	

⁽¹⁾Double-nut (TAA) part number shown. Single-nut (TA) version available upon request.

TAADI DI-STYLE TWO-BOLT PILLOW BLOCK

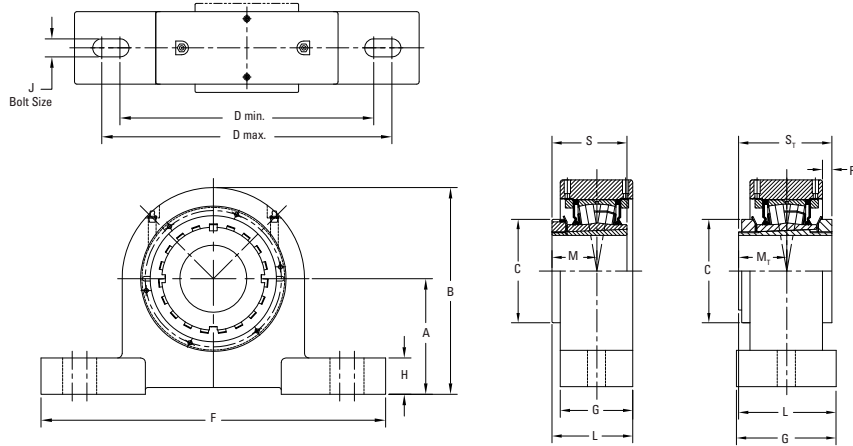

Bearing Part No. ⁽¹⁾	Shaft Dia.	Bearing No.	A	B	C	D min.	D max.	F	G	H	J	L	M	M _T	R _{TT}	S	S _T	Wt.
			mm in.	mm in.	mm in.	mm in.	mm in.	mm in.	mm in.	mm in.	mm in.	mm in.	mm in.	mm in.	mm in.	mm in.	mm in.	mm in.
TAADI09K107S	1 7/16 in.	22209	60.5 2.38	119.8 4.72	65.0 2.56	158.8 6.25	168.4 6.63	203.2 8.00	51.7 2.03	29.0 1.14	M12 ½	56.6 2.23	30.7 1.21	33.3 1.31	6.20 0.24	50.3 1.98	65.3 2.42	5 12
TAADI09K108S	1 ½ in.		66.8 2.63	127.0 5.00	65.0 2.56	174.8 6.88	193.8 7.63	228.6 9.00	51.7 2.03	31.8 1.25	M12 ½	56.6 2.23	30.7 1.21			50.3 1.98		
TAADI09K040S	40 mm																	
TAADI10K111S	1 3/8 in.	22210	66.8 2.63	127.0 5.00	70.1 2.76	174.8 6.88	193.8 7.63	228.6 9.00	51.7 2.03	31.8 1.25	M12 ½	62.1 2.45	33.5 1.32	36.3 1.43	9.2 0.36	55.1 2.17	71.3 2.64	6 13
TAADI10K112S	1 ¾ in.		73.2 2.88	138.7 5.46	70.1 2.76	187.5 7.38	201.7 7.94	254.0 10.00	51.7 2.03	31.8 1.25	M12 ½	65.3 2.57	33.5 1.32			55.1 2.17		
TAADI10K045S	45 mm																	
TAADI11K115S	1 9/16 in.	22211	73.2 2.88	138.7 5.46	74.9 2.95	187.5 7.38	201.7 7.94	254.0 10.00	57.5 2.26	31.8 1.25	M16 5/8	64.3 2.53	35.6 1.40	39.4 1.55	8.2 0.32	58.9 2.32	76.3 2.80	7 16
TAADI11K200S	2 in.																	
TAADI11K050S	50 mm																	
TAADI13K203S	2 3/8 in.	22213	76.2 3.00	151.1 5.95	85.1 3.35	203.2 8.00	235.0 9.25	279.4 11.00	70.71 2.78	31.8 1.25	M16 5/8	77.7 3.06	39.6 1.56	42.4 1.67	5.0 0.20	65.0 2.56	82.8 3.12	11 25
TAADI13K204S	2 ¼ in.		82.6 3.25	163.3 6.43	85.1 3.35	235.0 9.25	260.4 10.25	304.8 12.00	70.71 2.78	31.8 1.25	M16 5/8	82.0 3.23	43.9 1.73			72.9 2.87		
TAADI13K060S	60 mm																	
TAADI15K207S	2 7/8 in.																	
TAADI15K208S	2 ½ in.	22215	82.6 3.25	163.3 6.43	98.0 3.86	235.0 9.25	260.4 10.25	304.8 12.00	70.71 2.78	31.8 1.25	M16 5/8	82.0 3.23	43.9 1.73	47.0 1.85	9.9 0.39	72.9 2.87	92.3 3.46	13 29
TAADI15K065S	65 mm																	
TAADI17K215S	2 9/16 in.	22217	95.3 3.75	185.9 7.32	110.0 4.33	251.0 9.88	292.1 11.50	341.8 13.46	75.7 2.98	31.8 1.25	M20 ¾	87.9 1.96	49.8 1.96	53.6 2.11	12.9 0.51	82.0 3.23	104.3 3.92	18 39
TAADI17K300S	3 in.																	
TAADI17K075S	75 mm																	
TAADI18K080S	80 mm	22218	114.3 4.50	219.2 8.63	119.6 4.71	325.4 12.81	350.8 13.81	406.4 16.00	79.7 3.14	39.6 1.56	M24 7/8	93.3 3.68	52.1 2.05	56.1 2.21	12.8 0.51	86.1 3.39	108.8 4.10	26 58
TAADI18K303S	3 3/8 in.																	
TAADI18K304S	3 ¼ in.																	
TAADI20K307S	3 7/8 in.	22220	114.3 4.50	219.2 8.63	130.0 5.12	325.4 12.81	350.8 13.81	406.4 16.00	85.7 3.38	39.6 1.56	M24 7/8	102.9 4.05	58.4 2.30	58.4 2.30	16.3 0.64	97.0 3.82	121.8 4.60	27 60
TAADI20K308S	3 ½ in.																	
TAADI20K090S	90 mm																	

⁽¹⁾Double-nut (TAA) part number shown. Single-nut (TA) version available upon request.

TAAPKT 9000 SERIES TWO-BOLT PILLOW BLOCKS

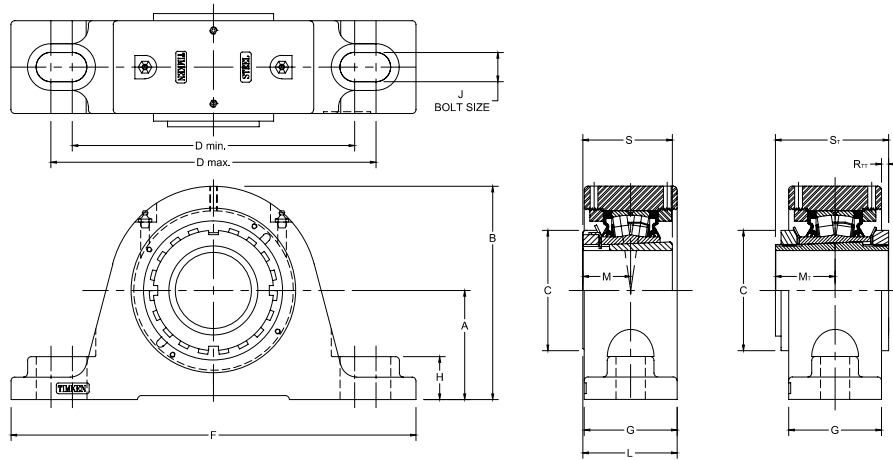

Bearing Part No. ⁽¹⁾	Shaft Dia.	Bearing No.	A	B	C	D min.	D max.	F	G	H	J	L	M	M _T	R _{TT}	S	S _T	Wt.
	mm in.		mm in.	mm in.	mm in.	mm in.	mm in.	mm in.	mm in.	mm in.	mm in.	mm in.	mm in.	mm in.	mm in.	mm in.	mm in.	kg lbs.
TAAPKT13K203S	2 3/16 in.	22213	76.2	153.7	85.1	194.6	223.0	285.8	73.7	35.1	20	76.5	36.6	43.7	2.3	65.0	82.83	10.0
TAAPKT13K204S	2 1/4 in.		3.00	6.05	3.35	7.66	8.78	11.25	2.90	1.38	3/4	3.01	1.56	1.72	0.09	2.56	3.26	22
TAAPKT13K060S	60 mm																	
TAAPKT15K207S	2 7/16 in.	22215	88.9	173.7	98.0	230.1	265.2	330.2	75.7	35.1	24	81.8	43.9	48.7	5.8	72.9	92.33	12.7
TAAPKT15K208S	2 1/2 in.		3.50	6.84	3.86	9.06	10.44	13.00	2.98	1.38	7/8	3.22	1.73	1.92	0.23	2.87	3.64	28
TAAPKT15K065S	65 mm																	

⁽¹⁾Double-nut (TAA/DAA) part number shown. Single-nut (TA/DV) version available upon request.

DAAPF FOUR-BOLT PILLOW BLOCKS

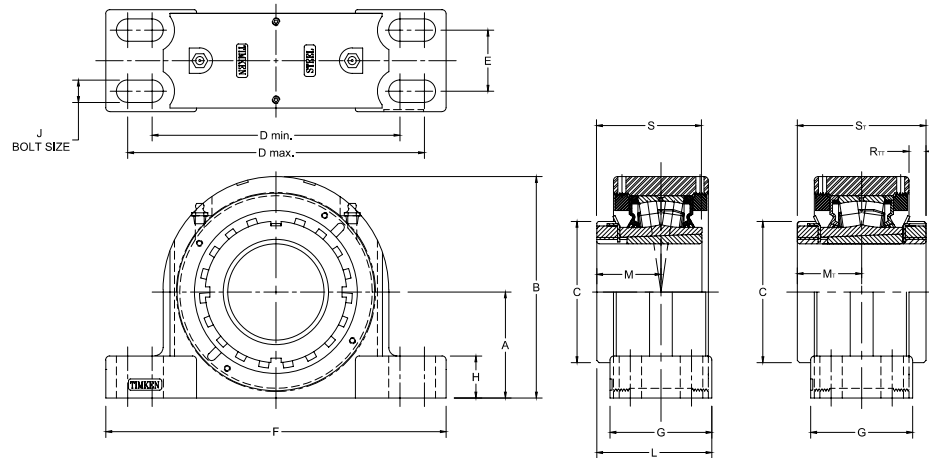

Bearing Part No. ⁽¹⁾	Shaft Dia.	Bearing No.	A	B	C	D min.	D max.	E	F	G	H	J	L	M	M _T	R _T	S	S _T	Wt.
	mm in.		mm in.	mm in.	mm in.	mm in.	mm in.	mm in.	mm in.	mm in.	mm in.	mm in.	mm in.	mm in.	mm in.	mm in.	mm in.	mm in.	kg lbs.
DAAPF17K215S	2 1/16 in.	22217	82.6	172.5	110.0	193.0	231.1	47.8	265.2	79.5	32.8	16	86.6	49.8	50.2	13.2	82.0	104.33	23.1
DAAPF17K300S	3 in.		3.25	6.79	4.33	7.60	9.10	1.88	10.44	3.13	1.29	5/8	3.41	1.96	1.98	0.52	3.23	4.12	51
DAAPF17K075S	75 mm																		
DAAPF20K307S	3 7/16 in.	22220	95.3	200.2	130.0	225.6	276.4	50.8	312.4	95.3	39.6	20	101.3	58.4	63.6	13.8	97.0	121.83	31.8
DAAPF20K308S	3 1/2 in.		3.75	7.88	5.12	8.88	10.88	2.00	12.30	3.75	1.56	3/4	3.99	2.30	2.51	0.54	3.82	4.80	70
DAAPF20K090S	90 mm																		
DAAPF22K315S	3 15/16 in.	22222	108.0	223.0	145.0	276.4	339.9	57.2	378.0	109.5	35.6	20	110.7	63.0	65.8	17.3	104.9	130.7	38.6
DAAPF22K400S	4 in.		4.25	8.78	5.71	10.88	13.38	2.25	14.88	4.31	1.40	3/4	4.36	2.48	2.59	0.68	4.13	5.15	85
DAAPF22K100S	100 mm																		
DAAPF26K407S	4 7/16 in.	22226	120.7	250.7	165.1	302.3	368.3	63.5	409.7	120.7	40.1	20	123.7	71.9	76.6	16.7	120.1	149.65	62.1
DAAPF26K408S	4 1/2 in.		4.75	9.87	6.50	11.90	14.50	2.50	16.13	4.75	1.58	3/4	4.87	2.83	3.01	0.66	4.73	5.89	137
DAAPF26K115S	115 mm																		

⁽¹⁾Double-nut (TAA/DAA) part number shown. Single-nut (TA/DV) version available upon request.

TAAPK 9000 SERIES FOUR-BOLT PILLOW BLOCKS

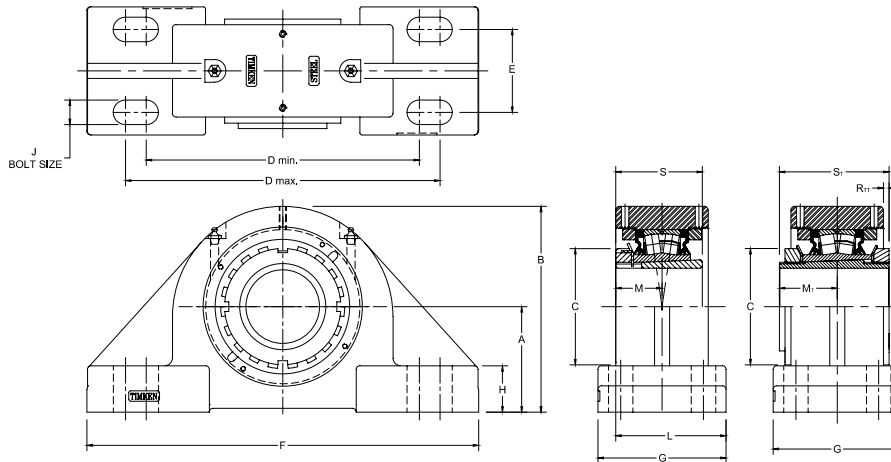

Bearing Part No. ⁽¹⁾	Shaft Dia.	Bearing No.	A	B	C	D min.	D max.	E	F	G	H	J	L	M	M _T	R _{T1}	S	S _T	Wt.
	mm in.		mm in.	mm in.	mm in.	mm in.	mm in.	mm in.	mm in.	mm in.	mm in.	mm in.	mm in.	mm in.	mm in.	mm in.	mm in.	mm in.	kg lbs.
TAAPK15K207S	2 7/16 in.	22215	88.9	173.5	98.0	230.1	265.2	69.9	330.2	108.0	39.1	20	98.0	43.9	48.7	4.7	72.9	92.33	13.2
TAAPK15K208S	2 1/2 in.		3.50	6.83	3.86	9.06	10.44	2.75	13.00	4.25	1.54	3/4	3.86	1.73	1.92	0.18	2.87	3.64	29
TAAPK15K065S	65 mm																		
TAAPK17K215S	2 15/16 in.	22217	101.6	201.2	110.0	274.6	309.6	76.2	381.0	120.7	38.1	20	110.2	49.8	50.2	9.7	82.0	104.33	16.8
TAAPK17K300S	3 in.		4.00	7.92	4.33	10.81	12.19	3.00	15.00	4.75	1.50	3/4	4.34	1.96	1.98	0.38	3.23	4.12	37
TAAPK17K075S	75 mm																		
TAAPK20K307S	3 7/16 in.	22220	127.0	239.8	130.0	317.5	355.6	88.9	425.5	139.7	41.4	22	128.3	58.4	63.6	8.4	97.0	121.83	31.8
TAAPK20K308S	3 1/2 in.		5.00	9.44	5.12	12.50	14.00	3.50	16.75	5.50	1.63	7/8	5.05	2.30	2.51	0.33	3.82	4.80	70
TAAPK20K090S	90 mm																		
TAAPK22K315S	3 15/16 in.	22222	146.1	273.8	145.0	354.1	395.2	101.6	469.9	158.8	45.7	24	138.2	63.0	65.8	14.1	104.9	130.7	39.5
TAAPK22K400S	4 in.		5.75	10.78	5.71	13.94	15.56	4.00	18.50	6.25	1.80	1	5.44	2.48	2.59	0.56	4.13	5.15	87
TAAPK22K100S	100 mm																		
TAAPK26K407S	4 7/16 in.	22226	155.6	283.2	165.1	387.4	425.5	108.0	514.4	171.5	50.8	24	157.5	71.9	76.6	15.9	120.9	149.65	61.7
TAAPK26K408S	4 1/2 in.		6.125	11.15	6.50	15.25	16.75	4.25	20.25	6.75	2.00	1 1/8	6.20	2.83	3.01	0.63	4.76	5.89	136
TAAPK26K115S	115 mm																		

⁽¹⁾Double-nut (TAA/DAA) part number shown. Single-nut (TA/DV) version available upon request.

TAA4SD SPECIAL DUTY-STYLE FOUR-BOLT PILLOW BLOCK

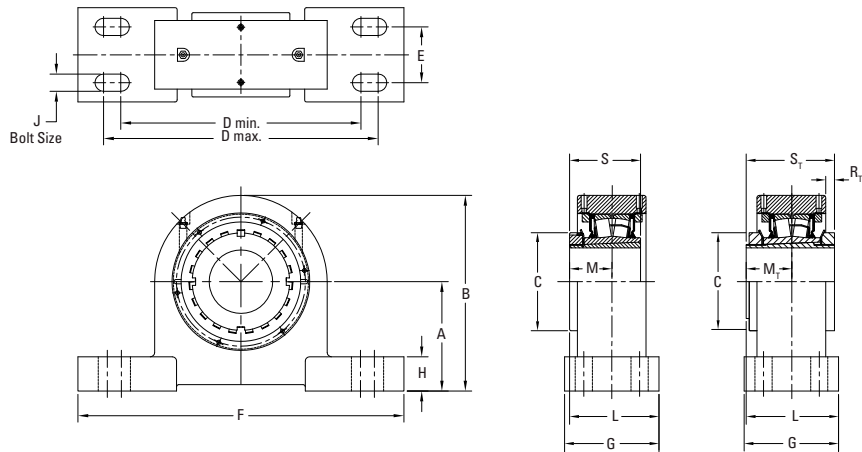

Bearing Part No. ⁽¹⁾	Shaft Dia.	Bearing No.	A	B	C	D min.	D max.	E	F	G	H	J	L	M	M _T	R _{TT}	S	S _T	Wt.
			mm in.	mm in.	mm in.	mm in.	mm in.	mm in.	mm in.	mm in.	mm in.	mm in.	mm in.	mm in.	mm in.	mm in.	mm in.	mm in.	mm in.
TAA4SD15K207S	2 7/16 in.	22215	101.6	182.1	98.04	251.0	295.4	63.5	336.6	103.4	31.8	M16	98.7	43.9	47.0	8.60	72.9	87.9	18
TAA4SD15K208S	2 1/2 in.		4.00	7.71	3.86	9.88	11.63	2.5	13.25	4.07	1.25	5/8	3.89	1.73	1.85	0.34	2.87	3.46	39
TAA4SD15K065S	65 mm																		
TAA4SD17K215S	2 15/16 in.	22217	120.7	211.3	110.0	276.4	320.8	69.9	362.0	109.8	31.8	M16	108.5	49.8	53.6	11.9	82.0	99.6	24
TAA4SD17K300S	3 in.		4.75	8.32	4.33	10.88	12.63	2.75	14.25	4.32	1.25	5/8	4.27	1.96	2.11	0.47	3.23	3.92	52
TAA4SD17K075S	75 mm																		
TAA4SD20K307S	3 7/16 in.	22220	139.7	254.0	130.0	330.2	368.3	82.56	425.5	126.5	39.6	M20	119.4	56.1	56.1	15.5	97.0	116.8	39
TAA4SD20K308S	3 1/2 in.		5.50	10	5.12	13.00	14.50	3.25	16.75	4.98	1.56	3/4	4.70	2.21	2.21	0.61	3.82	4.60	87
TAA4SD20K090S	90 mm																		
TAA4SD22K315S	3 15/16 in.	22222	161.9	285.8	145.0	381.0	406.4	82.56	482.6	133.6	44.5	M24	129.3	63.0	62.5	16.6	105.0	126.0	52
TAA4SD22K400S	4 in.		6.38	11.25	5.71	15.00	16.00	3.25	19.00	5.26	1.75	7/8	5.09	2.48	2.46	0.66	4.13	4.96	115
TAA4SD22K100S	100 mm																		
TAA4SD26K407S	4 7/16 in.	22226	184.2	317.5	165.0	393.7	444.5	88.9	508.0	140.0	50.8	M24	143.8	71.9	73.8	20.1	121.0	143.8	67
TAA4SD26K408S	4 1/2 in.		7.25	12.50	6.50	15.50	17.50	3.5	20.00	5.51	2.00	7/8	5.66	2.83	2.91	0.79	4.76	5.66	148
TAA4SD26K115S	115 mm																		
TAA4SD28K415S	4 15/16 in.	22228	190.5	342.9	180.0	450.9	501.7	95.3	584.2	152.7	50.8	M24	155.7	77.5	79.3	10.5	131.0	154.9	89
TAA4SD28K500S	5 in.		7.50	13.50	7.09	17.75	19.75	3.75	23.00	6.01	2.00	1	6.13	3.05	3.12	0.41	5.16	6.10	196
TAA4SD28K125S	125 mm																		
TAA4SD32K140S	140 mm	23132	228.6	400.1	210.0	543.1	600.2	127.0	679.5	190.8	63.5	M24	185.8	-	90.5	19.1	-	185.0	150
TAA4SD32K506S	5 3/16 in.		9.00	15.75	8.27	21.38	23.63	5.00	26.75	7.51	2.50	1 1/8	7.32		3.56	0.75		7.28	331
TAA4SD32K507S	5 7/16 in.																		
TAA4SD32K508S	5 1/2 in.	23134	228.6	400.1	220.0	543.1	600.2	127.0	679.5	190.8	63.5	M24	190.1	-	94.7	15.0	-	187.5	151
TAA4SD34K150S	150 mm		9.00	15.75	8.66	21.38	23.63	5.00	26.75	7.51	2.50	1 1/8	7.49		3.73	0.59		7.38	332
TAA4SD34K513S	5 13/16 in.																		
TAA4SD34K514S	5 7/8 in.																		
TAA4SD34K515S	5 15/16 in.																		
TAA4SD34K600S	6 in.																		

⁽¹⁾Double-nut (TAA) part number shown. Single-nut (TA) version available upon request.

⁽²⁾Insert size 23132K and above come standard with double nut tapered adapter.

Continued on next page.

TAA4SD SPECIAL DUTY-STYLE FOUR-BOLT PILLOW BLOCK – continued

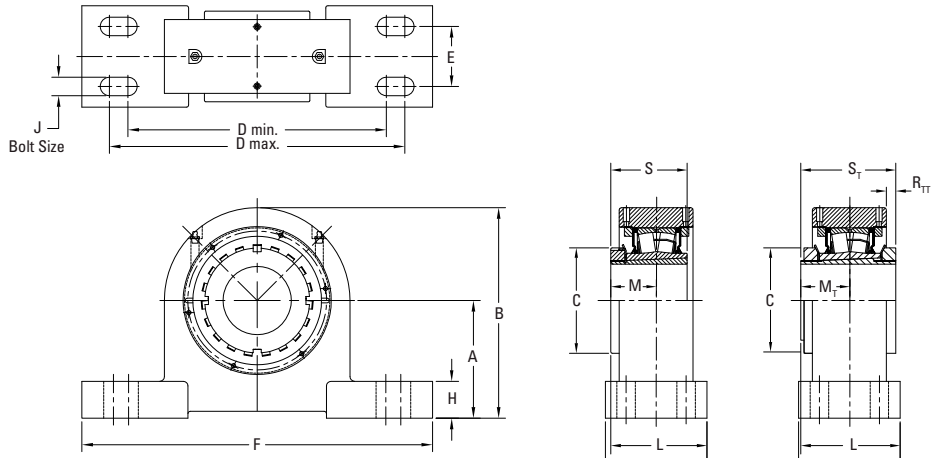

Continued from previous page.

Bearing Part No. ⁽¹⁾	Shaft Dia.	Bearing No.	A	B	C	D min.	D max.	E	F	G	H	J	L	M	M _T	R _T	S	S _T	Wt.
	mm in.		mm in.	mm in.	mm in.	mm in.	mm in.	mm in.	mm in.	mm in.	mm in.	mm in.	mm in.	mm in.	mm in.	mm in.	mm in.	mm in.	kg lbs.
TAA4SD36K160S	160 mm	23136	285.8 11.25	501.7 19.75	230.0 9.06	698.5 27.50	774.7 30.50	139.70 5.50	873.3 34.38	223.5 8.80	69.9 2.75	M36 1½	210.8 8.30	-	99.0 3.90	15.8 0.62	-	196.7 7.74	270 596
TAA4SD36K605S	6 5/16 in.																		
TAA4SD36K606S	6 3/8 in.																		
TAA4SD36K607S	6 7/8 in.																		
TAA4SD36K608S	6 1/2 in.																		
TAA4SD38K170S	170 mm	23138	285.8 11.25	501.7 19.75	240 9.45	698.5 27.50	774.7 30.50	139.70 5.50	873.3 34.38	223.5 8.80	69.9 2.75	M36 1½	216.6 8.53	-	104.8 4.13	17.0 0.67	-	207.6 8.17	273 603
TAA4SD38K613S	6 9/16 in.																		
TAA4SD38K614S	6 7/8 in.																		
TAA4SD38K615S	6 15/16 in.																		
TAA4SD38K700S	7 in.																		
TAA4SD44K715S	200 mm	23144	317.5 12.50	558.8 22.00	280.0 11.02	774.7 30.50	863.6 34.00	152.4 6.00	984.3 38.75	260.6 10.26	85.1 3.35	M42 1¾	249.2 9.81	-	119.0 4.68	21.8 0.86	-	234.7 9.24	380 838
TAA4SD44K715S	7 13/16 in.																		
TAA4SD44K715S	7 7/8 in.																		
TAA4SD44K715S	7 15/16 in.																		
TAA4SD44K800S	8 in.																		

⁽¹⁾Insert size 23132K and above come standard with double nut tapered adapter

TAA4DI DI-STYLE FOUR-BOLT PILLOW BLOCK

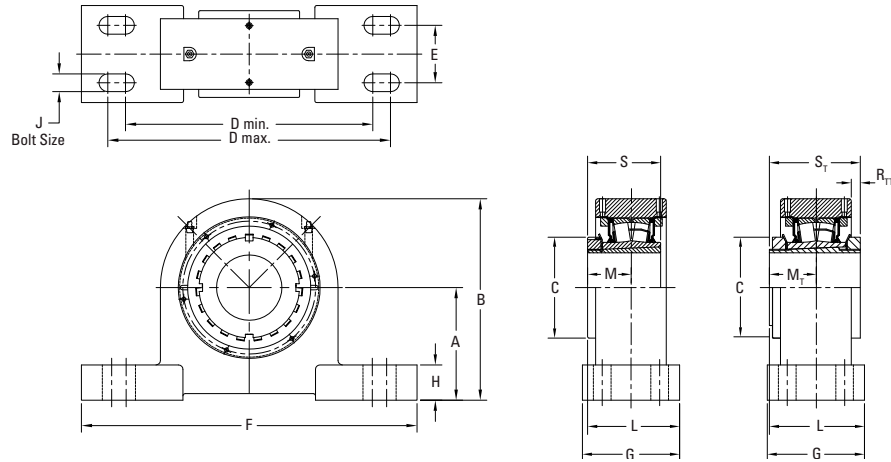

Bearing Part No. ⁽¹⁾	Shaft Dia.	Bearing No.	A	B	C	D min.	D max.	E	F	G	H	J	L	M	M _T	R _{TT}	S	S _T	Wt.
			mm in.	mm in.	mm in.	mm in.	mm in.	mm in.	mm in.	mm in.	mm in.	mm in.	mm in.	mm in.	mm in.	mm in.	mm in.	mm in.	mm in.
TAA4DI15K207S	2 7/16 in.	22215	82.6	162.1	98.0	235.0	260.4	44.5	304.8	76.2	31.8	M12	78.9	43.9	47.0	8.60	72.9	92.3	14
TAA4DI15K208S	2 1/2 in.		3.25	6.38	3.86	9.20	10.25	1.75	12.00	3.00	1.25	1/2	3.11	1.73	1.85	0.34	2.87	3.46	30
TAA4DI15K065S	65 mm																		
TAA4DI17K215S	2 9/16 in.	22217	95.3	185.7	110.0	250.8	292.1	47.6	341.4	88.9	31.8	M16	94.2	49.8	53.6	11.9	82.0	104.3	19
TAA4DI17K300S	3 in.		3.75	7.32	4.33	9.88	11.50	1.88	13.44	3.50	1.25	5/8	3.71	1.96	2.11	0.47	3.23	3.92	42
TAA4DI17K075S	75 mm																		
TAA4DI20K307S	3 7/16 in.	22220	114.3	220.4	130.0	325.4	350.8	50.8	406.4	95.3	39.6	M20	106.0	58.4	56.1	15.5	97.0	108.8	29
TAA4DI20K308S	3 1/2 in.		4.50	8.68	5.12	12.81	13.81	2.00	16.00	3.75	1.56	3/4	4.18	2.30	2.21	0.61	3.82	4.10	65
TAA4DI20K090S	90 mm																		
TAA4DI22K315S	3 15/16 in.	22222	127.0	250.8	145.0	333.4	374.7	50.8	443.0	101.6	44.5	M20	113.8	63.0	62.5	16.6	105.0	121.8	40
TAA4DI22K400S	4 in.		5.00	9.88	5.71	13.13	14.75	2.00	17.44	4.00	1.75	3/4	4.48	2.48	2.46	0.66	4.13	4.60	88
TAA4DI22K100S	100 mm																		
TAA4DI26K407S	4 7/16 in.	22226	146.1	279.4	165.0	365.1	412.8	57.2	482.6	114.3	50.8	M20	122.7	71.9	73.9	20.1	121.0	121.0	54
TAA4DI26K408S	4 1/2 in.		5.75	11.00	6.50	14.38	16.25	2.25	19.00	4.50	2.00	3/4	4.83	2.83	2.91	0.79	4.76	4.76	118
TAA4DI26K115S	115 mm																		
TAA4DI28K415S	4 15/16 in.	22228	158.8	311.2	180.0	393.7	458.7	63.5	520.7	120.4	50.8	M24	134.6	77.5	79.3	10.5	131.0	131.0	72
TAA4DI28K500S	5 in.		6.25	12.25	7.09	15.50	18.06	2.50	20.50	4.74	2.00	7/8	5.30	3.05	3.12	0.41	5.16	5.16	159
TAA4DI28K125S	125 mm																		
TAA4DI32K140S	140 mm	23132 ⁽²⁾	181.1	352.6	210.0	482.6	524.0	76.2	601.7	165.1	63.5	M24	168.7	-	90.5	19.1	-	185.0	119
TAA4DI32K506S	5 3/16 in.		7.13	13.88	8.27	19.00	20.63	3.00	23.69	6.50	2.50	1	6.64		3.56	0.75		7.28	263
TAA4DI32K507S	5 7/16 in.																		
TAA4DI32K508S	5 1/2 in.	23134 ⁽²⁾	181.1	352.6	220.0	482.6	524.0	76.2	601.7	167.6	63.5	M24	169.6	-	94.7	15.0	-	186.7	120
TAA4DI34K150S	150 mm		7.13	13.88	8.66	19.00	20.63	3.00	23.69	6.60	2.50	1	6.68		3.73	0.59		7.35	264
TAA4DI34K513S	5 13/16 in.																		
TAA4DI34K514S	5 7/8 in.																		
TAA4DI34K515S	5 15/16 in.																		
TAA4DI34K600S	6 in.																		

⁽¹⁾Double-nut (TAA) part number shown. Single-nut (TA) version available upon request.

⁽²⁾Insert size 23132K and above come standard with double nut tapered adapter

TAAPH SAF-STYLE FOUR-BOLT PILLOW BLOCKS

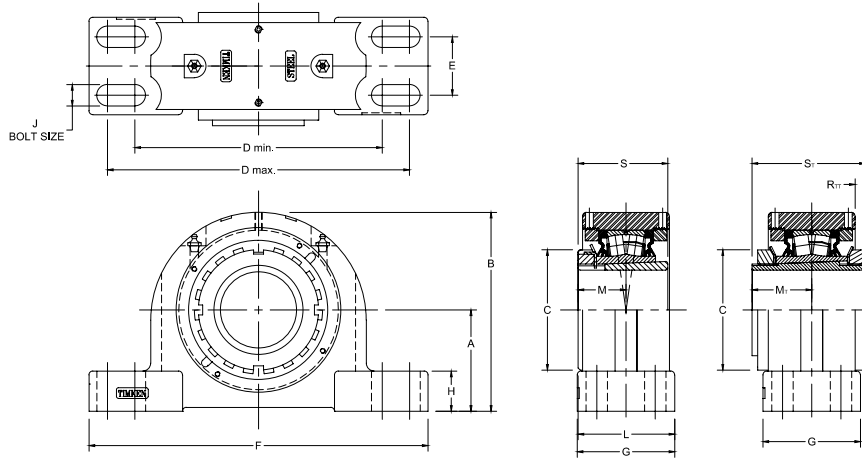

Bearing Part No. ⁽¹⁾	Shaft Dia.	Bearing No.	A	B	C	D min.	D max.	E	F	G	H	J	L	M	M _T	R _{TT}	S	S _T	Wt.
	mm in.		mm in.	mm in.	mm in.	mm in.	mm in.	mm in.	mm in.	mm in.	mm in.	mm in.	mm in.	mm in.	mm in.	mm in.	mm in.	mm in.	mm lbs.
TAAPH11K115S	1 15/16 in.	22211	69.9	134.9	74.9	182.4	217.4	39.9	251.0	68.6	31.8	16	69.9	35.6	39.1	7.1	58.9	76.33	8.6
TAAPH11K200S	2 in.		2.75	5.31	2.95	7.18	8.56	1.57	9.88	2.70	1.25	5/8	2.75	1.40	1.54	0.28	2.32	3.01	19
TAAPH11K050S	50 mm																		
TAAPH13K203S	2 3/16 in.	22213	76.2	151.1	85.1	182.4	217.4	50.8	261.9	82.6	31.2	12	81.0	39.6	43.7	5.1	65.0	82.83	11.3
TAAPH13K204S	2 1/4 in.		3.00	5.95	3.35	7.18	8.56	2.00	10.31	3.25	1.23	1/2	3.19	1.56	1.72	0.20	2.56	3.26	25
TAAPH13K060S	60 mm																		
TAAPH15K207S	2 7/16 in.	22215	82.6	162.1	98.0	201.7	246.1	47.8	276.4	79.5	32.8	12	83.6	43.9	48.7	8.3	72.9	92.33	13.2
TAAPH15K208S	2 1/2 in.		3.25	6.38	3.86	7.94	9.69	1.88	10.88	3.13	1.29	1/2	3.29	1.73	1.92	0.33	2.87	3.64	29
TAAPH15K065S	65 mm																		
TAAPH16K211S	2 11/16 in.	22216	88.9	176.6	104.7	228.6	279.4	53.9	330.2	88.9	31.7	16	91.7	47.5	51.7	11.3	77.7	99.33	14.5
TAAPH16K212S	2 3/4 in.		3.50	6.96	4.12	9.00	11.00	2.13	13.00	3.50	1.25	5/8	3.61	1.87	2.04	0.45	3.06	3.91	32
TAAPH16K070S	70 mm																		
TAAPH17K215S	2 15/16 in.	22217	95.3	182.9	110.0	239.8	287.3	53.9	320.8	92.2	32.0	16	96.0	49.8	50.2	16.0	82.0	104.33	16.8
TAAPH17K300S	3 in.		3.75	7.20	4.33	9.44	11.31	2.13	12.63	3.63	1.26	5/8	3.78	1.96	1.98	0.63	3.23	4.12	37
TAAPH17K075S	75 mm																		
TAAPH18K303S	3 3/16 in.	22218	101.6	202.1	119.6	254.0	298.5	54.0	349.3	98.4	41.3	16	101.2	52.0	56.6	12.3	86.0	108.83	19.1
TAAPH18K304S	3 1/4 in.		4.00	7.96	4.71	10.00	11.75	2.13	13.75	3.88	1.63	5/8	3.98	2.05	2.23	0.49	3.39	4.28	42
TAAPH18K080S	80 mm																		
TAAPH20K307S	3 7/16 in.	22220	114.3	216.9	130.0	276.4	339.9	60.5	381	109.5	41.9	20	113.3	58.4	63.6	10.6	97.0	121.83	31.8
TAAPH20K308S	3 1/2 in.		4.50	8.54	5.12	10.88	13.38	2.38	15.00	4.31	1.65	3/4	4.46	2.30	2.51	0.42	3.82	4.80	70
TAAPH20K090S	90 mm																		
TAAPH22K315S	3 15/16 in.	22222	125.5	238.3	145.0	301.8	368.3	69.9	406.4	120.7	45.0	20	123.4	63.0	65.8	14.1	104.9	130.7	39.5
TAAPH22K400S	4 in.		4.94	9.38	5.71	11.88	14.50	2.75	16.00	4.75	1.77	3/4	4.86	2.48	2.59	0.56	4.13	5.15	87
TAAPH22K100S	100 mm																		
TAAPH24K403S	4 3/16 in.	22224	133.4	256.7	154.5	330.2	368.3	69.9	419.1	120.7	50.8	20	127.3	67.0	71.6	18.7	112.0	139.15	49.9
TAAPH24K404S	4 1/4 in.		5.25	10.11	6.08	13.00	14.50	2.75	16.50	4.75	2.00	3/4	5.01	2.64	2.82	0.73	4.41	5.48	110
TAAPH24K110S	110 mm																		
TAAPH26K407S	4 7/16 in.	22226	152.4	284.0	165.1	362.0	406.4	82.6	450.85	128.0	51.8	22	135.9	71.9	76.6	20.4	120.9	149.65	61.7
TAAPH26K408S	4 1/2 in.		6.00	11.18	6.50	14.25	16.00	3.25	17.75	5.04	2.04	7/8	5.35	2.83	3.01	0.80	4.76	5.89	136
TAAPH26K115S	115 mm																		
TAAPH28K415S	4 15/16 in.	22228	152.4	290.8	180.1	406.4	435.1	85.9	500.4	128.0	51.8	24	141.5	77.5	85.2	18.3	131.1	161.15	61.8
TAAPH28K500S	5 in.		6.00	11.45	7.09	16.00	17.13	3.38	19.70	5.04	2.04	1	5.57	3.05	3.35	0.72	5.16	6.34	136
TAAPH28K125S	125 mm																		

⁽¹⁾Double-nut (TAA/DAA) part number shown. Single-nut (TA/DV) version available upon request.

TAAPH SAF 500-STYLE FOUR-BOLT PILLOW BLOCKS

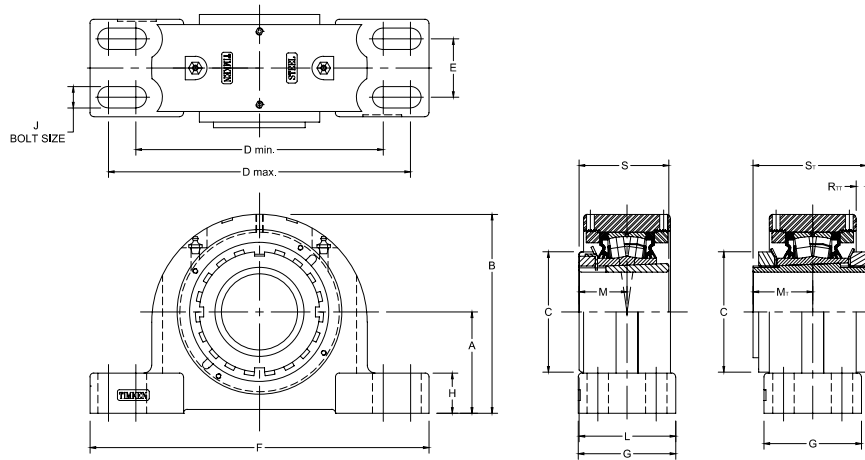

Bearing Part No. ⁽¹⁾	Shaft Dia.	Bearing No.	A	B	C	D min.	D max.	E	F	G	H	J	L	M _T	R _{T1}	S _T	Wt.
			mm in.	mm in.	mm in.	mm in.	mm in.	mm in.	mm in.	mm in.	mm in.	mm in.	mm in.	mm in.	mm in.	mm in.	mm in.
TAAPH30K503S0	5 3/16 in.	23130	160.3	320.6	200.0	431.8	463.6	95.2	539.8	171.5	66.2	M24	170	84	8	175	95.2
TAAPH30K504S0	5 1/4 in.		6.31	12.62	7.89	17.00	18.25	3.75	21.25	6.75	2.61	1	6.69	3.32	0.32	6.89	210
TAAPH30K135S0	135 mm																
TAAPH32K140S0	140 mm	23132															
TAAPH32K506S0	5 3/8 in.		169.9	330.2	210.0	441.3	489.0	95.2	558.8	171.5	76.2	M24	176	91	12	185	122.4
TAAPH32K507S0	5 7/16 in.		6.69	13.00	8.27	17.38	19.25	3.75	22.00	6.75	3.00	1	6.94	3.56	0.47	7.28	270
TAAPH32K508S0	5 1/2 in.																
TAAPH34K150S0	150 mm	23134															
TAAPH34K513S0	5 13/16 in.		179.4	339.8	220.0	493.6	549.4	108.0	628.7	171.5	85.9	M24	180	95	13	188	132.9
TAAPH34K514S0	5 7/8 in.		7.06	13.38	8.66	19.38	21.63	4.25	24.75	6.75	3.38	1	7.10	3.73	0.52	7.38	293
TAAPH34K515S0	5 15/16 in.																
TAAPH34K600S0	6 in.																
TAAPH36K160S0	160 mm	23136															
TAAPH36K605S0	6 3/16 in.		190.5	391.2	230.0	531.8	600.2	117.5	679.5	190.5	76.2	M24	196	99	14	197	159.2
TAAPH36K606S0	6 3/8 in.		7.50	15.40	9.06	20.88	23.63	4.63	26.75	7.5	3.00	1	7.72	3.90	0.57	7.74	351
TAAPH36K607S0	6 7/16 in.																
TAAPH36K608S0	6 1/2 in.																
TAAPH38K170S0	170 mm	23138															
TAAPH38K613S0	6 13/16 in.		200.0	400.1	240.0	550.9	619.3	114.3	711.2	190.5	85.9	M30	206.7	105	13.2	208	185.9
TAAPH38K614S0	6 7/8 in.		7.88	15.75	9.45	21.63	24.38	4.50	28.00	7.50	3.38	1 1/4	8.14	4.13	0.52	8.17	410
TAAPH38K615S0	6 15/16 in.																
TAAPH38K700S0	7 in.																
TAAPH40K180S0	180 mm	23140															
TAAPH40K702S0	7 1/8 in.		209.6	429.3	250.0	573.1	635.0	127.0	749.3	210.0	80.0	M30	215	110	16	218	207.7
TAAPH40K703S0	7 3/16 in.		8.25	16.16	9.84	22.50	25.00	5.00	29.50	8.27	3.15	1 1/4	8.46	4.32	0.65	8.57	458
TAAPH40K704S0	7 1/4 in.																
TAAPH44K200S0	200 mm	23144															
TAAPH44K713S0	7 13/16 in.		241.3	455.3	280.0	630.4	708.2	133.4	831.9	225.0	85.1	M36	231	119	21	235	284.4
TAAPH44K714S0	7 7/8 in.		9.50	17.93	11.02	24.75	27.88	5.25	32.75	8.86	3.35	1 1/2	9.11	4.68	0.81	9.24	627
TAAPH44K715S0	7 15/16 in.																
TAAPH44K800S0	8 in.																

⁽¹⁾Insert size 23132K and above come standard with double nut tapered adapter

TAAPHD SDAF 500-STYLE FOUR-BOLT PILLOW BLOCKS

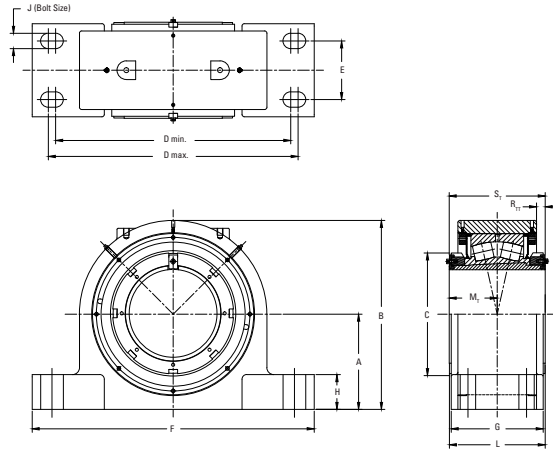

Bearing Part No. ⁽¹⁾	Shaft Dia.	Bearing No.	A	B	C	D min.	D max.	E	F	G	H	J	L	M _T	R _T	S _T	Wt.
	mm in.		mm in.	mm in.	mm in.	mm in.	mm in.	mm in.	mm in.	mm in.	mm in.	mm in.	mm in.	mm in.	mm in.	mm in.	kg lbs.
TAAPH34DK150S0	150 mm	23134	179.3 7.06	370.0 14.60	199.9 7.87	492.3 19.38	549.4 21.63	139.7 5.50	628.7 24.75	215.9 8.50	65.0 2.56	M30 1 ¼	203 7.98	95 3.73	13 0.52	188 7.38	132.9 293
TAAPH34DK513S0	5 13/16 in.																
TAAPH34DK514S0	5 7/8 in.																
TAAPH34DK515S0	5 15/16 in.																
TAAPH34DK600S0	6 in.																
TAAPH36DK160S0	160 mm	23136	190.5 7.50	391.2 15.40	210.1 8.27	530.4 20.88	600.2 23.63	149.4 5.88	679.5 26.75	219.5 8.64	69.9 2.75	M30 1 ¼	209 8.22	99 3.90	14 0.57	197 7.74	158.3 349
TAAPH36DK605S0	6 5/16 in.																
TAAPH36DK606S0	6 3/8 in.																
TAAPH36DK607S0	6 7/16 in.																
TAAPH36DK608S0	6 1/2 in.																
TAAPH38DK170S0	170 mm	23138	200.1 7.88	410.8 16.17	219.9 8.66	546.1 21.50	596.9 23.50	158.8 6.25	701.8 27.63	235.0 9.25	74.9 2.95	M30 1 3/8	199 7.83	104 4.08	13 0.52	208 8.17	186.8 412
TAAPH38DK613S0	6 13/16 in.																
TAAPH38DK614S0	6 7/8 in.																
TAAPH38DK615S0	6 15/16 in.																
TAAPH38DK700S0	7 in.																
TAAPH40DK180S0	180 mm	23140	209.5 8.25	429.2 16.90	240.0 9.45	584.2 23.00	635.0 25.00	171.5 6.75	730.3 28.75	247.7 9.75	80.0 3.15	M30 1 3/8	234 9.21	110 4.32	16 0.65	218 8.57	220.4 486
TAAPH40DK702S0	7 1/8 in.																
TAAPH40DK703S0	7 3/16 in.																
TAAPH40DK704S0	7 1/4 in.																
TAAPH44DK200S0	200 mm																
TAAPH44DK713S0	7 13/16 in.																
TAAPH44DK714S0	7 7/8 in.																
TAAPH44DK715S0	7 15/16 in.																
TAAPH44DK800S0	8 in.																

TAAPH6 SAF 600-STYLE FOUR-BOLT PILLOW BLOCKS

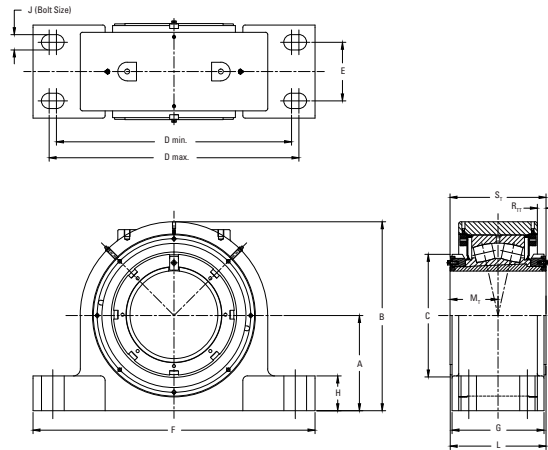

Bearing Part No. ⁽¹⁾	Shaft Dia.	Bearing No.	A	B	C	D min.	D max.	E	F	G	H	J	L	M _T	R _T	S _T	Wt.
	mm in.		mm in.	mm in.	mm in.	mm in.	mm in.	mm in.	mm in.	mm in.	mm in.	mm in.	mm in.	mm in.	mm in.	mm in.	kg lbs.
TAAPH634K513S0	150 mm	23134	209.6 8.25	400.4 15.76	220.0 8.66	571.5 22.50	635.0 25.00	127.0 5.00	749.3 29.50	203.2 8.00	65.0 2.56	M30 1 ¼	196 7.73	95 3.73	13 0.53	187.5 7.38	161.1 355
TAAPH634K514S0	5 13/16 in.																
TAAPH634K515S0	5 7/8 in.																
TAAPH634K600S0	5 15/16 in.																
TAAPH634K150S0	6 in.																
TAAPH636K605S0	160 mm	23136	225.4 8.88	426.7 16.80	230.0 9.06	609.6 24.00	676.3 26.63	133.4 5.25	793.8 31.25	250.8 9.88	69.9 2.75	M30 1 ¼	224 8.84	99 3.90	14 0.57	197 7.74	193.6 427
TAAPH636K606S0	6 5/16 in.																
TAAPH636K607S0	6 3/8 in.																
TAAPH636K608S0	6 7/16 in.																
TAAPH636K160S0	6 1/2 in.																
TAAPH638K613S0	170 mm	23138	241.3 9.50	452.1 17.80	240.0 9.45	268.7 24.75	708.0 27.88	133.4 5.25	831.9 32.75	209.6 8.25	74.9 2.95	M36 1 ½	210 8.26	105 4.13	15 0.60	208 8.17	229.1 505
TAAPH638K614S0	6 13/16 in.																
TAAPH638K615S0	6 7/8 in.																
TAAPH638K700S0	6 15/16 in.																
TAAPH638K170S0	7 in.																
TAAPH640K702S0	180 mm	23140	250.8 9.88	472.4 18.6	250.0 9.84	666.8 26.25	749.3 29.50	139.7 5.50	870.0 34.3	215.9 8.50	80.0 3.15	M36 1 ½	217.9 8.58	110 4.32	16 0.65	218 8.57	272.4 601
TAAPH640K703S0	7 1/8 in.																
TAAPH640K704S0	7 3/16 in.																
TAAPH640K180S0	7 1/4 in.																

TAAPH6D SDAF 600-STYLE FOUR-BOLT PILLOW BLOCKS

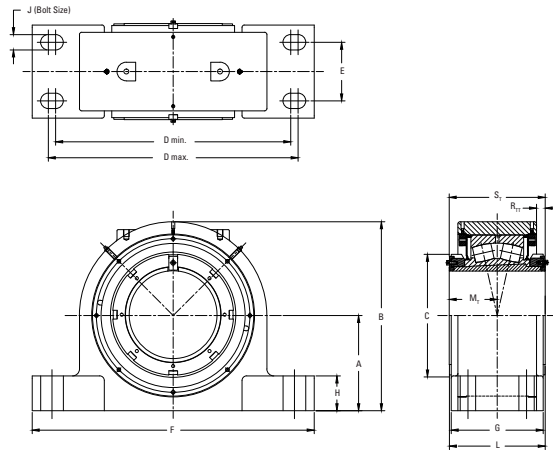

Bearing Part No. ⁽¹⁾	Shaft Dia.	Bearing No.	A	B	C	D min.	D max.	E	F	G	H	J	L	M _T	R _T	S _T	Wt.
			mm in.	mm in.	mm in.	mm in.	mm in.	mm in.	mm in.	mm in.	mm in.	mm in.	mm in.	mm in.	mm in.	mm in.	mm in.
TAAPH634DK150SO	150 mm	23134	209.6 8.25	400.4 15.76	220.0 8.66	584.2 23.00	635.0 25.00	171.5 6.75	730.3 28.75	247.7 9.75	65.0 2.56	M30 1 3/8	219 8.60	95 3.73	13 0.53	187.5 7.38	158.4 349
TAAPH634DK513SO	5 13/16 in.																
TAAPH634DK514SO	5 7/8 in.																
TAAPH634DK515SO	5 15/16 in.																
TAAPH634DK600SO	6 in.																
TAAPH636DK160SO	160 mm	23136	225.4 8.88	426.7 16.80	230.0 9.06	612.8 24.13	669.9 26.38	174.6 6.88	774.7 30.50	250.8 9.88	69.9 2.75	M36 1 1/2	224 8.84	99 3.90	14 0.57	197 7.74	189.6 418
TAAPH636DK605SO	6 5/16 in.																
TAAPH636DK606SO	6 3/8 in.																
TAAPH636DK607SO	6 7/16 in.																
TAAPH636DK608SO	6 1/2 in.																
TAAPH638DK170SO	170 mm	23138	241.3 9.50	452.1 17.80	240.0 9.45	650.9 25.63	708.0 27.88	184.2 7.25	812.8 32.00	260.4 10.25	74.9 2.95	M36 1 1/2	235 9.26	105 4.13	15 0.60	208 8.17	226.4 500
TAAPH638DK613SO	6 13/16 in.																
TAAPH638DK614SO	6 7/8 in.																
TAAPH638DK615SO	6 15/16 in.																
TAAPH638DK700SO	7 in.																
TAAPH640DK180SO	180 mm	23140	250.8 9.88	472.4 18.6	250.0 9.84	676.3 26.63	743.0 29.25	193.7 7.63	850.9 33.5	269.9 10.63	80.0 3.15	M36 1 3/8	244.9 9.64	110 4.32	16 0.65	218 8.57	268.3 592
TAAPH640DK702SO	7 1/8 in.																
TAAPH640DK703SO	7 3/8 in.																
TAAPH640DK704SO	7 1/4 in.																

TAAPH0 SAF 230-STYLE FOUR-BOLT PILLOW BLOCKS

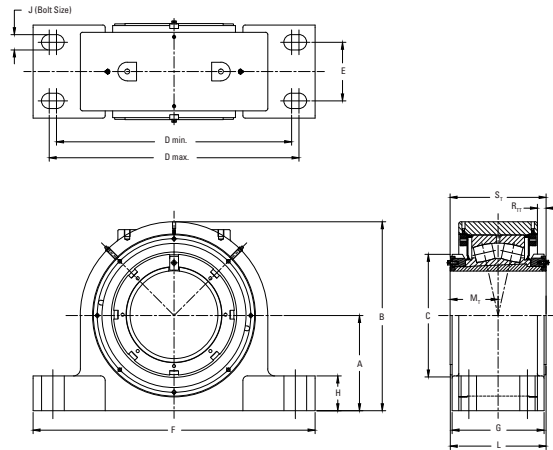

Bearing Part No.	Shaft Dia.	Bearing No.	A	B	C	D min.	D max.	E	F	G	H	J	L	M _T	R _{TT}	S _T	Wt.
			mm in.	mm in.	mm in.	mm in.	mm in.	mm in.	mm in.	mm in.	mm in.	mm in.	mm in.	mm in.	mm in.	mm in.	mm in.
TAAPH034K150S0	150 mm	23134	152.4 6.00	330.2 13.00	220 8.66	406.4 16.00	435.1 17.13	85.7 3.38	511.3 20.13	171.5 6.75	65.0 2.56	M24 1	184.8 7.28	99 3.90	9.10 0.36	188 7.38	106 234
TAAPH034K513S0	5 13/16 in.																
TAAPH034K514S0	5 7/8 in.																
TAAPH034K515S0	5 9/16 in.																
TAAPH034K600S0	6 in.																
TAAPH036K160S0	160 mm	23136	169.9 6.69	342.9 13.5	230 9.06	441.4 17.38	488.9 19.25	95.3 3.75	558.8 22.00	180.1 7.09	59.9 2.36	M24 1	189.1 7.45	99 3.90	14.0 0.57	197 7.74	131 289
TAAPH036K605S0	6 3/16 in.																
TAAPH036K606S0	6 3/8 in.																
TAAPH036K607S0	6 7/16 in.																
TAAPH036K608S0	6 1/2 in.																
TAAPH038K170S0	170 mm	23138	169.9 6.69	355.6 14.00	240 9.45	441.5 17.38	488.9 19.25	95.2 3.75	558.8 22.00	196.2 7.72	54.9 2.16	M24 1	203.0 7.99	105 4.13	15.3 0.60	208 8.17	145 319
TAAPH038K613S0	6 13/16 in.																
TAAPH038K614S0	6 7/8 in.																
TAAPH038K615S0	6 9/16 in.																
TAAPH034K700S0	7 in.																
TAAPH040K180S0	180 mm	23140	179.3 7.06	380.5 14.98	250 9.84	492.3 19.38	549.4 21.63	107.0 4.25	628.6 24.75	206.2 8.12	49.3 1.94	M24 1	213.1 8.39	110 4.32	16.4 0.65	218 8.57	182 401
TAAPH040K702S0	7 1/8 in.																
TAAPH040K703S0	7 3/16 in.																
TAAPH040K704S0	7 1/4 in.																
TAAPH044K200S0	200 mm																
TAAPH044K713S0	7 13/16 in.																
TAAPH044K714S0	7 7/8 in.																
TAAPH044K715S0	7 15/16 in.																
TAAPH044K800S0	8 in.																
TAAPH048K220S0	220 mm	23148	209.5 8.25	459.7 18.10	300 11.81	571.5 22.50	635.0 25.00	127.0 5.00	749.3 29.50	203.2 8.00	89.9 3.54	M30 1 1/4	226.6 8.92	125 4.93	22.4 0.88	247 9.71	270 595
TAAPH048K807S0	8 7/16 in.																
TAAPH048K808S0	8 1/2 in.																
TAAPH048K815S0	8 9/16 in.																
TAAPH048K900S0	9 in.																
TAAPH052K240S0	240 mm	23152	241.3 9.5	512.1 20.16	330 12.99	628.6 24.75	708.1 27.88	133.3 5.25	831.8 32.75	236.2 9.30	76.2 3.00	M36 1 1/2	256.5 10.10	138.4 5.45	29.1 1.15	275 10.82	346 764
TAAPH052K907S0	9 7/16 in.																
TAAPH052K908S0	9 1/2 in.																

TAAPH0 SDAF 230-STYLE FOUR-BOLT PILLOW BLOCKS

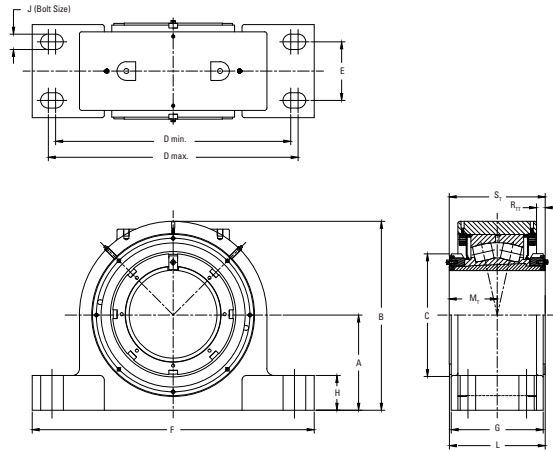

Bearing Part No. ⁽¹⁾	Shaft Dia.	Bearing No.	A	B	C	D min.	D max.	E	F	G	H	J	L	M _T	R _T	S _T	Wt.
	mm in.		mm in.	mm in.	mm in.	mm in.	mm in.	mm in.	mm in.	mm in.	mm in.	mm in.	mm in.	mm in.	mm in.	mm in.	kg lbs.
TAAPH056K260S0	260 mm	23156	250.9 9.88	522.0 20.55	350 13.78	666.7 26.25	749.3 29.50	139.7 5.50	869.0 34.25	236.2 9.30	71.1 2.80	M36 1 ½	256.8 10.11	139 5.46	20.2 0.80	275 10.83	421 928
TAAPH056K915S0	9 15/16 in.																
TAAPH056K1000S0	10 in.																
TAAPH056K1007S0	10 7/16 in.																
TAAPH056K1008S0	10 1/2 in.	23160	304.8 12.00	595.9 23.46	380 14.96	831.8 32.75	850.9 33.50	228.6 9.00	971.6 38.25	304.8 12.00	104.9 4.13	M42 1 5/8	297.9 11.73	146 5.73	146 5.73	287 11.29	569 1255
TAAPH060K280S0	280 mm																
TAAPH060K1015S0	10 15/16 in.																
TAAPH060K1100S0	11 in.																
TAAPH064K300S0	300 mm	23164	304.8 12.00	616.0 24.25	400 15.75	831.9 32.75	850.9 33.50	228.6 9.00	971.6 38.25	342.9 13.50	89.4 3.52	M42 1 5/8	327.1 12.88	156 6.13	19.8 0.78	307 12.07	618 1362
TAAPH064K1107S0	11 7/16 in.																
TAAPH064K1108S0	11 1/2 in.																
TAAPH064K1115S0	11 15/16 in.																
TAAPH064K1200S0	12 in.	23168	304.8 12.00	645.6 25.42	440 17.32	812.8 32.00	850.9 33.50	254.0 10.00	990.6 39.00	349.3 13.75	64.3 2.53	M48 1 7/8	350.4 13.80	176 6.92	32.7 1.29	347 13.65	709 1564
TAAPH068K320S0	320 mm																
TAAPH068K1207S0	12 7/16 in.																
TAAPH068K1208S0	12 1/2 in.																
TAAPH072K340S0	340 mm	23172	325.3 12.81	670.6 26.39	460 18.11	889.0 35.00	927.1 36.50	266.7 10.50	1060.4 41.75	368.3 14.50	72.1 2.84	M48 1 7/8	357.5 14.08	180 7.08	35.8 1.41	355 13.96	802 1770
TAAPH072K1215S0	12 15/16 in.																
TAAPH072K1300S0	13 in.																
TAAPH072K1307S0	13 7/16 in.																
TAAPH072K1308S0	13 1/2 in.	23176	325.3 12.81	680.5 26.79	490 19.29	889.0 35.00	927.1 36.50	266.7 10.50	1060.4 41.75	342.9 13.50	115.0 4.53	M48 1 7/8	354.5 13.96	183 7.21	37.4 1.47	361 14.20	845 1863
TAAPH076K360S0	360 mm																
TAAPH076K1315S0	13 15/16 in.																
TAAPH076K1400S0	14 in.																
TAAPH080K380S0	380 mm	23180	368.3 14.50	763.3 30.05	520 20.47	996.9 39.25	1035.0 40.75	279.4 11.00	1168.4 46.00	406.4 16.00	94.5 3.72	M50 2	381.7 15.03	188 7.40	39.4 1.55	371 14.59	1126 2482
TAAPH080K1415S0	14 15/16 in.																
TAAPH080K1500S0	15 in.																

⁽¹⁾Insert size 23132K and above come standard with double nut tapered adapter

TAAPH1 SDAF 231-STYLE FOUR-BOLT PILLOW BLOCKS

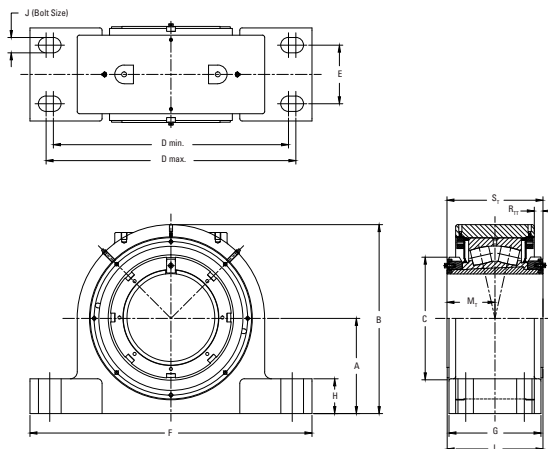

Bearing Part No. ⁽¹⁾	Shaft Dia.	Bearing No.	A	B	C	D min.	D max.	E	F	G	H	J	L	M _T	R _{TT}	S _T	Wt.																
			mm in.	mm in.	mm in.	mm in.	mm in.	mm in.	mm in.	mm in.	mm in.	mm in.	mm in.	mm in.	mm in.	mm in.	mm in.	mm in.	kg lbs.														
TAAPH152K240S0	240 mm	23152	260.3	531	330	736.6	774.7	222.2	889.0	298.5	95.0	M42	288	138	29	275	379																
TAAPH152K907S0	9 7/16 in.		10.25	20.91	12.99	29.00	30.50	8.75	35.00	11.75	3.74	1 3/4	11.33	5.45	1.15	10.82	836																
TAAPH152K908S0	9 1/2 in.																																
TAAPH156K260S0	260 mm	23156	304.8	576	350	762	851	228.6	971.5	330.2	101.6	M42	304	139	20	275	512																
TAAPH156K915S0	9 15/16 in.																	12.00	22.67	13.78	30.00	33.50	9.00	38.25	13.00	4.00	1 3/4	11.96	5.46	0.88	10.83	1130	
TAAPH156K1000S0	10 in.																																
TAAPH156K1007S0	10 7/16 in.																																
TAAPH156K1008S0	10 1/2 in.																																
TAAPH160K280S0	280 mm	23160	304.8	596	380	831.8	850.9	228.6	971.6	305.0	104.9	M42	298	146	18	287	569																
TAAPH160K1015S0	10 15/16 in.																	12.00	23.46	14.96	32.75	33.50	9.00	38.25	12.00	4.33	1 3/4	11.73	5.73	0.71	11.29	1255	
TAAPH160K1100S0	11 in.																																
TAAPH164K300S0	300 mm	23164	325.4	636	400	889.0	927.1	266.7	1060.5	342.9	109.9	M42	327	156	20	307	676																
TAAPH164K1107S0	11 7/16 in.																	12.81	25.06	15.75	35.00	36.50	10.50	41.75	13.50	4.33	1 3/4	12.88	6.13	0.78	12.07	1490	
TAAPH164K1108S0	11 1/2 in.																																
TAAPH164K1115S0	11 15/16 in.																																
TAAPH164K1200S0	12 in.																																
TAAPH168K320S0	320 mm	23168	355.6	696	440	933.5	971.6	273.1	1111.3	349	115.0	M50	350	176	33	347	841																
TAAPH168K1207S0	12 7/16 in.																	14.00	27.42	17.32	36.75	38.25	10.75	43.75	13.75	4.53	2	13.80	6.92	1.29	13.65	1855	
TAAPH168K1208S0	12 1/2 in.																																
TAAPH172K340S0	340 mm	23172	368.3	713	460	996.9	1035.0	279.4	1168.4	368.3	115.0	M50	358	180	36	355	920																
TAAPH172K1215S0	12 15/16 in.																	14.50	28.08	18.11	39.25	40.75	11.00	46.00	14.5	4.53	2	14.08	7.08	1.41	13.96	2029	
TAAPH172K1300S0	13 in.																																
TAAPH172K1307S0	13 7/16 in.																																
TAAPH172K1308S0	13 1/2 in.																																
TAAPH176K360S0	360 mm	23176	368.3	729	490	996.9	1035.0	279.4	1168.4	368.3	115.0	M50	361	183	37	361	965																
TAAPH176K1315S0	13 15/16 in.																	14.50	28.71	19.29	39.25	40.75	11.00	46.00	14.5	4.53	2	14.2	7.21	1.5	14.20	2128	
TAAPH176K1400S0	14 in.																																
TAAPH180K380S0	380 mm	23180	393.7	789	520	1060.4	1104.9	311.1	1238.2	406.4	119.9	M60	382	188	39	371	1205																
TAAPH180K1415S0	14 15/16 in.																	15.50	31.0	20.47	41.75	43.50	12.25	48.75	16.00	4.72	2 1/4	15.0	7.40	1.6	14.59	2657	
TAAPH180K1500S0	15 in.																																

⁽¹⁾Insert size 23132K and above come standard with double nut tapered adapter

TAAPG SN-STYLE FOUR-BOLT PILLOW BLOCKS

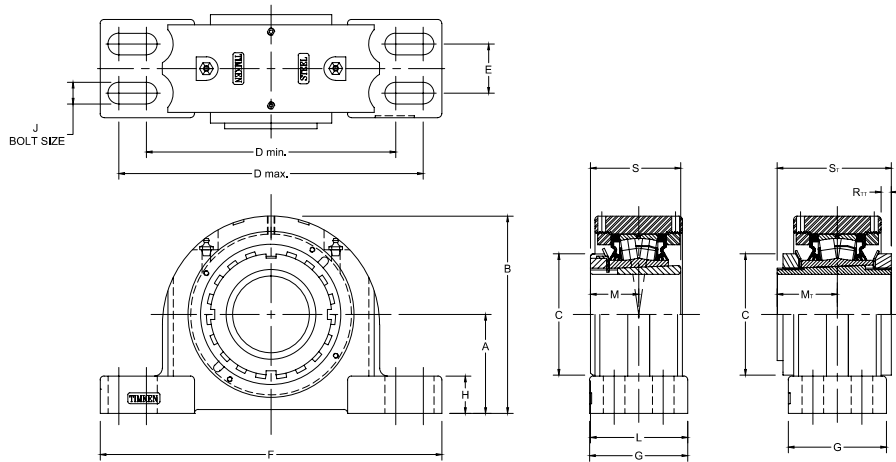

Bearing Part No. ⁽¹⁾	Shaft Dia.	Bearing No.	A	B	C	D min.	D max.	E	F	G	H	J	L	M	M _T	R _{T1}	S	S _T	Wt.
			mm in.	mm in.	mm in.	mm in.	mm in.	mm in.	mm in.	mm in.	mm in.	mm in.	mm in.	mm in.	mm in.	mm in.	mm in.	mm in.	mm in.
TAAPG11K115S	1 1/16 in.	22211	69.9	134.9	74.9	182.4	217.4	39.9	251.0	68.6	31.8	16	69.9	35.6	39.1	7.1	58.9	76.33	8.6
TAAPG11K200S	2 in.		2.75	5.31	2.95	7.18	8.56	1.57	9.88	2.70	1.25	5/8	2.75	1.40	1.54	0.28	2.32	3.01	19
TAAPG11K050S	50 mm																		
TAAPG12K055S	55 mm	22212	70.0	140.5	79.8	177.8	219.2	35.1	254.0	69.9	31.8	16	72.6	37.6	41.1	7.0	62.0	78.33	9.9
TAAPG12K055S	55 mm		2.756	5.53	3.14	7.00	8.63	1.38	10.00	2.75	1.25	5/8	2.86	1.48	1.62	0.28	2.44	3.08	22
TAAPG13K203S	2 3/16 in.	22213	80.0	154.9	85.1	182.4	217.4	48.0	261.9	82.6	35.1	16	81.0	39.6	43.7	5.1	65.0	82.83	11.3
TAAPG13K204S	2 1/4 in.		3.15	6.10	3.35	7.18	8.56	1.89	10.31	3.25	1.38	5/8	3.19	1.56	1.72	0.20	2.56	3.26	25
TAAPG13K060S	60 mm																		
TAAPG15K207S	2 7/16 in.	22215	80.0	162.1	98.0	201.7	246.1	39.6	276.4	79.5	30.2	16	83.8	43.9	48.7	8.3	72.9	92.33	13.2
TAAPG15K208S	2 1/2 in.		3.15	6.38	3.86	7.94	9.69	1.56	10.88	3.13	1.19	5/8	3.30	1.73	1.92	0.33	2.87	3.64	29
TAAPG15K065S	65 mm																		
TAAPG16K211S	2 11/16 in.	22216	95.0	180.3	104.6	235.0	266.7	50.0	315.0	89.9	31.8	16	92.5	47.5	51.7	11.3	78.0	99.33	14.9
TAAPG16K212S	2 3/4 in.		3.74	7.10	4.12	9.25	10.50	1.97	12.40	3.54	1.25	5/8	3.64	1.87	2.04	0.45	3.07	3.91	33
TAAPG16K070S	70 mm																		
TAAPG17K215S	2 15/16 in.	22217	95.0	182.9	110.0	239.8	287.3	52.3	320.8	92.2	31.8	20	96.0	49.8	50.2	16.0	82.0	104.33	16.8
TAAPG17K300S	3 in.		3.74	7.20	4.33	9.44	11.31	2.06	12.63	3.63	1.25	3/4	3.78	1.96	1.98	0.63	3.23	4.12	37
TAAPG17K075S	75 mm																		
TAAPG18K080S	80 mm	22218	100.0	195.3	119.6	282.7	298.5	50.0	344.9	100.1	39.6	16	102.1	52.1	56.6	12.3	86.1	108.83	24.5
TAAPG18K303S	3 3/16 in.		3.937	7.69	4.71	11.13	11.75	1.97	13.58	3.94	1.56	5/8	4.02	2.05	2.23	0.49	3.39	4.28	54
TAAPG18K304S	3 1/4 in.																		
TAAPG19K085S	85 mm	22219	112.0	212.3	124.7	282.7	298.5	50.0	344.9	100.1	39.6	16	104.6	54.6	59.2	13.2	89.9	113.83	25.4
TAAPG19K085S	85 mm		4.409	8.36	4.91	11.13	11.75	1.97	13.58	3.94	1.56	5/8	4.12	2.15	2.33	0.52	3.54	4.48	56
TAAPG20K307S	3 7/16 in.	22220	112.0	214.6	130.0	276.4	339.9	60.5	381.0	109.5	39.6	20	113.3	58.4	63.6	10.6	97.0	121.83	31.8
TAAPG20K308S	3 1/2 in.		4.409	8.45	5.12	10.88	13.38	2.38	15.00	4.31	1.56	3/4	4.46	2.30	2.51	0.42	3.82	4.80	70
TAAPG20K090S	90 mm																		
TAAPG22K315S	3 15/16 in.	22222	125.0	238.3	145.0	301.8	368.3	69.9	406.4	120.7	44.5	20	123.4	63.0	65.8	14.1	104.9	130.7	39.5
TAAPG22K400S	4 in.		4.921	9.38	5.71	11.88	14.50	2.75	16.00	4.75	1.75	3/4	4.86	2.48	2.59	0.56	4.13	5.15	87
TAAPG22K100S	100 mm																		
TAAPG24K403S	4 3/16 in.	22224	140.0	262.9	154.4	330.2	355.6	70.1	410.0	120.7	50.8	16	127.5	67.1	71.6	16.8	112.0	139.15	49.9
TAAPG24K404S	4 1/4 in.		5.512	10.35	6.08	13.00	14.00	2.76	16.14	4.75	2.00	5/8	5.02	2.64	2.82	0.66	4.41	5.48	110
TAAPG24K110S	110 mm																		
TAAPG26K407S	4 7/16 in.	22226	150.0	281.7	165.1	367.28	400.1	81.0	444.5	128.0	49.3	24	135.9	71.88	76.6	20.4	120.9	149.65	61.7
TAAPG26K408S	4 1/2 in.		5.906	11.09	6.50	14.46	15.75	3.19	17.50	5.04	1.94	1	5.35	2.83	3.01	0.80	4.76	5.89	136
TAAPG26K115S	115 mm																		
TAAPG28K415S	4 15/16 in.	22228	150.0	288.4	180.1	384.3	447.8	80.0	500.4	128.0	49.3	24	141.5	77.5	85.2	18.3	131.1	161.15	61.8
TAAPG28K500S	5 in.		5.906	11.36	7.09	15.13	17.63	3.15	19.70	5.04	1.94	1	5.57	3.05	3.35	0.72	5.16	6.34	136
TAAPG28K125S	125 mm																		

⁽¹⁾Double-nut (TAA/DAA) part number shown. Single-nut (TA/DV) version available upon request.

TAASN 3000 SERIES FOUR-BOLT PILLOW BLOCK

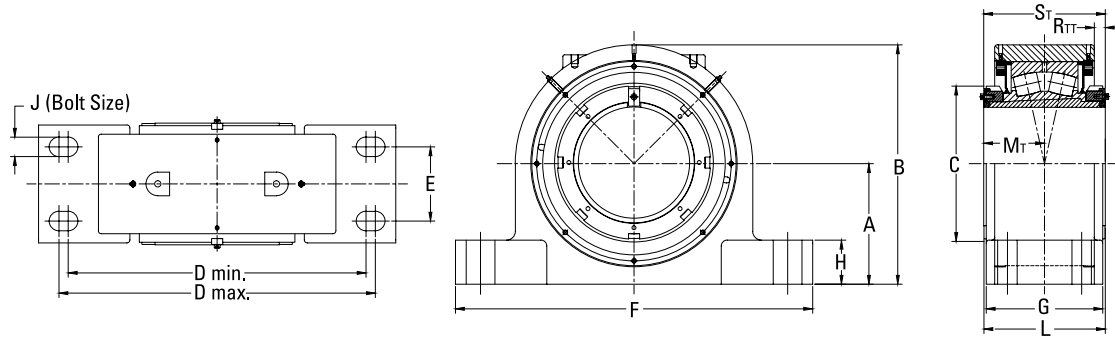

Bearing Part No. ⁽¹⁾	Shaft Dia.	Bearing No.	A	B	C	D min.	D max.	E	F	G	H	J	L	M _T	N	R _T	S _T	Wt.
			mm in.	mm in.	mm in.	mm in.	mm in.	mm in.	mm in.	mm in.	mm in.	mm in.	mm in.	mm in.	mm in.	mm in.	mm in.	mm in.
TAA30SN36K160S0	160 mm	23136	170 6.69	343 13.50	210 8.27	410 16.14	450 17.72	100 3.94	510 20.08	180 7.09	60 2.36	24 1	189 7.44	99 3.90	48 1.89	14 0.56	197 7.74	112 248
TAA30SN36K605S0	6 3/8 in.																	
TAA30SN36K606S0	6 3/8 in.																	
TAA30SN36K607S0	6 7/8 in.																	
TAA30SN36K608S0	6 1/2 in.																	
TAA30SN38K170S0	170 mm	23138	180 7.09	365 14.37	220 8.66	430 16.93	470 18.50	110 4.33	530 20.87	196 7.72	65 2.56	24 1	203 8.21	105 4.13	48 1.89	15 0.60	208 8.17	131 289
TAA30SN38K613S0	6 13/16 in.																	
TAA30SN38K614S0	6 7/8 in.																	
TAA30SN38K615S0	6 13/16 in.																	
TAA30SN38K700S0	7 in.																	
TAA30SN40K180S0	180 mm	23140	190 7.48	391 15.39	240 9.45	460 18.11	500 19.69	120 4.72	560 22.05	206 8.13	60 2.36	24 1	213 8.38	110 4.32	48 1.89	17 0.66	218 8.57	153 339
TAA30SN40K702S0	7 1/8 in.																	
TAA30SN40K703S0	7 3/8 in.																	
TAA30SN40K704S0	7 1/4 in.																	
TAA30SN44K200S0	200 mm																	
TAA30SN44K713S0	7 13/16 in.																	
TAA30SN44K714S0	7 7/8 in.																	
TAA30SN44K715S0	7 13/16 in.																	
TAA30SN44K800S0	8 in.																	
TAA30SN48K220S0	220 mm	23148	220 8.27	454 17.87	300 11.81	520 20.47	560 22.05	140 5.51	640 25.20	240 9.45	90 3.54	30 1 1/4	238 9.38	125 4.93	55 2.17	22 0.87	247 9.71	230 506
TAA30SN48K807S0	8 7/8 in.																	
TAA30SN48K808S0	8 1/2 in.																	
TAA30SN48K815S0	8 13/16 in.																	
TAA30SN48K900S0	9 in.																	
TAA30SN52K240S0	240 mm	23152	240 9.45	496 19.53	330 12.99	580 22.83	620 24.41	150 5.91	700 27.56	254 10	75 2.96	30 1 1/4	257 10.10	91 5.45	55 2.17	18 0.72	275 10.82	289 637
TAA30SN52K907S0	9 7/8 in.																	
TAA30SN52K908S0	9 1/2 in.																	

⁽¹⁾SN 3000 Series comes standard with double nut tapered adapter

Continued on next page.

TAASN 3000 SERIES FOUR-BOLT PILLOW BLOCK – continued

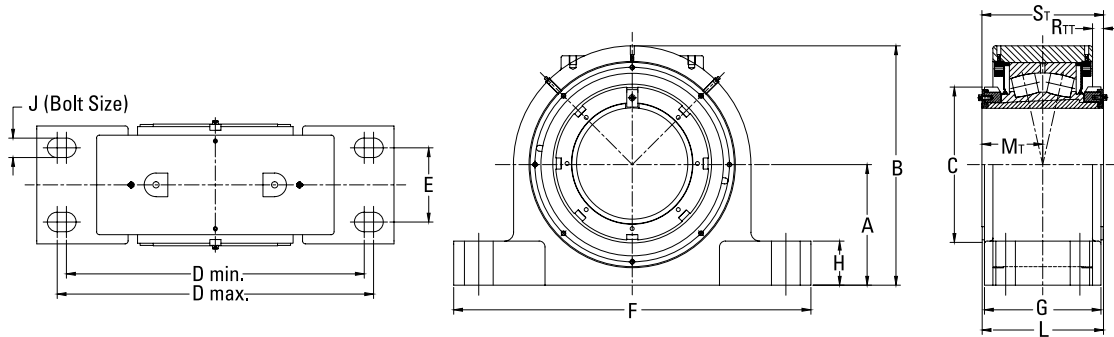

Continued from previous page.

Bearing Part No. ⁽¹⁾	Shaft Dia.	Bearing No.	A	B	C	D min.	D max.	E	F	G	H	J	L	M _T	N	R _T	S _T	Wt.	
	mm in.		mm in.	mm in.	mm in.	mm in.	mm in.	mm in.	mm in.	mm in.	mm in.	mm in.	mm in.	mm in.	mm in.	mm in.	mm in.	mm in.	kg lbs.
TAA30SN56K260SO	260 mm	23156	260 10.24	531 20.91	350 13.78	642 25.28	682 26.85	160 6.30	770 30.31	236 9.30	82 3.22	36 1 ½	257 10.11	139 5.46	62 2.44	20 0.80	275 10.83	358 790	
TAA30SN56K915SO	9 15/16 in.																		
TAA30SN56K1000SO	10 in.																		
TAA30SN56K1007SO	10 7/16 in.																		
TAA30SN56K1008SO	10 1/2 in.																		
TAA30SN60K280SO	280 mm	23160	280 11.02	571 22.48	380 14.96	650 25.59	690 27.17	160 6.30	790 31.10	266 10.48	105 4.13	36 1 ½	279 10.97	146 5.73	62 2.44	18 0.71	287 11.29	442 975	
TAA30SN60K1015SO	10 15/16 in.																		
TAA30SN60K1100SO	11 in.																		
TAA30SN64K300SO	300 mm	23164	300 11.81	611 24.06	400 15.75	690 27.17	730 28.74	190 7.48	830 32.68	276 10.87	90 3.54	36 1 ½	294 11.57	156 6.13	62 2.44	20 0.78	307 12.07	524 1156	
TAA30SN64K1107SO	11 7/16 in.																		
TAA30SN64K1108SO	11 1/2 in.																		
TAA30SN64K1115SO	11 15/16 in.																		
TAA30SN64K1200SO	12 in.																		
TAA30SN68K320SO	320 mm	23168	320 12.60	655 25.79	440 17.32	730 28.74	770 30.31	200 7.87	880 34.65	296 11.66	115 4.53	36 1 ½	324 12.75	176 6.92	62 2.44	33 1.29	347 13.65	634 1398	
TAA30SN68K1207SO	12 7/16 in.																		
TAA30SN68K1208SO	12 1/2 in.																		
TAA30SN72K340SO	340 mm	23172	320 12.60	665 26.18	460 18.11	730 28.74	770 30.31	200 7.87	950 37.40	296 11.66	115 4.53	36 1 ½	328 12.91	180 7.08	62 2.44	36 1.40	355 13.96	760 1676	
TAA30SN72K1215SO	12 15/16 in.																		
TAA30SN72K1300SO	13 in.																		
TAA30SN72K1307SO	13 7/16 in.																		
TAA30SN72K1308SO	13 1/2 in.																		
TAA30SN76K360SO	360 mm	23176	340 13.39	695 27.36	490 19.29	790 31.10	830 32.68	220 8.66	1000 39.37	296 11.66	95 3.74	36 1 ½	331 13.04	183 7.21	62 2.44	37 1.47	361 14.20	838 1848	
TAA30SN76K1315SO	13 15/16 in.																		
TAA30SN76K1400SO	14 in.																		
TAA30SN80K380SO	380 mm	23180	350 13.78	745 29.33	520 20.47	820 32.28	860 33.86	220 8.66	1040 40.94	316 12.45	90 3.54	36 1 ½	346 13.63	188 7.40	62 2.44	39 1.55	371 14.59	921 2031	
TAA30SN80K1415SO	14 15/16 in.																		
TAA30SN80K1500SO	15 in.																		

⁽¹⁾SN 3000 Series comes standard with double nut tapered adapter

TAASN 3100 SERIES FOUR-BOLT PILLOW BLOCK

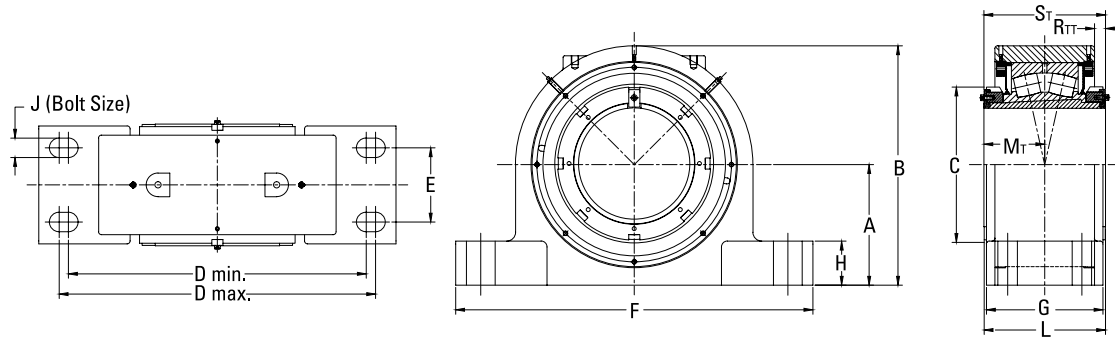

Bearing Part No. ⁽¹⁾	Shaft Dia.	Bearing No.	A	B	C	D min.	D max.	E	F	G	H	J	L	M _T	N	R _T	S _T	Wt.
			mm in.	mm in.	mm in.	mm in.	mm in.	mm in.	mm in.	mm in.	mm in.	mm in.	mm in.	mm in.	mm in.	mm in.	mm in.	mm in.
TAA31SN34K150S0	150 mm	23134	170 6.69	333 13.11	220 8.66	410 16.14	450 17.72	100 3.94	510 20.08	171.5 6.75	65 2.56	24 1	180 7.08	95 3.73	48 1.89	14 0.53	188 7.38	104 230
TAA31SN34K513S0	5 1/16 in.																	
TAA31SN34K514S0	5 7/16 in.																	
TAA31SN34K515S0	5 9/16 in.																	
TAA31SN34K600S0	6 in.	23136	180 7.09	353 13.90	230 9.06	430 16.93	470 18.50	110 4.33	530 20.87	180 7.09	70 2.76	24 1	189 7.45	99 3.90	48 1.89	14 0.57	197 7.74	122 268
TAA31SN36K160S0	160 mm																	
TAA31SN36K605S0	6 3/16 in.																	
TAA31SN36K606S0	6 3/8 in.																	
TAA31SN36K607S0	6 7/16 in.	23138	190 7.48	375 14.76	240 9.45	460 18.11	500 19.69	120 4.72	560 22.05	196.2 7.72	75 2.95	24 1	200 7.87	105 4.13	48 1.89	16 0.61	208 8.17	144 317
TAA31SN38K170S0	170 mm																	
TAA31SN38K613S0	6 9/16 in.																	
TAA31SN38K614S0	6 7/8 in.																	
TAA31SN38K615S0	6 11/16 in.	23140	210 8.27	411 16.18	250 9.84	490 19.29	530 20.87	130 5.12	610 24.02	206 8.12	80 3.15	30 1 1/4	215 8.46	110 4.32	55 2.17	16 0.64	218 8.57	182 401
TAA31SN40K180S0	180 mm																	
TAA31SN40K702S0	7 1/8 in.																	
TAA31SN40K703S0	7 3/16 in.																	
TAA31SN40K704S0	7 1/4 in.	23144	220 8.27	456 17.95	280 11.02	520 20.47	560 22.05	140 5.51	640 25.20	216.2 8.51	85 3.35	30 1 1/4	231 9.11	119 4.68	55 2.17	21 0.81	235 9.24	212 468
TAA31SN44K200S0	200 mm																	
TAA31SN44K713S0	7 9/16 in.																	
TAA31SN44K714S0	7 7/8 in.																	
TAA31SN44K715S0	7 11/16 in.	23148	240 9.45	474 18.66	300 11.81	580 22.83	620 24.41	150 5.91	700 27.56	240 9.45	90 3.54	30 1 1/4	245 9.66	125 4.93	55 2.17	22 0.88	247 9.71	265 584
TAA31SN48K220S0	220 mm																	
TAA31SN48K807S0	8 7/16 in.																	
TAA31SN48K808S0	8 1/2 in.																	
TAA31SN48K815S0	8 9/16 in.																	
TAA31SN48K900S0	9 in.																	

⁽¹⁾SN 3100 Series comes standard with double nut tapered adapter

Continued on next page.

TAASN 3100 SERIES FOUR-BOLT PILLOW BLOCK – continued

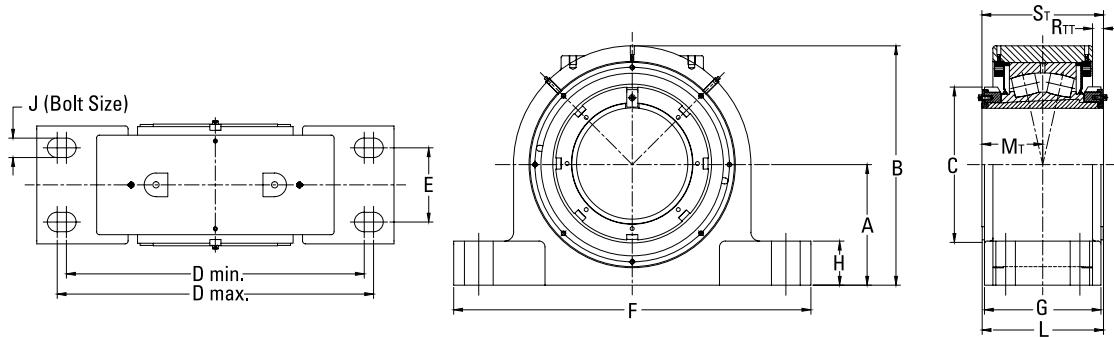

Continued from previous page.

Bearing Part No. ⁽¹⁾	Shaft Dia.	Bearing No.	A	B	C	D min.	D max.	E	F	G	H	J (Bolt Size)	L	M _T	N	R _{TT}	S _T	Wt.	
	mm in.		mm in.	mm in.	mm in.	mm in.	mm in.	mm in.	mm in.	mm in.	mm in.	mm in.	mm in.	mm in.	mm in.	mm in.	mm in.	mm in.	kg lbs.
TAA31SN52K240S0	240 mm	23152	260	530.6	330	642	682	160	770	236	95	36	265	91	62	29	275	327	
TAA31SN52K907S0	9 7/16 in.		10.24	20.89	12.99	25.28	26.85	6.30	30.31	9.30	3.74	1 1/2	10.45	5.45	2.44	1.15	10.82	721	
TAA31SN52K908S0	9 1/2 in.																		
TAA31SN56K260S0	260 mm	23156	280	551	350	650	690	160	790	236	100	36	266	139	62	20	275	403	
TAA31SN56K915S0	9 15/16 in.		11.02	21.69	13.78	25.59	27.17	6.30	31.10	9.30	3.94	1 1/2	10.46	5.46	2.44	0.80	10.83	888	
TAA31SN56K1000S0	10 in.																		
TAA31SN56K1007S0	10 7/16 in.																		
TAA31SN56K1008S0	10 1/2 in.																		
TAA31SN60K280S0	280 mm	23160	300	591	380	690	730	190	830	266	125	36	296	146	62	18	287	487	
TAA31SN60K1015S0	10 15/16 in.		11.81	23.27	14.96	27.17	28.74	7.48	32.68	10.48	4.92	1 1/2	11.63	5.73	2.44	0.71	11.29	1074	
TAA31SN60K1100S0	11 in.																		
TAA31SN64K300S0	300 mm	23164	320	631	400	730	770	200	880	276	110	36	311	156	62	20	307	573	
TAA31SN64K1107S0	11 7/16 in.		12.60	24.84	15.75	28.74	30.31	7.87	34.65	10.82	4.33	1 1/2	12.23	6.13	2.44	0.78	12.07	1263	
TAA31SN64K1108S0	11 1/2 in.																		
TAA31SN64K1115S0	11 15/16 in.																		
TAA31SN64K1200S0	12 in.																		
TAA31SN68K320S0	320 mm	23168	340	675	440	790	830	220	950	296	115	36	346	176	62	33	347	713	
TAA31SN68K1207S0	12 7/16 in.		13.39	26.57	17.32	31.10	32.68	8.66	37.40	11.66	4.53	1 1/2	13.62	6.92	2.44	1.29	13.65	1572	
TAA31SN68K1208S0	12 1/2 in.																		
TAA31SN72K340S0	340 mm	23172	350	695	460	820	860	220	1000	296	115	36	350	180	62	36	355	787	
TAA31SN72K1215S0	12 15/16 in.		13.78	27.36	18.11	32.28	33.86	8.66	39.37	11.66	4.53	1 1/2	13.77	7.08	2.44	1.41	13.96	1736	
TAA31SN72K1300S0	13 in.																		
TAA31SN72K1307S0	13 7/16 in.																		
TAA31SN72K1308S0	13 1/2 in.																		
TAA31SN76K360S0	360 mm	23176	360	715	490	850	890	220	1040	296	115	36	353	183	62	37	361	862	
TAA31SN76K1315S0	13 15/16 in.		14.17	28.15	19.29	33.46	35.04	8.66	40.94	11.66	4.53	1 1/2	13.90	7.21	2.44	1.47	14.20	1901	
TAA31SN76K1400S0	14 in.																		
TAA31SN80K380S0	380 mm	23180	380	775	520	930	970	240	1120	316	120	42	373	188	68	39	371	1088	
TAA31SN80K1415S0	14 15/16 in.		14.96	30.51	20.47	36.61	38.19	9.45	44.09	12.45	4.72	1 5/8	14.69	7.40	2.68	1.55	14.59	2398	
TAA31SN80K1500S0	15 in.																		

⁽¹⁾SN 3100 Series comes standard with double nut tapered adapter

DAAC PILOTED FLANGE CARTRIDGES

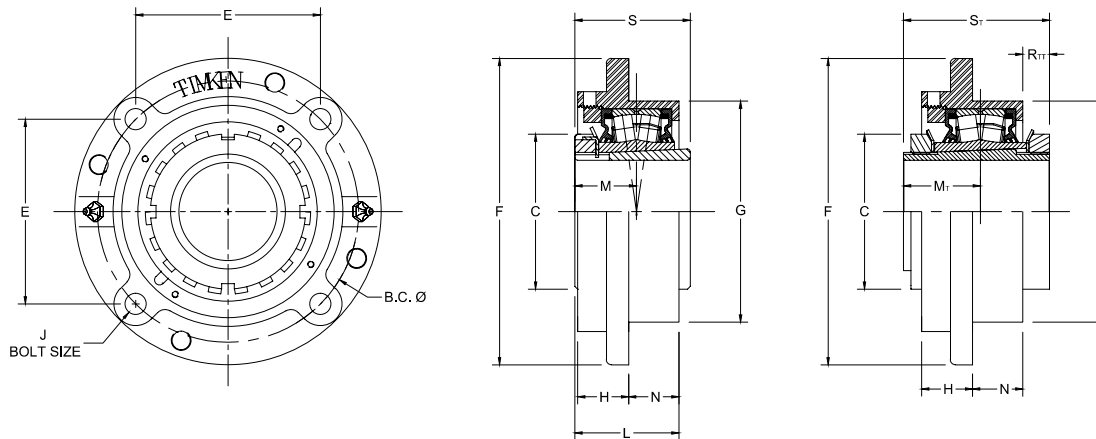

Bearing Part No. ⁽¹⁾	Shaft Dia.	Bearing No.	B.C.	C	E	F	G ⁽²⁾	H	I	J	L	M	M _T	N	R	R _T	S	S _T	Wt.
	mm in.		mm in.	mm in.	mm in.	mm in.	mm in.	mm in.	mm in.	mm in.	mm in.	mm in.	mm in.	mm in.	mm in.	mm in.	mm in.	mm in.	kg lbs.
DAAC09K107S	1 7/16 in.																		
DAAC09K108S	1 1/2 in.	22209	111.3 4.38	65.0 2.56	78.5 3.09	133.4 5.25	92.1 3.625	26.7 1.05	48.3 1.90	10 7/16	55.4 2.18	30.7 1.21	34.2 1.34	23.9 0.94	5.1 0.20	6.4 0.25	50.3 1.98	65.33 2.57	4.1 9
DAAC09K040S	40 mm																		
DAAC10K111S	1 1/16 in.																		
DAAC10K112S	1 3/4 in.	22210	130.3 5.13	70.1 2.76	91.9 3.62	155.7 6.13	107.95 4.250	26.7 1.05	58.9 2.32	10 7/16	60.1 2.37	33.5 1.32	37.6 1.48	25.4 1.00	5.1 0.20	7.1 0.28	55.1 2.17	71.33 2.81	4.5 10
DAAC10K045S	45 mm																		
DAAC11K115S	1 15/16 in.																		
DAAC11K200S	2 in.	22211	136.7 5.38	74.9 2.95	96.5 3.80	162.1 6.38	114.3 4.500	31.5 1.24	62.2 2.45	10 7/16	63.2 2.49	35.6 1.40	39.1 1.54	25.4 1.00	4.1 0.16	9.6 0.38	58.9 2.32	76.33 3.01	5.0 11
DAAC11K050S	50 mm																		
DAAC13K203S	2 3/16 in.																		
DAAC13K204S	2 1/4 in.	22213	152.4 6.00	82.6 3.35	107.7 4.24	181.1 7.13	127.0 5.000	37.3 1.47	84.8 3.34	12 1/2	65.5 2.58	39.6 1.56	43.7 1.72	25.4 1.00	-2.8 -0.11	13.2 0.52	65.0 2.56	82.83 3.26	7.3 16
DAAC13K060S	60 mm																		
DAAC15K207S	2 7/16 in.																		
DAAC15K208S	2 1/2 in.	22215	165.1 6.50	98.0 3.86	116.8 4.60	193.8 7.63	139.7 5.500	32.3 1.27	79.0 3.11	12 1/2	69.9 2.75	43.9 1.73	48.7 1.92	31.8 1.25	3.6 0.14	17.6 0.69	72.9 2.87	92.33 3.64	8.2 18
DAAC15K065S	65 mm																		
DAAC17K215S	2 15/16 in.																		
DAAC17K300S	3 in.	22217	190.5 7.50	110.0 4.33	134.6 5.30	222.3 8.75	161.9 6.375	32.5 1.28	90.2 3.55	16 3/8	79.8 3.14	49.8 1.96	50.2 1.98	35.1 1.38	2.3 0.09	24.1 0.95	82.0 3.23	104.33 4.12	11.3 25
DAAC17K075S	75 mm																		
DAAC20K307S	3 7/16 in.																		
DAAC20K308S	3 1/2 in.	22220	219.2 8.63	130.0 5.12	154.9 6.10	260.4 10.25	187.3 7.375	41.1 1.62	106.2 4.18	20 3/4	91.9 3.62	58.4 2.30	63.6 2.51	35.1 1.38	5.1 0.20	24.7 0.97	97.0 3.82	121.83 4.80	16.8 37
DAAC20K090S	90 mm																		
DAAC22K315S	3 15/16 in.																		
DAAC22K400S	4 in.	22222	238.3 9.38	145.0 5.71	168.4 6.63	276.4 10.88	206.4 8.125	48.0 1.89	116.8 4.60	20 3/4	100.1 3.94	63.0 2.48	65.8 2.59	38.1 1.50	4.6 0.18	27.8 1.09	104.9 4.13	130.7 5.15	26.3 58
DAAC22K100S	100 mm																		
DAAC26K407S ⁽³⁾	4 7/16 in.																		
DAAC26K408S ⁽³⁾	4 1/2 in.	22226	298.5 11.75 ⁽³⁾	165.1 6.50	149.4 5.88 ⁽³⁾	342.9 13.50	260.4 10.250	47.0 1.85	137.9 5.43	20 3/4 ⁽³⁾	116.8 4.60	71.9 2.83	76.6 3.01	48.3 1.90	4.1 0.16	28.2 1.11	120.9 4.76	149.65 5.89	34.5 76
DAAC26K115S ⁽³⁾	115 mm																		

⁽¹⁾Double-nut (TAA/DAA) part number shown. Single-nut (TA/DV) version available upon request.

⁽²⁾Pilot tolerance: +0/-0.05 mm (+0/-0.002 in.).

⁽³⁾Six-bolt housing.

TAAFC SQUARE PILOTED FLANGE CARTRIDGES

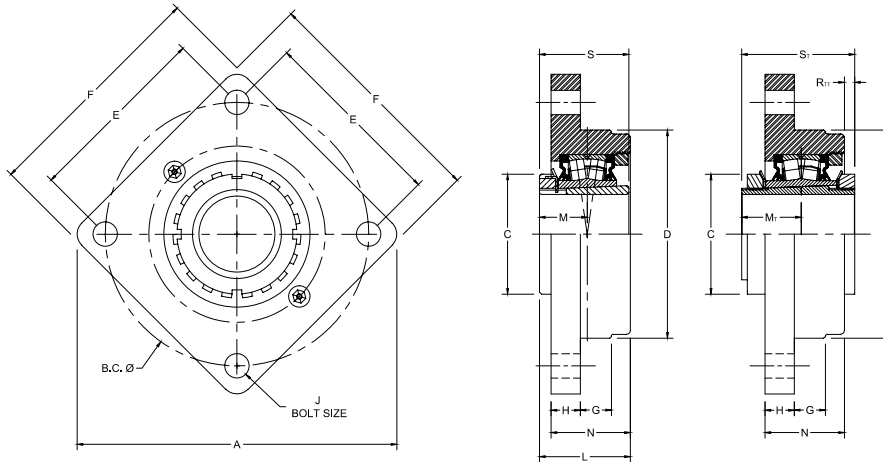

Bearing Part No. ⁽¹⁾	Shaft Dia.	Bearing No.	A	B.C.	C	D ⁽²⁾	E	F	G	H	J	L	M	M _T	N	R _T	S	S _T	Wt.	
	mm in.		mm in.	mm in.	mm in.	mm in.	mm in.	mm in.	mm in.	mm in.	mm in.	mm in.	mm in.	mm in.	mm in.	mm in.	mm in.	mm in.	mm in.	kg lbs.
TAAFC15K207S	2 7/16 in.	22215	255.0	215.1	98.0	169.9	152.4	192.0	25.4	23.9	16	79.5	43.9	48.7	64.8	8.0	72.9	92.33	11.3	
TAAFC15K208S	2 1/2 in.		10.04	8.47	3.86	6.690	6.00	7.56	1.00	0.94	5/8	3.13	1.73	1.92	2.55	0.32	2.87	3.64	25	
TAAFC15K065S	65 mm																			
TAAFC17K215S	2 15/16 in.	22217	282.4	240.0	110.0	190.0	169.7	212.1	25.4	25.4	16	88.6	49.8	50.2	69.9	15.3	82.0	104.33	13.6	
TAAFC17K300S	3 in.		11.12	9.45	4.33	7.480	6.68	8.35	1.00	1.00	5/8	3.49	1.96	1.98	2.75	0.60	3.23	4.12	30	
TAAFC17K075S	75 mm																			
TAAFC20K307S	3 7/16 in.	22220	330.2	279.9	130.0	230.1	197.9	247.9	31.8	28.7	20	105.7	58.4	63.6	94.2	10.9	97.0	121.83	18.1	
TAAFC20K308S	3 1/2 in.		13.00	11.02	5.12	9.060	7.79	9.76	1.25	1.13	3/4	4.16	2.30	2.51	3.71	0.43	3.82	4.80	40	
TAAFC20K090S	90 mm																			
TAAFC22K315S	3 15/16 in.	22222	367.0	309.9	145.0	255.0	219.2	274.3	44.5	26.4	20	113.0	63.0	65.8	101.1	14.9	104.9	130.7	27.2	
TAAFC22K400S	4 in.		14.45	12.20	5.71	10.039	8.63	10.80	1.75	1.04	3/4	4.45	2.48	2.59	3.98	0.59	4.13	5.15	60	
TAAFC22K100S	100 mm																			
TAAFC26K407S	4 7/16 in.	22226	411.5	355.1	165.1	290.0	251.0	298.5	41.9	32.0	24	130.6	71.9	76.6	114.3	14.4	120.9	149.65	42.6	
TAAFC26K408S	4 1/2 in.		16.20	13.98	6.50	11.417	9.88	11.75	1.65	1.26	7/8	5.14	2.83	3.01	4.50	0.56	4.76	5.89	94	
TAAFC26K115S	115 mm																			

⁽¹⁾Double-nut (TAA/DAA) part number shown. Single-nut (TA/DV) version available upon request.

⁽²⁾Pilot tolerance: +0/-0.05 mm (+0/-0.002 in.).

TAAFB SQUARE FLANGE BLOCKS

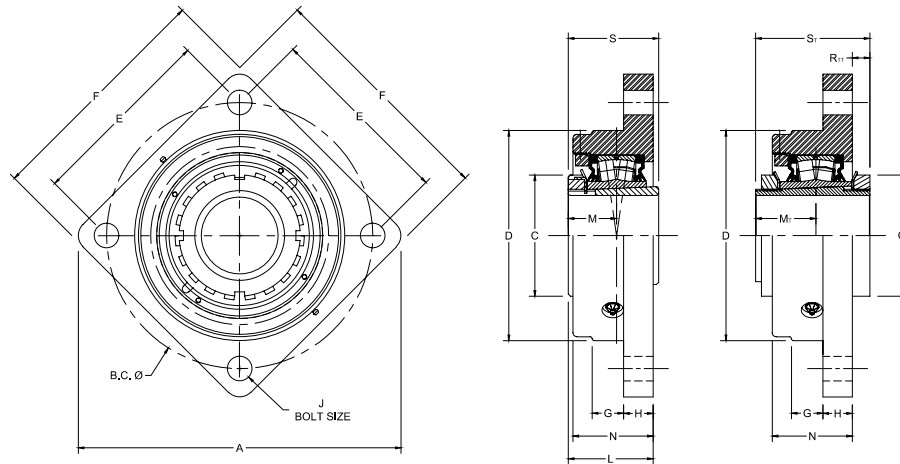

Bearing Part No. ⁽¹⁾	Shaft Dia.	Bearing No.	A	B.C.	C	D	E	F	G	H	J	L	M	M _T	N	R _{TT}	S	S _T	Wt.	
	mm in.		mm in.	mm in.	mm in.	mm in.	mm in.	mm in.	mm in.	mm in.	mm in.	mm in.	mm in.	mm in.	mm in.	mm in.	mm in.	mm in.	mm in.	kg lbs.
TAFB15K207S	2 7/16 in.	22215	255.0	215.1	98.0	169.9	152.4	192.0	25.4	23.9	16	73.7	43.9	48.7	64.8	13.8	72.9	92.33	11.3	
TAFB15K208S	2 1/2 in.		10.04	8.47	3.86	6.69	6.00	7.56	1.00	0.94	5/8	2.90	1.73	1.92	2.55	0.54	2.87	3.64	25	
TAFB15K065S	65 mm																			
TAFB17K215S	2 15/16 in.	22217	282.4	240.0	110.0	190.0	169.7	212.1	25.4	25.4	16	88.6	49.8	50.2	69.9	15.3	82.0	104.33	13.6	
TAFB17K300S	3 in.		11.12	9.45	4.33	7.48	6.68	8.35	1.00	1.00	3/8	3.49	1.96	1.98	2.75	0.60	3.23	4.12	30	
TAFB17K075S	75 mm																			
TAFB20K307S	3 7/16 in.	22220	330.2	280.0	130.0	230.1	197.9	247.9	31.8	28.7	20	105.7	58.4	63.6	94.2	10.9	97.0	121.83	18.1	
TAFB20K308S	3 1/2 in.		13.00	11.02	5.12	9.06	7.79	9.76	1.25	1.13	3/4	4.16	2.30	2.51	3.71	0.43	3.82	4.80	40	
TAFB20K090S	90 mm																			
TAFB22K315S	3 15/16 in.	22222	367.0	309.9	145.0	255.0	219.2	279.4	44.5	26.4	20	113.0	63.0	65.8	101.1	14.9	104.9	130.7	27.2	
TAFB22K400S	4 in.		14.45	12.20	5.71	10.04	8.63	11.00	1.75	1.04	3/4	4.45	2.48	2.59	3.98	0.59	4.13	5.15	60	
TAFB22K100S	100 mm																			
TAFB26K407S	4 7/16 in.	22226	411.5	354.8	165.1	290.0	251.0	298.5	41.9	32.0	24	130.6	71.9	76.6	114.3	14.4	120.9	149.65	42.6	
TAFB26K408S	4 1/2 in.		16.20	13.97	6.50	11.42	9.88	11.75	1.65	1.26	7/8	5.14	2.83	3.01	4.50	0.56	4.76	5.89	94	
TAFB26K115S	115 mm																			

⁽¹⁾Double-nut (TAA/DAA) part number shown. Single-nut (TA/DV) version available upon request.

TAFNL SERIES SQUARE FLANGE BLOCKS - TAPERED BORE EQUIVALENT

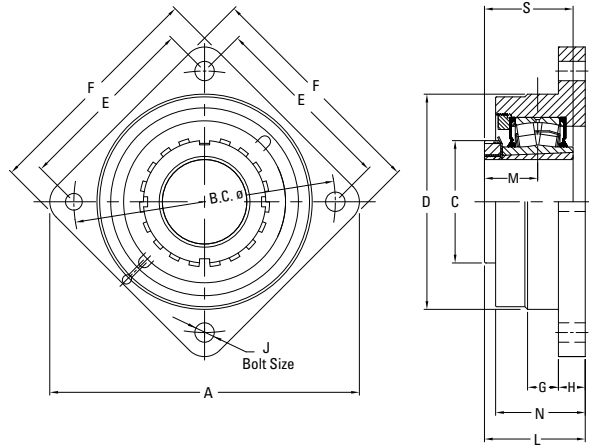

Bearing Part No.	Shaft Dia.	Bearing No.	A	B.C	C	D min.	E	F	G	H	J	L	M	N	S	Wt.
	mm in.		mm in.	mm in.	mm in.	mm in.	mm in.	mm in.	mm in.	mm in.	mm in.	mm in.	mm in.	mm in.	mm in.	kg lbs.
TAFNL15K207S	2 7/8 in.	22215	255.0	215.0	98.0	170.0	152.0	192.0	25.4	23.9	16	73.7	43.9	64.8	72.9	11.3
TAFNL15K208S	2 1/2 in.		10.04	8.47	3.86	6.69	6.00	7.56	1.00	0.94	5/8	2.90	1.73	2.55	2.87	25
TAFNL15K065S	65 mm															
TAFNL16K211S	2 11/16 in.	22216	255.0	215.0	105.0	170.0	152.0	192.0	25.4	23.9	16	76.0	47.5	64.8	78.0	11.3
TAFNL16K212S	2 3/4 in.		10.04	8.47	4.12	6.69	6.00	7.56	1.00	0.94	5/8	3.00	1.87	2.55	3.07	25
TAFNL16K070S	70 mm															
TAFNL17K215S	2 9/16 in.	22217	282.0	240.0	110.0	190.0	170.0	212.0	25.4	24.9	16	81.0	50.0	69.0	82.0	13.6
TAFNL17K300S	3 in.		11.12	9.45	4.33	7.48	6.68	8.35	1.00	0.98	5/8	3.19	1.97	2.73	3.23	30
TAFNL17K075S	75 mm															
TAFNL18K303S	3 3/8 in.	22218	282.0	240.0	119.6	190.0	170.0	212.0	25.4	25.0	16	83.0	52.1	69.9	86.1	13.6
TAFNL18K304S	3 1/4 in.		11.12	9.45	4.71	7.48	6.68	8.35	1.00	0.98	5/8	3.27	2.05	2.75	3.39	30
TAFNL18K080S	80 mm															
TAFNL20K307S	3 7/8 in.	22220	329.0	280.0	130.0	230.0	198.0	248.0	31.8	28.7	20	105.7	58.4	94.2	97.0	18.1
TAFNL20K308S	3 1/2 in.		12.97	11.02	5.12	9.06	7.79	9.76	1.25	1.13	3/4	4.16	2.30	3.71	3.82	40
TAFNL20K090S	90 mm															
TAFNL22K315S	3 5/8 in.	22222	365.0	309.9	145.0	255.0	219.0	274.0	44.5	26.4	20	113.0	63.0	101.1	104.9	27.2
TAFNL22K400S	4 in.		14.37	12.20	5.71	10.04	8.63	10.80	1.75	1.04	3/4	4.45	2.48	3.98	4.13	60
TAFNL22K100S	100 mm															

DAAF SQUARE FLANGE BLOCKS

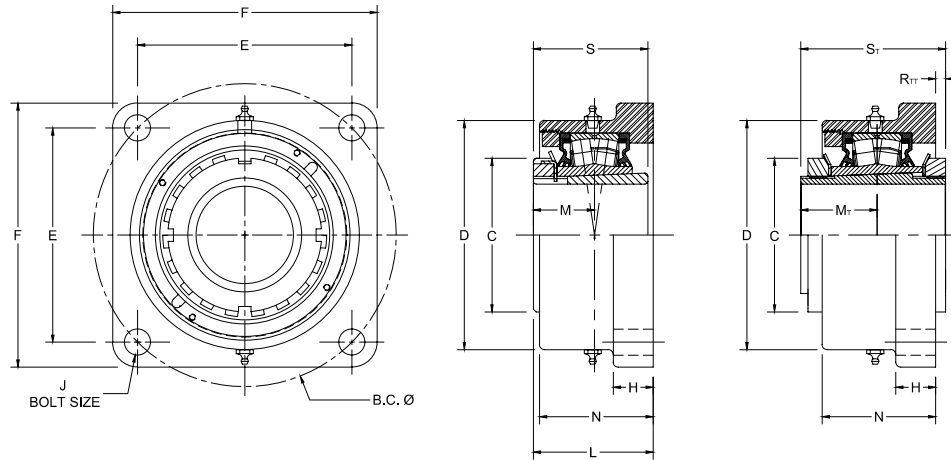

Bearing Part No. ⁽¹⁾	Shaft Dia.	Bearing No.	B.C.	C	D	E	F	H	J	L FIX	L EXP	M	M _T	N	R _{TT}	S	S _T	Wt.
	mm in.		mm in.	mm in.	mm in.	mm in.	mm in.	mm in.	mm in.	mm in.	mm in.	mm in.	mm in.	mm in.	mm in.	mm in.	mm in.	kg lbs.
DAAF09K107S	1 7/8 in.	22209	125.7 4.95	65.0 2.56	101.6 4.00	88.9 3.50	117.6 4.63	19.1 0.75	12	61.1 2.41	62.4 2.46	30.7 1.21	34.2 1.34	56.1 2.21	0.7 0.03	50.3 1.98	65.33 2.57	5.0 11
DAAF09K108S	1 1/2 in.	22209	148.3	65.0	107.8	104.9	136.7	19.1	12	61.1	62.4	30.7	34.2	56.1	0.7	50.3	65.33	5.0
DAAF09K040S	40 mm		5.84	2.56	4.25	4.13	5.38	0.75	1/2	2.41	2.46	1.21	1.34	2.21	0.03	1.98	2.57	11
DAAF10K111S	1 1/4 in.	22210	148.3 5.84	70.1 2.76	118.4 4.66	104.9 4.13	136.7 5.38	22.4 0.88	12	59.0 2.32	60.3 2.37	33.5 1.32	37.6 1.48	52.3 2.06	8.2 0.32	55.1 2.17	71.33 2.81	5.5 12
DAAF10K112S	1 3/4 in.	22210	157.2	70.1	118.4	111.3	143.0	22.4	12	59.0	60.3	33.5	37.6	52.3	8.2	55.1	71.33	5.5
DAAF10K045S	45 mm		6.19	2.76	4.66	4.38	5.63	0.88	1/2	2.32	2.37	1.32	1.48	2.06	0.32	2.17	2.81	12
DAAF11K115S	1 1/8 in.	22211	157.2	74.9	121.9	111.3	139.7	22.4	12	67.1	68.4	35.6	39.1	65.0	5.7	58.9	76.33	5.44
DAAF11K200S	2 in.		6.19	2.95	4.80	4.38	5.50	0.88	1/2	2.64	2.69	1.40	1.54	2.56	0.23	2.32	3.01	12
DAAF11K050S	50 mm																	
DAAF13K203S	2 3/8 in.	22213	175.0	85.1	137.9	124.0	157.2	25.4	16	70.8	72.9	39.6	43.7	66.8	7.9	65.0	82.83	6.8
DAAF13K204S	2 1/4 in.		6.89	3.35	5.43	4.88	6.19	1.00	5/8	2.79	2.87	1.56	1.72	2.63	0.31	2.56	3.26	15
DAAF13K060S	60 mm																	
DAAF15K207S	2 7/8 in.	22215	193.0	98.0	146.0	136.7	168.4	25.4	16	81.4	83.5	43.9	48.7	72.4	6.1	72.9	92.33	8.2
DAAF15K208S	2 1/2 in.		7.60	3.86	5.75	5.38	6.63	1.00	3/8	3.20	3.29	1.73	1.92	2.85	0.24	2.87	3.64	18
DAAF15K065S	65 mm																	
DAAF17K215S	2 15/16 in.	22217	215.4	110.0	170.7	152.4	189.0	26.9	20	87.9	90.0	49.8	50.2	77.0	16.0	82.0	104.33	12.7
DAAF17K300S	3 in.		8.48	4.33	6.72	6.00	7.44	1.06	3/4	3.46	3.54	1.96	1.98	3.03	0.63	3.23	4.12	28
DAAF17K075S	75 mm																	
DAAF20K307S	3 7/8 in.	22220	251.5	130.0	193.8	177.8	219.2	33.3	20	100.9	103.0	58.4	63.6	84.1	15.7	97.0	121.83	17.7
DAAF20K308S	3 1/2 in.		9.90	5.12	7.63	7.00	8.63	1.31	3/4	3.97	4.06	2.30	2.51	3.31	0.62	3.82	4.80	39
DAAF20K090S	90 mm																	
DAAF22K315S	3 15/16 in.	22222	278.4	145.0	215.9	196.9	253.2	38.1	24	119.9	122.0	63.0	65.8	103.1	8.0	104.9	130.7	24.0
DAAF22K400S	4 in.		10.96	5.71	8.50	7.75	9.97	1.50	7/8	4.72	4.80	2.48	2.59	4.06	0.31	4.13	5.15	53
DAAF22K100S	100 mm																	
DAAF26K407S	4 7/8 in.	22226	314.5	165.1	263.7	222.3	276.4	38.1	24	124.7	126.8	71.9	76.6	106.9	20.3	120.9	149.65	34.0
DAAF26K408S	4 1/2 in.		12.38	6.50	10.38	8.75	10.88	1.50	7/8	4.91	4.99	2.83	3.01	4.21	0.80	4.76	5.89	75
DAAF26K115S	115 mm																	

⁽¹⁾Double-nut (TAA/DAA) part number shown. Single-nut (TA/DV) version available upon request.

TAAFK 9000 SERIES SQUARE FLANGE BLOCKS

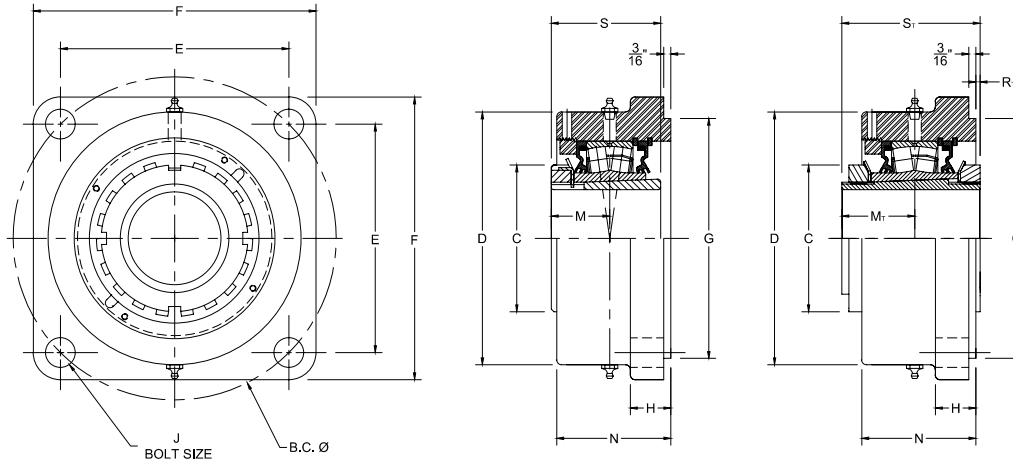

Bearing Part No. ⁽¹⁾	Shaft Dia.	Bearing No.	B.C.	C	D	E	F	G ⁽²⁾⁽³⁾⁽⁴⁾	H	J	L FIX	L EXP	M	M _T	N	R	R _T	S	S _T	Wt.
	mm in.		mm in.	mm in.	mm in.	mm in.	mm in.	mm in.	mm in.	mm in.	mm in.	mm in.	mm in.	mm in.	mm in.	mm in.	mm in.	mm in.	mm in.	kg lbs.
TAAFK11K115S	1 1/4 in.	22211	161.5 6.36	74.9 2.95	130.3 5.13	114.3 4.50	149.4 5.88	127.00 5.000	25.4 1.00	16 5/8	71.6 2.82	72.9 2.87	35.6 1.40	39.1 1.54	66.8 2.63	12.7 0.50	1.2 0.05	58.9 2.32	76.33 3.01	5.0 11
TAAFK11K200S	2 in.																			
TAAFK11K050S	50 mm																			
TAAFK13K203S	2 3/8 in.	22213	180.8 7.12	85.1 3.35	146.1 5.75	127.8 5.03	157.2 6.19	138.13 5.438	25.4 1.00	16 5/8	77.7 3.06	79.8 3.14	39.6 1.56	43.7 1.72	72.4 2.85	12.7 0.50	1.0 0.04	65.0 2.56	82.83 3.26	6. 14
TAAFK13K204S	2 1/4 in.																			
TAAFK13K060S	60 mm																			
TAAFK15K207S	2 7/8 in.	22215	215.9 8.50	98.0 3.86	168.9 6.65	152.7 6.01	189.0 7.44	160.35 6.313	26.9 1.06	20 3/4	84.8 3.34	86.9 3.42	43.9 1.73	48.7 1.92	76.2 3.00	11.9 0.47	2.7 0.11	72.9 2.87	92.33 3.64	7.7 17
TAAFK15K208S	2 1/2 in.																			
TAAFK15K065S	65 mm																			
TAAFK17K215S	2 15/16 in.	22217	241.3 9.50	110.0 4.33	193.8 7.63	170.7 6.72	212.9 8.38	187.33 7.375	33.3 1.31	20 3/4	96.3 3.79	98.3 3.87	49.8 1.96	50.2 1.98	84.1 3.31	14.2 0.56	7.6 0.30	82.0 3.23	104.33 4.12	10.4 23
TAAFK17K300S	3 in.																			
TAAFK17K075S	75 mm																			
TAAFK20K307S	3 7/8 in.	22220	298.5 11.75	130.0 5.12	215.9 8.50	211.1 8.31	268.2 10.56	225.43 8.875	38.1 1.50	24 7/8	114.6 4.51	116.6 4.59	58.4 2.30	63.6 2.51	103.1 4.06	17.5 0.69	2.0 0.08	97.0 3.82	121.83 4.80	15.9 35
TAAFK20K308S	3 1/2 in.																			
TAAFK20K090S	90 mm																			
TAAFK22K315S ⁽⁵⁾	3 15/16 in.	22222	327.2 12.88 ⁽⁵⁾	145.0 5.71	256.5 10.10	163.6 6.44 ⁽⁵⁾	384.3 15.13	263.53 10.375	38.1 1.50	24 1 ⁽⁵⁾	117.3 4.62	119.4 4.70	63.0 2.48	65.8 2.59	106.9 4.21	12.4 0.49	10.6 0.42	104.9 4.13	130.7 5.15	24.9 55
TAAFK22K400S ⁽⁵⁾	4 in.																			
TAAFK22K100S ⁽⁵⁾	100 mm																			
TAAFK26K407S ⁽⁵⁾	4 7/8 in.	22226	355.6 14.00 ⁽⁵⁾	165.1 6.50	284.2 11.19	177.8 7.00 ⁽⁵⁾	419.1 16.50	284.18 11.188	38.1 1.50	27 1 1/8 ⁽⁵⁾	147.3 5.80	149.4 5.88	71.9 2.83	76.6 3.01	135.1 5.32	26.4 1.04	-2.4 -0.09	120.9 4.76	149.65 5.89	49.0 108
TAAFK26K408S ⁽⁵⁾	4 1/2 in.																			
TAAFK26K115S ⁽⁵⁾	115 mm																			

⁽¹⁾Double-nut (TAA/DAA) part number shown. Single-nut (TA/DV) version available upon request.

⁽²⁾Pilot tolerance: +0/-0.05 mm (+0/-0.002 in.).

⁽³⁾Add (p) to the end of the housing designation in the part number to order with pilot using G dimension.

⁽⁴⁾Piloted flange blocks will be quoted (price and delivery) upon request. For optional spigot on flange side, insert the letter P as seen in the following example: QMFP**J***S.

⁽⁵⁾Six-bolt housing.

TAAMC CARTRIDGE BLOCKS

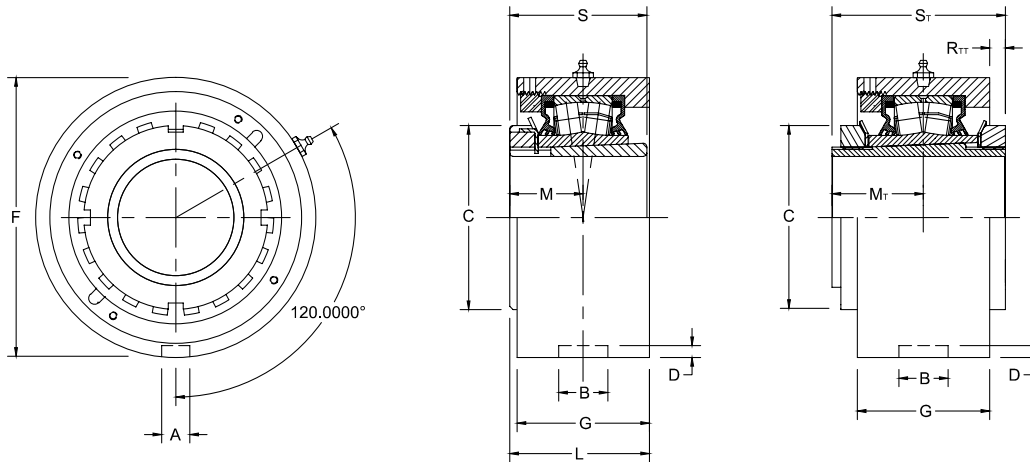

Bearing Part No. ⁽¹⁾	Shaft Dia.	Bearing No.	A	B	C	D	F	G	L FIX	L EXP	M	M _T	R _{TT}	S	S _T	Wt.
	mm in.		mm in.	mm in.	mm in.	mm in.	mm in.	mm in.	mm in.	mm in.	mm in.	mm in.	mm in.	mm in.	mm in.	kg lbs.
TAAMC11K115S	1 1/8 in.	22211	13.5 0.530	23.0 0.906	74.9 2.95	4.8 0.188	115.09 (+0/-0.05) 4.531 (+0/-0.002)	55.4 2.18	63.2 2.49	64.5 2.54	35.6 1.40	39.1 1.54	9.6 0.38	58.9 2.32	76.33 3.01	4.5 10
TAAMC11K200S	2 in.															
TAAMC11K050S	50 mm															
TAAMC13K203S	2 3/8 in.	22213	13.5 0.530	23.0 0.906	85.1 3.35	4.8 0.188	127.00 (+0/-0.05) 5.000 (+0/-0.002)	67.1 2.64	70.9 2.79	72.9 2.87	39.6 1.56	43.7 1.72	7.8 0.31	65.0 2.56	82.83 3.26	5.4 12
TAAMC13K204S	2 1/4 in.															
TAAMC13K060S	60 mm															
TAAMC15K207S	2 7/8 in.	22215	15.1 0.594	26.2 1.032	98.0 3.86	6.4 0.250	149.23 (+0/-0.05) 5.875 (+0/-0.002)	70.6 2.78	78.2 3.08	80.3 3.16	43.9 1.73	48.7 1.92	9.3 0.37	72.9 2.87	92.33 3.64	8.2 18
TAAMC15K208S	2 1/2 in.															
TAAMC15K065S	65 mm															
TAAMC17K215S	2 11/16 in.	22217	15.1 0.594	27.5 1.083	110.0 4.33	7.1 0.281	171.45 (+0/-0.05) 6.750 (+0/-0.002)	74.9 2.95	87.4 3.44	89.4 3.52	49.8 1.96	50.2 1.98	16.5 0.65	82.0 3.23	104.33 4.12	11.8 26
TAAMC17K300S	3 in.															
TAAMC17K075S	75 mm															
TAAMC20K307S	3 7/8 in.	22220	19.8 0.781	32.5 1.281	130.0 5.12	8.0 0.313	206.38 (+0/-0.05) 8.125 (+0/-0.002)	85.6 3.37	101.3 3.99	103.4 4.07	58.4 2.30	63.6 2.51	15.3 0.60	97.0 3.82	121.83 4.80	14.5 32
TAAMC20K308S	3 1/2 in.															
TAAMC20K090S	90 mm															
TAAMC22K315S	3 11/16 in.	22222	19.8 0.781	32.5 1.281	145.0 5.71	8.0 0.313	222.25 (+0/-0.08) 8.750 (+0/-0.003)	97.8 3.85	112.0 4.41	114.0 4.49	63.0 2.48	65.8 2.59	15.9 0.63	104.9 4.13	130.7 5.15	18.1 40
TAAMC22K400S	4 in.															
TAAMC22K100S	100 mm															
TAAMC26K407S	4 7/8 in.	22226	19.8 0.780	38.1 1.500	165.1 6.50	8.0 0.313	265.10 (+0/-0.08) 10.437 (+0/-0.003)	104.4 4.11	124.2 4.89	126.2 4.97	71.9 2.83	76.6 3.01	20.8 0.82	120.9 4.76	149.65 5.89	23.6 52
TAAMC26K408S	4 1/2 in.															
TAAMC26K115S	115 mm															

⁽¹⁾Double-nut (TAA/DAA) part number shown. Single-nut (TA/DV) version available upon request.

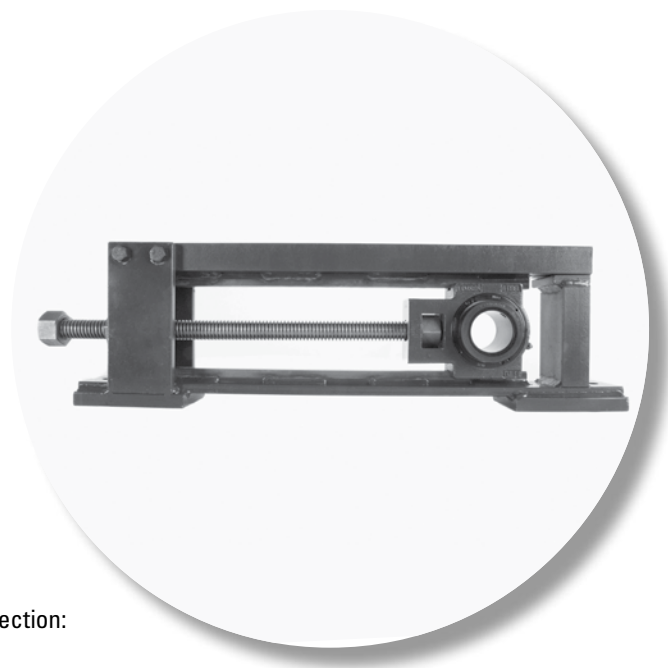

TAKE-UP FRAMES

The following topics are covered within this section:

QMTF Take-Up Frames ⁽¹⁾	210
QMT Pillow Block Take-Up Frames ⁽¹⁾	211

QMTF TAKE-UP FRAMES⁽¹⁾

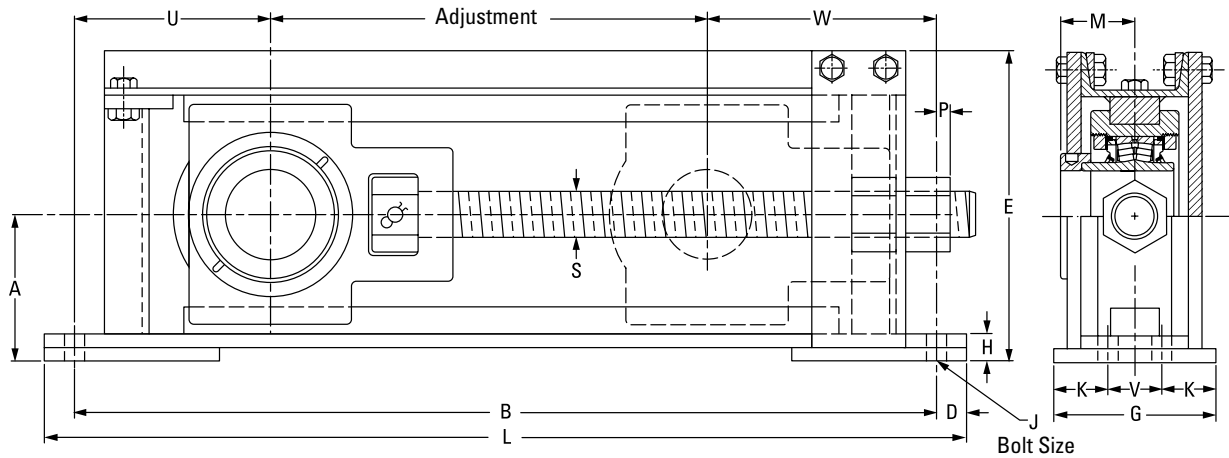

Frame Part No.	Travel Nom.	Travel Adj.	A	B	D	E	G	H	J	K	L	M	P	S	U	V	W	No. of Bolts Req.	Wt.
		mm in.	mm in.	mm in.	mm in.	mm in.	mm in.	mm in.	mm in.	mm in.	mm in.	mm in.	mm in.	mm in.	mm in.	mm in.	mm in.		kg lbs.
QMTF12-115	12	419.1 16.50	100.1 3.94	698.5 27.50	25.4 1.00	210.3 8.28	101.6 4.00	31.8 1.25	16 5/8	-	749.3 29.50	47.8 1.88	31.8 1.25	1-5 ACME	136.7 5.38	-	143.0 5.63	2	27.2 60
QMTF12-203	12	431.8 17.00	106.4 4.19	698.5 27.50	25.4 1.00	220.0 8.66	101.6 4.00	35.1 1.38	16 5/8	-	749.3 29.50	50.8 2.00	41.4 1.63	1.125-5 ACME	115.8 4.56	-	150.9 5.94	2	29.5 65
QMTF12-207	12	421.6 16.60	111.3 4.38	723.9 28.50	25.4 1.00	233.4 9.19	101.6 4.00	28.7 1.13	20 3/4	-	774.7 30.50	54.1 2.13	44.5 1.75	1.25-5 ACME	134.9 5.31	-	166.6 6.56	2	32.2 71
QMTF12-215	12	393.7 15.50	129.3 5.09	774.7 30.50	25.4 1.00	272.8 10.74	127.0 5.00	28.7 1.13	16 5/8	38.1 1.50	825.5 32.50	60.5 2.38	12.7 0.50	1.5-4 ACME	165.1 6.50	50.8 2.00	215.9 8.50	4	49.4 109
QMTF12-307	12	393.7 15.50	143.0 5.63	812.8 32.00	28.7 1.13	295.4 11.63	127.0 5.00	26.2 1.03	20 3/4	38.1 1.50	870.0 34.25	65.5 2.58	25.4 1.00	1.75-4 ACME	185.7 7.31	50.8 2.00	233.4 9.19	4	62.6 138
QMTF12-315	12	457.2 18.00	177.8 7.00	914.4 36.00	31.8 1.25	367.5 14.47	152.4 6.00	36.6 1.44	20 3/4	44.5 1.75	977.9 38.50	75.2 2.96	41.4 1.63	2-4 ACME	190.5 7.50	63.5 2.50	265.2 10.44	4	86.6 191
QMTF18-207	18	574.0 22.60	111.3 4.38	876.3 34.50	25.4 1.00	234.2 9.22	101.6 4.00	26.9 1.06	20 3/4	-	927.1 36.50	54.1 2.13	44.5 1.75	1.25-5 ACME	139.7 5.50	-	162.6 6.40	2	36.7 81
QMTF18-215	18	546.1 21.50	129.3 5.09	927.1 36.50	25.4 1.00	272.8 10.74	127.0 5.00	28.7 1.13	16 5/8	38.1 1.50	977.9 38.50	60.5 2.38	12.7 0.50	1.5-4 ACME	165.1 6.50	50.8 2.00	215.9 8.50	4	54.4 120
QMTF18-307	18	546.1 21.50	143.0 5.63	965.2 38.00	28.7 1.13	295.4 11.63	127.0 5.00	26.2 1.03	20 3/4	38.1 1.50	1022.4 40.25	65.5 2.58	25.4 1.00	1.75-4 ACME	185.7 7.31	50.8 2.00	233.4 9.19	4	70.8 156
QMTF18-315	18	609.6 24.00	177.8 7.00	1066.8 42.00	31.8 1.25	366.8 14.44	152.4 6.00	36.6 1.44	20 3/4	44.5 1.75	1130.3 44.50	75.2 2.96	41.4 1.63	2-4 ACME	190.5 7.50	63.5 2.50	265.2 10.44	4	101.2 223
QMTF24-207	24	726.4 28.60	111.3 4.38	1028.7 40.50	25.4 1.00	233.4 9.19	101.6 4.00	28.7 1.13	20 3/4	-	1079.5 42.50	54.1 2.13	44.5 1.75	1.25-5 ACME	115.8 4.56	-	166.6 6.56	2	41.3 91
QMTF24-215	24	698.5 27.50	129.3 5.09	1079.5 42.50	25.4 1.00	271.5 10.69	127.0 5.00	24.6 0.97	16 5/8	38.1 1.50	1130.3 44.50	60.5 2.38	12.7 0.50	1.5-4 ACME	165.1 6.50	50.8 2.00	215.9 8.50	4	64.0 141
QMTF24-307	24	698.5 27.50	143.0 5.63	1117.6 44.00	28.7 1.13	295.4 11.63	127.0 5.00	26.2 1.03	20 3/4	38.1 1.50	1174.8 46.25	65.5 2.58	25.4 1.00	1.75-4 ACME	185.7 7.31	50.8 2.00	233.4 9.19	4	81.2 179
QMTF24-315	24	762.0 30.00	177.8 7.00	1219.2 48.00	31.8 1.25	367.5 14.47	152.4 6.00	36.6 1.44	20 3/4	44.5 1.75	1282.7 50.50	75.2 2.96	41.4 1.63	2-4 ACME	190.5 7.50	63.5 2.50	265.2 10.44	4	112.9 249

⁽¹⁾Frame only. Bearing unit must be ordered separately. See pages 116 (V-Lock), 143-146 (CL) and 172-173 (EC) for information on take-up bearing units.
NOTE: All take-up frames come with Acme threaded rod.

QMT PILLOW BLOCK TAKE-UP FRAMES⁽¹⁾

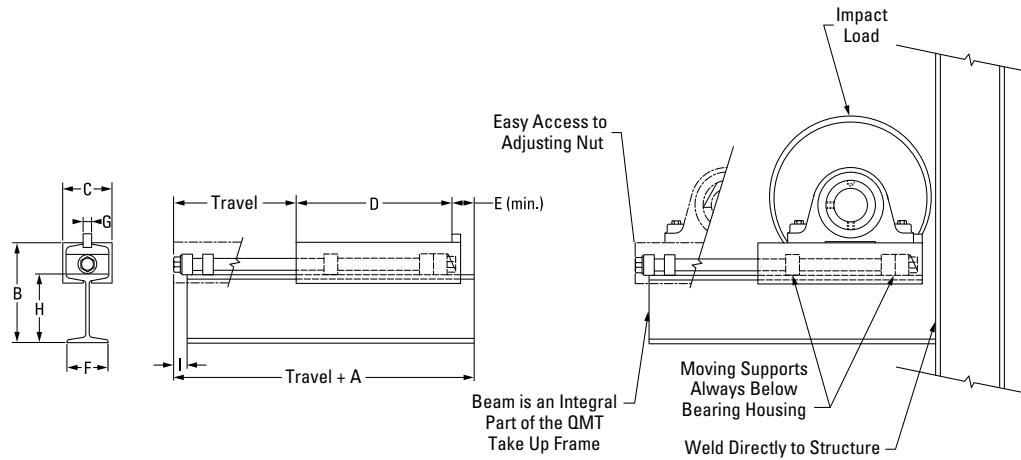

Frame Part No.	Bearing Size	Travel	A	B	C	D	E	F	G	H	I	Wt.
			mm in.	mm in.	mm in.	mm in.	mm in.	mm in.	mm in.	mm in.	mm in.	kg lbs.
QMT1 X 9	1 7/16 in. – 2 15/16 in.	9	330.2 13.0	187.3 7.375	92.1 3.625	289.1 11.38	41.4 1.63	76.2 3.00	20 3/4	127.0 5.0	25.4 1.0	11.8 26
QMT1 X 12	1 7/16 in. – 2 15/16 in.	12	330.2 13.0	187.3 7.375	92.1 3.625	289.1 11.38	41.4 1.63	76.2 3.00	20 3/4	127.0 5.0	25.4 1.0	13.6 30
QMT1 X 18	1 7/16 in. – 2 15/16 in.	18	330.2 13.0	187.3 7.375	92.1 3.625	289.1 11.38	41.4 1.63	76.2 3.00	20 3/4	127.0 5.0	25.4 1.0	16.3 36
QMT1 X 24	1 7/16 in. – 2 15/16 in.	24	330.2 13.0	187.3 7.375	92.1 3.625	289.1 11.38	41.4 1.63	76.2 3.00	20 3/4	127.0 5.0	25.4 1.0	19.1 42
QMT2 X 18	2 15/16 in. – 4 7/16 in.	18	482.6 19.0	311.2 12.25	125.4 4.938	431.8 17.00	50.8 2.00	106.4 4.19	24 1	203.2 8.0	38.1 1.5	33.6 74
QMT2 X 24	2 15/16 in. – 4 7/16 in.	24	482.6 19.0	311.2 12.25	125.4 4.938	431.8 17.00	50.8 2.00	106.4 4.19	24 1	203.2 8.0	38.1 1.5	40.8 90
QMT2 X 36	2 15/16 in. – 4 7/16 in.	36	482.6 19.0	311.2 12.25	125.4 4.938	431.8 17.00	50.8 2.00	106.4 4.19	24 1	203.2 8.0	38.1 1.5	43.6 96

⁽¹⁾Frame only. Bearing unit must be ordered separately. See pages 116 (V-Lock), 143-146 (CL) and 172-173 (EC) for information on take-up bearing units.
NOTE: All take-up frames come with Acme threaded rod.

INDEX

SPHERICAL ROLLER BEARING SOLID-BLOCK HOUSED UNIT

DAAC Piloted Flange Cartridges	201	QMSN SN-Style Two-Bolt Pillow Blocks –	
DAAF Square Flange Blocks	205	Pure Metric Design	159
DAAP Two-Bolt Pillow Blocks	177	QMT Pillow Block Take-Up Frames	211
DAAPF Four-Bolt Pillow Blocks	183	QMTF Take-Up Frames	210
Engineering	9	QMTTP Top Pull Take-Up Blocks	173
QAAF 5000 Series Flange Blocks	138	QMTU Take-Up Blocks	172
QAAPX 5000 Series Four-Bolt Pillow Blocks	129	QVC and QVVC Piloted Flange Cartridges –	
QAAPXT 5000 Series Two-Bolt Pillow Blocks	125	Straight Bore Equivalent	113
QAC and QAAC Piloted Flange Cartridges	130	QVCW and QVVCW Piloted Flange Cartridges –	
QACW and QAACW Piloted Flange Cartridges	132	Straight Bore Equivalent	114
QAF and QAAF Square Flange Blocks	134	QVF and QVVF Square Flange Blocks –	
QAF 5000 Series Round Flange Blocks	136	Straight Bore Equivalent	105
QAFY and QAAFY Round Flange Blocks	139	QVFB and QVFB Flange Blocks – Tapered Adapter Equivalent ..	106
QAMC and QAAMC Cartridge Blocks	141	QVFC and QVFC Piloted Flange Cartridges –	
QAMH and QAAMH Hanger Blocks	147	Tapered Adapter Equivalent	107
QAP and QAAP Stainless Steel Two-Bolt Pillow Blocks	119	QVFK and QVFK 9000 Series Square Flange Blocks –	
QAPF and QAAPF Four-Bolt Pillow Blocks	126	Tapered Bore Equivalent	110
QAPL and QAAPL Two-Bolt Pillow Blocks	121	QVFL and QVFL Square Flange Blocks –	
QAPR and QAAPR Four-Bolt Pillow Blocks	128	Straight Bore Equivalent	108
QASN and QAASN SN-Style Two-Bolt Pillow Blocks –		QVFN 5000 Series Square Flange Blocks –	
Pure Metric Design	123	Straight Bore Equivalent	111
QATP and QAATP Top Pull Take-Up Blocks	145	QVFX and QVFX 5000 Series Square Flange Blocks –	
QATU and QAATU Take-Up Blocks	143	Straight Bore Equivalent	109
QMC Piloted Flange Cartridges	161	QVFX and QVFX Round Flange Blocks –	
QMCW Piloted Flange Cartridges	162	Straight Bore Equivalent	112
QMF Four-Bolt Square Flange Blocks	164	QVMC and QVMC Cartridge Blocks –	
QMFL Four-Bolt Square Flange Blocks	165	Tapered Bore Equivalent	115
QMF 5000 Series Square Flange Blocks	168	QVVP Two-Bolt Pillow Blocks – Straight Bore Equivalent	92
QMFY Round Flange Blocks	166	QVVP SAF Two-Bolt Pillow Blocks –	
QMMC Cartridge Blocks	170	Tapered Bore Equivalent	94
QMMH Hanger Blocks	174	QVVPF Four-Bolt Pillow Blocks – Straight Bore Equivalent	98
QMP Two-Bolt Pillow Blocks	151	QVVP 5000 Series Four-Bolt Pillow Blocks	
QMPF Four-Bolt Pillow Blocks	153	Tapered Bore Equivalent	102
QMPH/QMPG Four-Bolt Pillow Blocks	155	QVVP SAF-Style Four-Bolt Pillow Blocks –	
QMPL Two-Bolt Pillow Blocks	152	Tapered Bore Equivalent	103
QMPR Four-Bolt Pillow Blocks	154	QVVPK 9000 Series Four-Bolt Pillow Blocks –	
QMPX 5000 Series Four-Bolt Pillow Blocks	156	Tapered Bore Equivalent	104
QMPXT 5000 Series Two-Bolt Pillow Blocks	158	QVVPKT 9000 Series Two-Bolt Pillow Blocks –	
		Tapered Bore Equivalent	97
		QVVP 5000 Series Two-Bolt Pillow Blocks – Straight Bore Equivalent	93

QVVPN SN-Style Two-Bolt Pillow Blocks – Tapered Bore Equivalent	95
QVVPR Four-Bolt Pillow Blocks – Straight Bore Equivalent.	99
QVVPX 5000 Series Four-Bolt Pillow Blocks – Straight Bore Equivalent.	100
QVVPXT 5000 Series Two-Bolt Pillow Blocks – Straight Bore Equivalent.	101
QVVSN SN-Style Two-Bolt Pillow Blocks – Pure Metric Design	96
QVVTU Take-Up Blocks – Straight Bore Equivalent.	116
Seal and Cover Options.	17
Spherical Roller Bearing Solid-Block Housed Unit Product Data Tables	89
TAAADI DI-Style Two-Bolt Pillow Block	181
TAA4DI DI-Style Four-Bolt Pillow Block	187
TAA4SD Special Duty-Style Four-Bolt Pillow Block.	185
TAAPH SAF 500 Style Four-Bolt Pillow Blocks.	190
TAAPH0 SAF 230-Style Four-Bolt Pillow Blocks	193
TAAPH0 SDAF 230-Style Four-Bolt Pillow Blocks	194
TAAPH1 SDAF 231-Style Four-Bolt Pillow Blocks	195
TAAPH6 SAF 600-Style Four-Bolt Pillow Blocks	191
TAAPH6D SDAF 600-Style Four-Bolt Pillow Blocks	192
TAAASD Special Duty-Style Two-Bolt Pillow Blocks	180
TAAASN 3000 Series Four-Bolt Pillow Block	197
TAAASN 3100 Series Four-Bolt Pillow Block	199
TAAAFB Square Flange Blocks	203
TAAFC Square Piloted Flange Cartridges	202
TAAFK 9000 Series Square Flange Blocks.	206
TAFNL Series Square Flange Blocks – Tapered Bore Equivalent	204
Take-Up Frames	209
TAAMC Cartridge Blocks	207
TAAPA SAF-Style Two-Bolt Pillow Blocks.	178
TAAPG SN-Style Four-Bolt Pillow Blocks	196
TAAPH SAF-Style Four-Bolt Pillow Blocks.	188
TAAPK 9000 Series Four-Bolt Pillow Blocks	184
TAAPKT 9000 Series Two-Bolt Pillow Blocks	182
TAAPN SN-Style Two-Bolt Pillow Blocks	179



To view more Timken catalogs, go to www.timken.com/catalogs for interactive versions, or to download the Timken catalog app for your smartphone or mobile device scan the QR code or go to timkencatalogs.squawqr.com.

TIMKEN

The Timken team applies their know-how to improve the reliability and performance of machinery in diverse markets worldwide. The company designs, makes and markets bearings, gear drives, automated lubrication systems, belts, brakes, clutches, chain, couplings, linear motion products and related power transmission rebuild and repair services.

Price: USD \$75

Stronger. By Design.

www.timken.com